

# Cam Followers

Unmounted bearing assembly consisting of hardened precision ground inner and outer raceways with either full complement or separated (cage) needle, ball, tapered or cylindrical rolling elements constructed with an integral stud or precision ground bore. Cam follower bearings provide an antifriction solution for translating rotation to linear motion or supporting either pure radial or combination thrust loads depending on the rolling elements types.

## **Bearing Configurations**

Cylindrical, Crowned, V-Groove Or Flanged

## **Mounting Styles**

Eccentric Or Concentric Stud Or Yoke













## **Outer Roller Diameter Range**

1/2" To 10" And 13 mm To 90 mm

## **Materials**

Bearing Quality Steel, Stainless

## Cam Follower Selection Guide

			SIZE RANGE		
		Product Series	Material / Finish	Inch	Metric
CAMROL		CF	Black Oxide Finish Bearing Steel	1/2 - 10	
		CYR		3/4 - 10	
		CFH		1/2 - 7	
		BCF		1/2 - 4	
		BCYR		3/4 - 4	
		MCF			16 - 90
		MCFR			13 - 90
		MCYR			5 - 50
		MCYRR			5 - 50
Heavy-Duty		CFD	Black Oxide Finish Bearing Steel	1 1/4 - 6	
		CYRD		1 1/4 - 6	
		MCFD			35 - 80
		MCYRD			15 - 50

\* For estimating purpose only, individually sizes may vary and are subject to change without notification

McGill CAMROL Cam Followers are available in 400 series stainless steel components for improved resistance to both external and internal corrosion.

CRES CAMROL bearings are dimensionally interchangeable with standard CAMROL<sup>®</sup> bearings and easily identifiable with "CR" designation.



# Inch Cam Follower Bearings **MCGILL**<sup>®</sup>



DESIGN CHARACTERISTICS					FEATURES							Page No.
Radial Load	Thrust Load	Precision	High Speed	Relative Base Cost *	Crowned OD	Eccentric Stud	Lubrication Holes	Seal	Hex Hole	Slotted Face	Jam Nuts	Page No.
●	○	●	◐	\$	○	○	S	○	○	S	-	B-15
●	○	●	◐	\$	○	-	S	○	-	-	-	B-39
●	○	●	◐	\$\$	○	-	S	○	○	S	-	B-15
◐	○	◐	◐	\$	○	○	S	○	○	S	-	B-45
◐	○	◐	◐	\$	○	-	S	○	-	-	-	B-57
●	○	●	◐	\$	S	○	S	○	○	S	S	B-69
◐	○	●	◐	\$	S	○	S	○	○	S	S	B-69
●	○	●	◐	\$	S	-	S	○	○	-	S	B-91
●	○	●	◐	\$	S	-	S	○	-	-	S	B-91
●	◐	●	◐	\$\$	○	○	○	S	S	-	-	B-103
●	◐	●	◐	\$\$	○	-	○	S	-	-	-	B-107
●	◐	●	◐	\$\$	S	○	S	-	○	S	S	B-111
●	◐	●	◐	\$\$	S	-	S	-	-	-	-	B-115

Circular Track / Misalignment  
 Load Sharing / Adjustment To Track  
 Relubrication To Help Promote Bearing Operating Life  
 Contamination Barrier  
 Blind Hole Mounting  
 Allows The Use Of A Lube Fitting When Lubrication From The Flange Side Of Bearing  
 Accessories Included

**O = Optional**  
**S = Standard**  
**○ = Not Recommended**  
 ◐ ◑ ◒ ◓ ◔  
**Poor** ← → **Best**

## Cam Follower Selection Guide

			SIZE RANGE		
		Product Series	Material / Finish	Inch	Metric
Special Duty		SDCF	Black Oxide Finish Bearing Steel	1 - 4	
		SDMCF		25 - 100	
TRAKROL		PCF	Black Oxide Finish Bearing Steel	1 1/2 - 9	
		PCYR		3 - 6	
		FCF		1 1/2 - 9	
		FCYR		3 - 6	
		VCF		2 1/2 - 8 1/2	
		VCYR		3 1/2 - 7 1/2	

McGill CAMROL Cam Followers are available in 400 series stainless steel components for improved resistance to both external and internal corrosion.

CRES CAMROL bearings are dimensionally interchangeable with standard CAMROL® bearings and easily identifiable with "CR" designation.



DESIGN CHARACTERISTICS					FEATURES							Page No.
Radial Load	Thrust Load	Precision	High Speed	Relative Base Cost *	Crowned OD	Eccentric Stud	Lubrication Hole	Seal	Hex Hole	Slotted Face	Jam Nuts	
				\$\$\$	O	O	-	S	S	-	S	B-123
				\$\$\$	O	O	-	S	S	-	S	B-125
				\$\$	O	O	-	S	-	-	O	B-131
				\$\$	O	-	-	S	S	-	-	B-133
				\$\$\$	-	O	-	S	S	-	O	B-135
				\$\$	-	-	-	S	-	-	-	B-137
				\$\$	-	O	-	S	S	-	O	B-139
				\$\$	-	-	-	S	-	-	-	B-141

Circular Track / Misalignment												
Load Sharing / Adjustment To Track												
Relubrication And Promote Bearing Life												
Contamination Barrier												
Blind Hole Mounting												
Allows The Use Of A Lube Fitting When Lubrication From The Flange Side Of Bearing												
Accessories Included												

**O = Optional**  
**S = Standard**  
**○ = Not Recommended**  
  
**Poor ← → Best**

\* For estimating purpose only, individual costs may vary and are subject to change without notification

## McGill Inch Cam Followers

McGill CAMROL bearings are full complement needle bearings feature black oxide treated bearing steel, available in two basic mounting styles for use in mechanical automation or linear motion applications. Our basic features each contribute to improved performance, while the LUBRI-DISC® seal option helps prevent metal to metal contact within the bearing while providing a barrier for contaminant entry and allow venting of excess or old grease during relubrication. In addition to the seal option these bearings are available with several dimensional choices and combinations to provide a specific solution for the application. Within the following section you can learn more about these features and how they can be applied to your application.

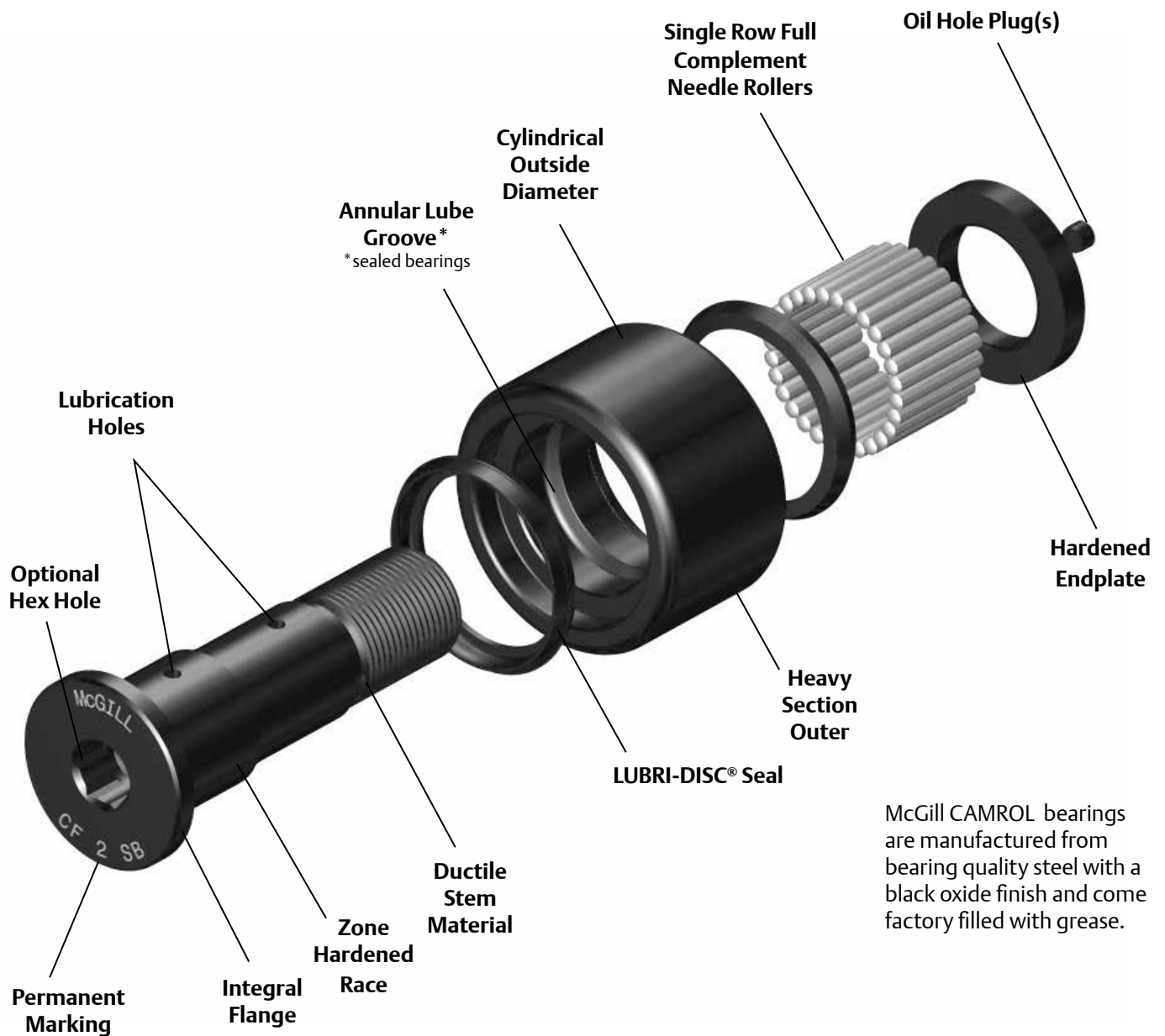

McGill CAMROL bearings are manufactured from bearing quality steel with a black oxide finish and come factory filled with grease.

# Cam Follower Inch Nomenclature

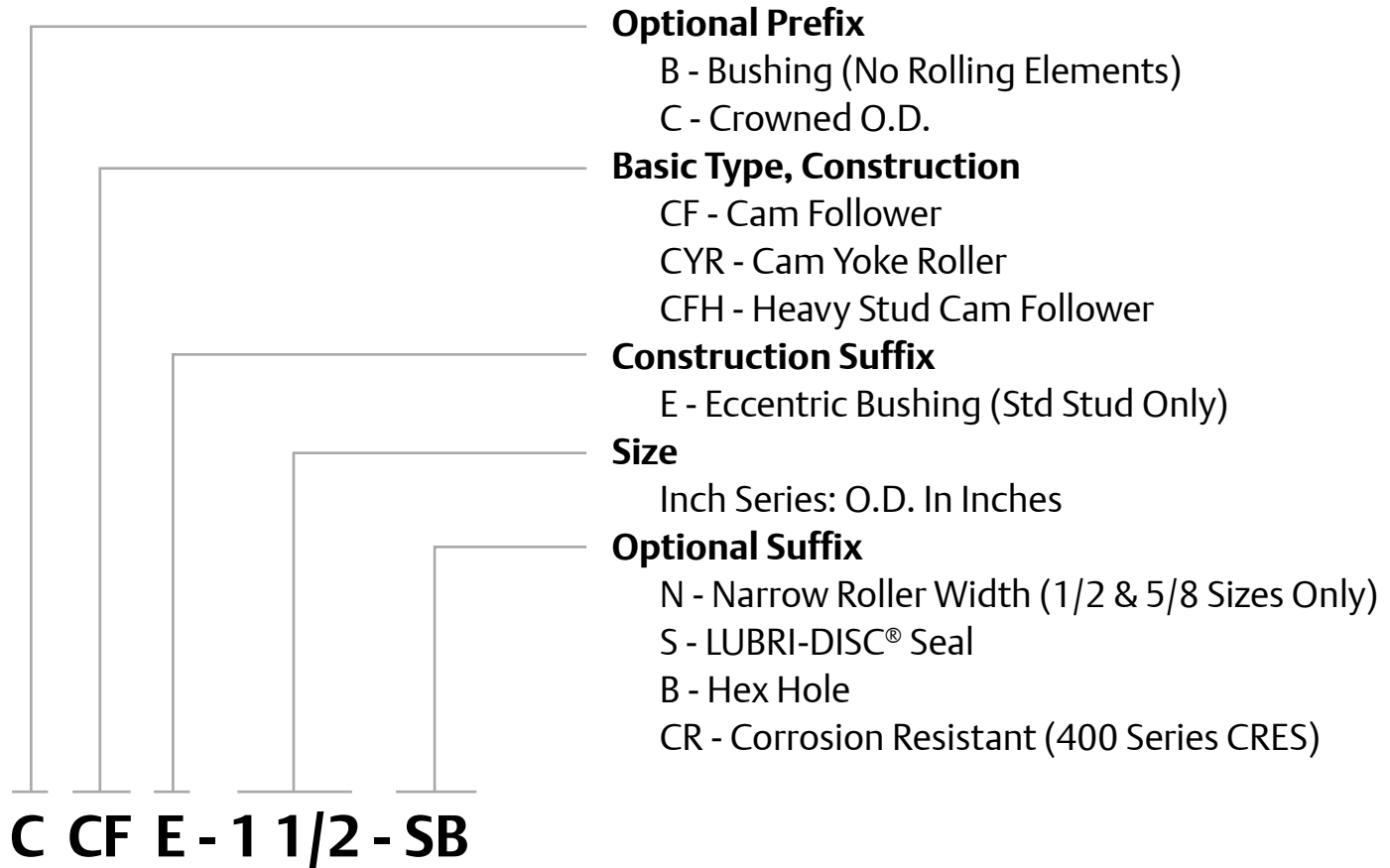



## Features and Benefits

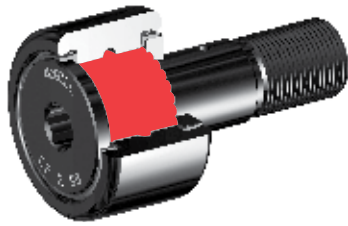

### Single Row Full Complement Needle Rollers

The needle roller diameter, length, and number have been optimized to provide a high dynamic and static load rating, contained within industry standard bearing envelope dimensions.

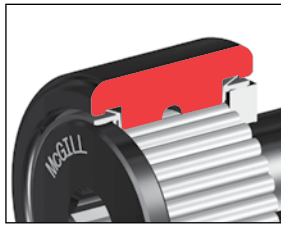

### Heavy Section Outer

The heavy section outer helps support radial loading and provide proper rolling element support.



### Cylindrical Outside Diameter (OD)

The cylindrical OD can improve performance in certain applications such as improved track capacity by maximizing the contact area with the track.



### Zone Hardened Raceways

Heat treatment used to precisely harden working surfaces of the raceway and flange. The hardened surfaces provide support for the rolling element contact stresses, while keeping the core of the inner ductile to help absorb shock loads.

## Features and Benefits continued

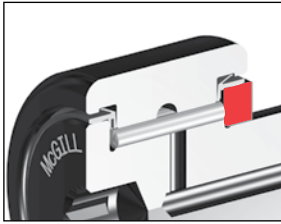

### Hardened Endplate

Similar to the flange, the endplate must provide a seal surface for the LUBRI-DISC seal and resist wear from incidental contact with the outer or rollers. The hardened and ground endplate provides a sealing surface with LUBRI-DISC<sup>®</sup> seal option.

### Factory Grease Fill

The cam follower and cam yoke roller bearings are factory lubricated with a medium temperature grease. Contact Application Engineering when application conditions require special lubricants.

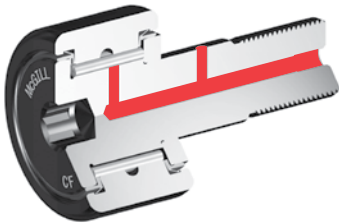

### Lubrication Holes

Depending on mounting option, McGill stud type CAMROL bearings may include a lubrication hole to accept a standard drive fitting or an included oil hole plug. The oil hole plug is recommended for closing unused holes to help protect against bearing contamination or lubrication loss.



### Yoke Roller Lubrication Hole with Annular groove

McGill CAMROL Yoke roller bearings include a lubrication hole to provide a passage for lubrication to the rolling elements from the yoke roller bore. The customer supplied shaft must provide axial lubrication path to supply bearing. An annular groove in the inner ring bore helps direct lubricant to the hole, making alignment of the shaft and the inner ring holes less critical.



### Oil Hole Plug (s)

All McGill stud type Cam followers include 1-2 (depending on # of holes) oil hole plugs to help provide proper lubrication path to the rolling elements and prevent contamination from entering the bearing through an unused oil hole.

## Options



### Black Oxide Finish

Bearings have a black oxide finish on all external surfaces.



### LUBRI-DISC® Seal

The CAMROL standard for seals, the LUBRI-DISC seal helps keep contaminants out and lubrication in the bearing, with an integral back plate to separate the metal to metal contact between the outer ring and endplate(s) or flange. The back plate feature reduces friction resulting in lower operating temperatures which can extend grease life and allowing for higher operating speeds. The seal also includes vents to help prevent seal blowout during relubrication, while the outer raceway is machined with a reservoir for additional lubricant capacity. The LUBRI-DISC seal option has a good balance of sealing, lubricant capacity, and low drag operation essential to a precision cam follower suited for most industrial applications.

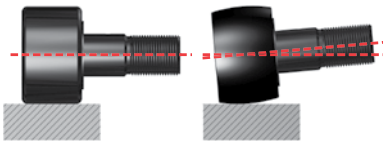

### Crowned Outside Diameter (OD)

A crown on the OD of a cam follower bearing can increase bearing life versus a standard cylindrical cam follower. The crown achieves this performance by helping to distribute the stress on the outer ring and rolling elements resulting from misalignment due to mounting inaccuracy or stud deflection. The crown also helps reduce outer skidding in turntable or rotary applications. Not all applications may see the benefit of a crowned OD, consult Application Engineering for guidance for your application.



### Heavy Stud Diameter

The increase stem diameter of heavy stud cam followers increases static load capacity of the bearing due to the larger stud diameter. The increase in diameter reduces the amount of deflection that can occur when cam followers are radial loaded. The resultant increase allows a maximum recommended loading of 50% BDR.

\*On Heavy-Stud Type Bearings, CFH inch series only

## Options continued



### Hex Hole (Broached)

The hex hole can aid in the installation and removal of stud type cam followers by increasing the holding power over a standard screw driver slot. The hex feature is identified with a "B" since it is produced using a broach process. Bearing relubrication from flange end must be considered for sizes under 3".

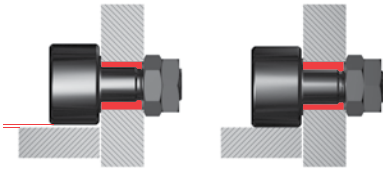

### Eccentric Stud

Eccentric stud option provides a means of adjusting the radial position of the bearing which can improve the load sharing of inline bearing combinations. Cam follower load sharing helps reduce operation costs by reducing premature failures due to overloaded bearings, the need of precise mounting hole location tolerances and providing ability to realign bearing due to track wear. Eccentric bushing is press fit on stud and unhardened to permit dowel or setscrew for permanent locking.



### Bushing Type

Non-Metallic bushing provides load support with a sliding motion that reduces the need for bearing lubrication for non-food applications where relubrication is not convenient or grease contamination in the process is not acceptable. Max allowable continuous operating temperature up to 200°F. Bushing CAMROL bearings are intended to be used in the self lubricated mode. However, continuous feed oil lubrication can be used to provide reduced wear rates. Grease lubrication should not be used.



### Corrosion Resistance

McGill CAMROL Cam Followers are available in 400 series corrosion resistant components for improved resistance to both external and internal corrosion. CRES CAMROL bearings are dimensionally interchangeable with standard CAMROL<sup>®</sup> bearings and easily identifiable with "CR" designation. Please see page K-3 for more information and availability.

## Additional Options



**BHT**  
Hex hole at threaded end of cam follower stud.



**THT**  
Threaded axial lubrication hole at threaded end of cam follower stud.



**THF**  
Threaded axial lubrication hole at flanged end of cam follower stud. Available with all screw driver slot cam followers or broached cam followers over 3”.



**THB**  
Threaded axial oil hole on both ends of cam follower stud. Available with all screw driver slot cam followers or broached cam followers over 3”.



**ALG**  
Annular lubrication groove at cam follower stud radial lubrication hole.

## **Custom Capabilities**

- *Customer specified factory grease fill*
- *Grease fitting installed*
- *Stud or thread length modifications*
- *Roller diameter variations or tolerances*
- *Cam followers grouped or matched diameter tolerance / run out sets*
- *Custom engineered to order designs*

# McGILL® Inch Cam Follower Bearings



- Basic Construction Type:** Stud Type Crowned / Cylindrical Outside Diameter
- Rolling Elements:** Full Complement Needle Roller
- Bearing Material:** Bearing Quality Steel
- Seal Type:** LUBRI-DISC®
- Lubrication:** Lithium Soap Grease NLGI #2
- System Configuration:** Concentric / Eccentric / Heavy Stud
- Mounting Feature:** Slot / Hex Hole

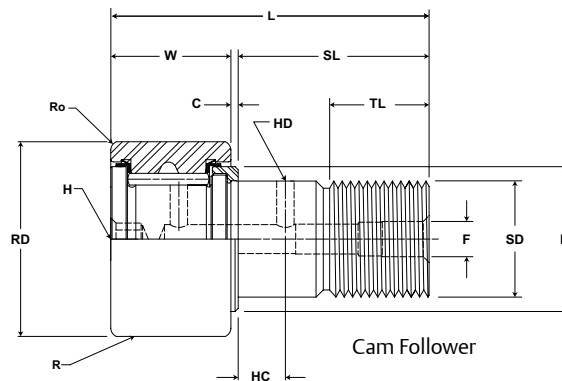

## CF, CFE, CFH

Part No.		RD		W		SD		SL	C	TL	L	R	ECC	G	BD	Track Roller Dynamic Rating	Track Roller Static Rating
W/O Seals	With LUBRI-DISC Seals	Roller Diameter		Roller Width		Stud Diameter		Stud Length	Endplate Extension	Min Thread Length	Length Overall	Crown Prefix CCF-XX	Eccentric Base Modifier CFE-XX				
		inch mm		inch mm		inch mm		inch mm		inch mm		inch mm	inch mm				
		Nom.	Tol.	Nom.	Tol.	Nom.	Tol.	(Ref)	(Ref)	(Ref)	(Ref)	Radius (Ref)	(Ref)	+0/-0.010	±.001		
CF 1/2	CF 1/2 S											Cylindrical				680 3,025	790 3,514
CF 1/2 B	CF 1/2 SB	.500	+0/-0.001	.375	+0 / -0.005	.190	+0.01/-0	.63	.031	.25	1.03	7 178	N/A	N/A	N/A		
CCF 1/2	CCF 1/2 S	12.70	+0/-0.03	9.53	+0 / -0.13	4.83	+0.03/-0	15.9	.8	6.4	26.2						
CCF 1/2 B	CCF 1/2 SB																
CFE 1/2	CFE 1/2 S												Cylindrical				680 3,025
CFE 1/2 B	CFE 1/2 SB	.500	+0/-0.001	.375	+0 / -0.005	.190	+0.01/-0	.63	.031	.25	1.03	7 178	.010	.375	.250		
CCFE 1/2	CCFE 1/2 S	12.70	+0/-0.03	9.53	+0 / -0.13	4.83	+0.03/-0	15.9	.8	6.4	26.2						
CCFE 1/2 B	CCFE 1/2 SB																
CFH 1/2	CFH 1/2 S												Cylindrical				680 3,025
CFH 1/2 B	CFH 1/2 SB	.500	+0/-0.001	.375	+0 / -0.005	.190	+0.01/-0	.63	.031	.25	1.03	7 178	N/A	N/A	N/A		
CCFH 1/2	CCFH 1/2 S	12.70	+0/-0.03	9.53	+0 / -0.13	4.83	+0.03/-0	15.9	.8	6.4	26.2						
CCFH 1/2 B	CCFH 1/2 SB																
CF 1/2 N	CF 1/2 N S												Cylindrical				620 2,758
CF 1/2 N B	CF 1/2 N SB	.500	+0/-0.001	.344	+0 / -0.005	.190	+0.01/-0	.50	.031	.25	.88	6 152	N/A	N/A	N/A		
CCF 1/2 N	CCF 1/2 N S	12.70	+0/-0.03	8.74	+0 / -0.13	4.83	+0.03/-0	12.7	.8	6.4	22.2						
CCF 1/2 N B	CCF 1/2 N SB																
CFE 1/2 N	CFE 1/2 N S												Cylindrical				620 2,758
CFE 1/2 N B	CFE 1/2 N SB	.500	+0/-0.001	.344	+0 / -0.005	.190	+0.01/-0	.50	.031	.25	.88	6 152	.010	.250	.250		
CCFE 1/2 N	CCFE 1/2 N S	12.70	+0/-0.03	8.74	+0 / -0.13	4.83	+0.03/-0	12.7	.8	6.4	22.2						
CCFE 1/2 N B	CCFE 1/2 N SB																
CF 9/16	CF 9/16 S												Cylindrical				680 3,025
CF 9/16 B	CF 9/16 SB	.5625	+0/-0.001	.375	+0 / -0.005	.190	+0.01/-0	.63	.031	.25	1.03	7 178	N/A	N/A	N/A		
CCF 9/16	CCF 9/16 S	14.29	+0/-0.03	9.53	+0 / -0.13	4.83	+0.03/-0	15.9	.8	6.4	26.2						
CCF 9/16 B	CCF 9/16 SB																
CFE 9/16	CFE 9/16 S												Cylindrical				680 3,025
CFE 9/16 B	CFE 9/16 SB	.5625	+0/-0.001	.375	+0 / -0.005	.190	+0.01/-0	.63	.031	.25	1.03	7 178	.010	.375	.250		
CCFE 9/16	CCFE 9/16 S	14.29	+0/-0.03	9.53	+0 / -0.13	4.83	+0.03/-0	15.9	.8	6.4	26.2						
CCFE 9/16 B	CCFE 9/16 SB																
CFH 9/16	CFH 9/16 S												Cylindrical				680 3,025
CFH 9/16 B	CFH 9/16 SB	.5625	+0/-0.001	.375	+0 / -0.005	.250	+0.01/-0	.63	.031	.25	1.03	7 178	N/A	N/A	N/A		
CCFH 9/16	CCFH 9/16 S	14.29	+0/-0.03	9.53	+0 / -0.13	6.35	+0.03/-0	15.9	.8	6.4	26.2						
CCFH 9/16 B	CCFH 9/16 SB																

Metric dimensions for reference only.  
 Hex wrench size for "Broached" version is located in the wrench size chart on page B-156.  
 Not all parts are available from stock. Please contact customer service for availability (800) 626-2120.  
 For more information on bearing capabilities outside of our standard offering, please contact Application Engineering (800) 626-2093.

# Inch Cam Follower Bearings **MCGILL**

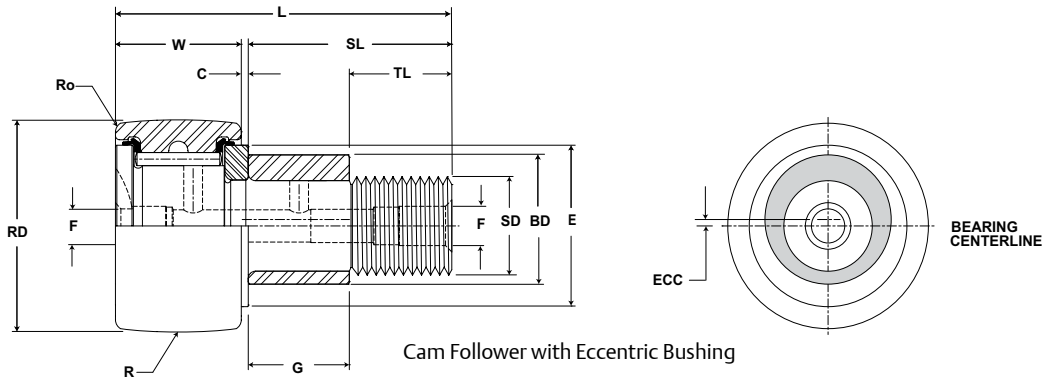

## CF, CFE, CFH

Part No.		HC	HD	F	E	Ro	HBD		Thread Type	Clamping Torque	Limiting Speed (Grease)	WT
W/O Seals	With LUBRI-DISC Seals	Hole Center	Radial Hole Diameter	Axial Hole Dia or Fitting	Min Boss Diameter	Outer Corner	Housing Bore Diameter					
		inch mm		inch mm		inch mm						
		(Ref)	(Ref)	(Ref)	(Ref)	Nom.	Tol.	in-lb Nm				
CF 1/2	CF 1/2 S	-	-	.125	.410	.016	.1903	+0.002/-0.003	10-32	15 2	11,500	.04 .02
CF 1/2 B	CF 1/2 SB			3.175	10.41	.40	4.834	+0.005/-0.008				
CCF 1/2	CCF 1/2 S					N/A						
CCF 1/2 B	CCF 1/2 SB											
CFE 1/2	CFE 1/2 S	-	-	.125	.410	.016	.253	+0.001/-0.001	10-32	15 2	11,500	.04 .02
CFE 1/2 B	CFE 1/2 SB			3.175	10.41	.40	6.42	+0.025/-0.025				
CCFE 1/2	CCFE 1/2 S					N/A						
CCFE 1/2 B	CCFE 1/2 SB											
CFH 1/2	CFH 1/2 S	-	-	.125	.410	.016	.2503	+0.002/-0.003	1/4-28	35 4	11,500	.04 .02
CFH 1/2 B	CFH 1/2 SB			3.175	10.41	.40	6.358	+0.005/-0.008				
CCFH 1/2	CCFH 1/2 S					N/A						
CCFH 1/2 B	CCFH 1/2 SB											
CF 1/2 N	CF 1/2 N S	-	-	.125	.410	.016	.1903	+0.002/-0.003	10-32	15 2	11,500	.04 .02
CF 1/2 N B	CF 1/2 N SB			3.175	10.41	.40	4.834	+0.005/-0.008				
CCF 1/2 N	CCF 1/2 N S					N/A						
CCF 1/2 N B	CCF 1/2 N SB											
CFE 1/2 N	CFE 1/2 N S	-	-	.125	.410	.016	.253	+0.001/-0.001	10-32	15 2	11,500	.04 .02
CFE 1/2 N B	CFE 1/2 N SB			3.175	10.41	.40	6.42	+0.025/-0.025				
CCFE 1/2 N	CCFE 1/2 N S					N/A						
CCFE 1/2 N B	CCFE 1/2 N SB											
CF 9/16	CF 9/16 S	-	-	.125	.410	.016	.1903	+0.002/-0.003	10-32	15 2	10,000	.04 .02
CF 9/16 B	CF 9/16 SB			3.175	10.41	.40	4.834	+0.005/-0.008				
CCF 9/16	CCF 9/16 S					N/A						
CCF 9/16 B	CCF 9/16 SB											
CFE 9/16	CFE 9/16 S	-	-	.125	.410	.016	.253	+0.001/-0.001	10-32	15 2	11,500	.04 .02
CFE 9/16 B	CFE 9/16 SB			3.175	10.41	.40	6.42	+0.025/-0.025				
CCFE 9/16	CCFE 9/16 S					N/A						
CCFE 9/16 B	CCFE 9/16 SB											
CFH 9/16	CFH 9/16 S	-	-	.125	.410	.016	.2503	+0.002/-0.003	1/4-28	35 4	10,000	.04 .02
CFH 9/16 B	CFH 9/16 SB			3.175	10.41	.40	6.358	+0.005/-0.008				
CCFH 9/16	CCFH 9/16 S					N/A						
CCFH 9/16 B	CCFH 9/16 SB											

For positive clamping, use housing thickness equal to G dimension  $\pm .010$ .  
Clamping torque is based on dry threads. If threads are lubricated, use half of value shown.  
Hex wrench size for "Broached" version is located in the wrench size chart on page B-156.



# MCGILL® Inch Cam Follower Bearings



- Basic Construction Type:** Stud Type Crowned / Cylindrical Outside Diameter
- Rolling Elements:** Full Complement Needle Roller
- Bearing Material:** Bearing Quality Steel
- Seal Type:** LUBRI-DISC®
- Lubrication:** Lithium Soap Grease NLGI #2
- System Configuration:** Concentric / Eccentric / Heavy Stud
- Mounting Feature:** Slot / Hex Hole

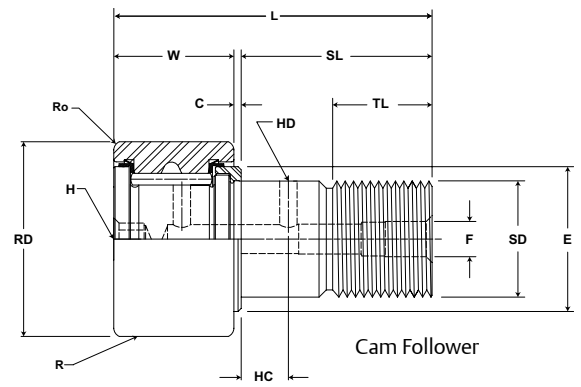

## CF, CFE, CFH

Part No.		RD		W		SD		SL	C	TL	L	R	ECC	G	BD	Track Roller Dynamic Rating	Track Roller Static Rating
W/O Seals	With LUBRI-DISC Seals	Roller Diameter		Roller Width		Stud Diameter		Stud Length	Endplate Extension	Min Thread Length	Length Overall	Crown Prefix CCF-XX	Eccentric Base Modifier CFE-XX				
		inch mm		inch mm		inch mm		inch mm	inch mm	inch mm	inch mm	inch mm	inch mm				
		Nom.	Tol.	Nom.	Tol.	Nom.	Tol.	(Ref)	(Ref)	(Ref)	(Ref)	Radius (Ref)	(Ref)	+0/-0.010	±.001		
CF 5/8	CF 5/8 S	.625 15.88	+0/-0.001 +0/-0.03	.438 11.11	+0 / -0.005 +0 / -0.13	.250 6.35	+0.01/-0 +0.03/-0	.75 19.1	.031 .8	.31 7.9	1.22 31.0	Cylindrical	N/A	N/A	N/A	955 4,248	1,215 5,404
CF 5/8 B	CF 5/8 SB											8					
CCF 5/8	CCF 5/8 S	203															
CCF 5/8 B	CCF 5/8 SB	203															
CFE 5/8	CFE 5/8 S	.625 15.88	+0/-0.001 +0/-0.03	.438 11.11	+0 / -0.005 +0 / -0.13	.250 6.35	+0.01/-0 +0.03/-0	.75 19.1	.031 .8	.31 7.9	1.22 31.0	Cylindrical	.015 .38	.437 11.10	.375 9.53	955 4,248	1,215 5,404
CFE 5/8 B	CFE 5/8 SB											8					
CCFE 5/8	CCFE 5/8 S	203															
CCFE 5/8 B	CCFE 5/8 SB	203															
CFH 5/8	CFH 5/8 S	.625 15.88	+0/-0.001 +0/-0.03	.438 11.11	+0 / -0.005 +0 / -0.13	.3125 7.94	+0.01/-0 +0.03/-0	.75 19.1	.031 .8	.31 7.9	1.22 31.0	Cylindrical	N/A	N/A	N/A	955 4,248	2,480 11,031
CFH 5/8 B	CFH 5/8 SB											8					
CCFH 5/8	CCFH 5/8 S	203															
CCFH 5/8 B	CCFH 5/8 SB	203															
CF 5/8 N	CF 5/8 N S	.625 15.88	+0/-0.001 +0/-0.03	.406 10.31	+0 / -0.005 +0 / -0.13	.250 6.35	+0.01/-0 +0.03/-0	.63 15.9	.031 .8	.31 7.9	1.06 27.0	Cylindrical	N/A	N/A	N/A	930 4,137	1,085 4,826
CF 5/8 N B	CF 5/8 N SB											7					
CCF 5/8 N	CCF 5/8 N S	178															
CCF 5/8 N B	CCF 5/8 N SB	178															
CCFE 5/8 N	CCFE 5/8 N S	178															
CCFE 5/8 N B	CCFE 5/8 N SB	178															
CF 11/16	CF 11/16 S	.688 17.46	+0/-0.001 +0/-0.03	.438 11.11	+0 / -0.005 +0 / -0.13	.250 6.35	+0.01/-0 +0.03/-0	.75 19.1	.031 .8	.31 7.9	1.22 31.0	Cylindrical	N/A	N/A	N/A	955 4,248	1,215 5,404
CF 11/16 B	CF 11/16 SB											8					
CCF 11/16	CCF 11/16 S	203															
CCF 11/16 B	CCF 11/16 SB	203															
CFE 11/16	CFE 11/16 S	.688 17.46	+0/-0.001 +0/-0.03	.438 11.11	+0 / -0.005 +0 / -0.13	.250 6.35	+0.01/-0 +0.03/-0	.75 19.1	.031 .8	.31 7.9	1.22 31.0	Cylindrical	.015 .38	.437 11.10	.375 9.53	955 4,248	1,215 5,404
CFE 11/16 B	CFE 11/16 SB											8					
CCFE 11/16	CCFE 11/16 S	203															
CCFE 11/16 B	CCFE 11/16 SB	203															
CFH 11/16	CFH 11/16 S	.688 17.46	+0/-0.001 +0/-0.03	.438 11.11	+0 / -0.005 +0 / -0.13	.3125 7.94	+0.01/-0 +0.03/-0	.75 19.1	.031 .8	.31 7.9	1.22 31.0	Cylindrical	N/A	N/A	N/A	955 4,248	2,480 11,031
CFH 11/16 B	CFH 11/16 SB											8					
CCFH 11/16	CCFH 11/16 S	203															
CCFH 11/16 B	CCFH 11/16 SB	203															

Metric dimensions for reference only.  
Hex wrench size for "Broached" version is located in the wrench size chart on page B-156.

Not all parts are available from stock. Please contact customer service for availability (800) 626-2120.  
For more information on bearing capabilities outside of our standard offering, please contact Application Engineering (800) 626-2093.

# Inch Cam Follower Bearings **McGILL**

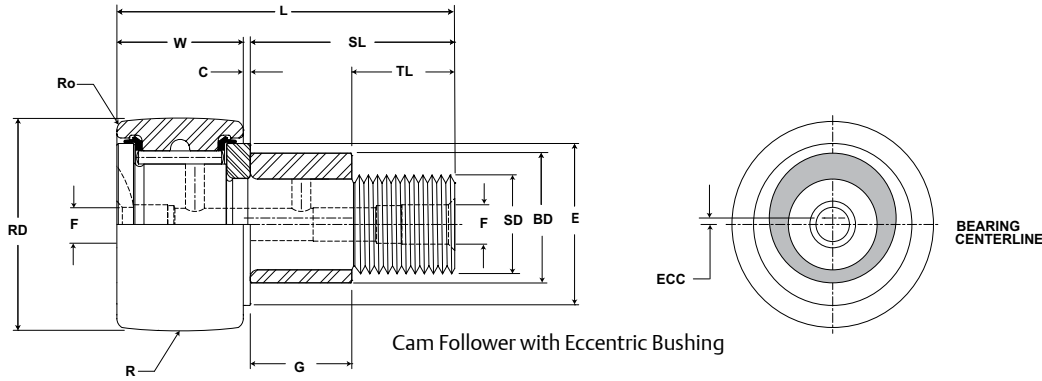

## CF, CFE, CFE

Part No.		HC	HD	F	E	Ro	HBD		Thread Type	Clamping Torque	Limiting Speed (Grease)	WT
W/O Seals	With LUBRI-DISC Seals	Hole Center	Radial Hole Diameter	Axial Hole Dia or Fitting	Min Boss Diameter	Outer Corner	Housing Bore Diameter					
		inch mm		inch mm		inch mm						
		(Ref)	(Ref)	(Ref)	(Ref)	Nom.	Tol.	in-lb Nm				
CF 5/8	CF 5/8 S	-	-	.125 3.175	.462 11.73	.016 .40	.2503 6.358	+.0002/- .0003 +.0005/- .0008	1/4-28	35 4	9,200	.05 .02
CF 5/8 B	CF 5/8 SB					N/A						
CCF 5/8	CCF 5/8 S											
CCF 5/8 B	CCF 5/8 SB											
CFE 5/8	CFE 5/8 S	-	-	.125 3.175	.462 11.73	.016 .40	.378 9.60	+.001/- .001 +.025/- .025	5/16-24	90 10	9,200	.05 .02
CFE 5/8 B	CFE 5/8 SB					N/A						
CCFE 5/8	CCFE 5/8 S											
CCFE 5/8 B	CCFE 5/8 SB											
CFH 5/8	CFH 5/8 S	-	-	.125 3.175	.462 11.73	.016 .40	.3128 7.945	+.0002/- .0003 +.0005/- .0008	5/16-24	90 10	9,200	.05 .02
CFH 5/8 B	CFH 5/8 SB					N/A						
CCFH 5/8	CCFH 5/8 S											
CCFH 5/8 B	CCFH 5/8 SB											
CF 5/8 N	CF 5/8 N S	-	-	.125 3.175	.462 11.73	.016 .40	.2503 6.358	+.0002/- .0003 +.0005/- .0008	1/4-28	35 4	9,200	.05 .02
CF 5/8 N B	CF 5/8 N SB					N/A						
CCF 5/8 N	CCF 5/8 N S											
CCF 5/8 N B	CCF 5/8 N SB											
CCFE 5/8 N	CCFE 5/8 N S											
CF 11/16	CF 11/16 S	-	-	.125 3.175	.462 11.73	.016 .40	.2503 6.358	+.0002/- .0003 +.0005/- .0008	1/4-28	35 4	8,300	.06 .03
CF 11/16 B	CF 11/16 SB					N/A						
CCF 11/16	CCF 11/16 S											
CCF 11/16 B	CCF 11/16 SB											
CFE 11/16	CFE 11/16 S	-	-	.125 3.175	.462 11.73	.016 .40	.378 9.60	+.001/- .001 +.025/- .025	5/16-24	90 10	8,300	.06 .03
CFE 11/16 B	CFE 11/16 SB					N/A						
CCFE 11/16	CCFE 11/16 S											
CCFE 11/16 B	CCFE 11/16 SB											
CFH 11/16	CFH 11/16 S	-	-	.125 3.175	.462 11.73	.016 .40	.3128 7.945	+.0002/- .0003 +.0005/- .0008	5/16-24	90 10	8,300	.06 .03
CFH 11/16 B	CFH 11/16 SB					N/A						
CCFH 11/16	CCFH 11/16 S											
CCFH 11/16 B	CCFH 11/16 SB											

For positive clamping, use housing thickness equal to G dimension  $\pm .010$ ".  
Clamping torque is based on dry threads. If threads are lubricated, use half of value shown.  
Hex wrench size for "Broached" version is located in the wrench size chart on page B-156.

# MCGILL® Inch Cam Follower Bearings



- Basic Construction Type:** Stud Type Crowned / Cylindrical Outside Diameter
- Rolling Elements:** Full Complement Needle Roller
- Bearing Material:** Bearing Quality Steel
- Seal Type:** LUBRI-DISC®
- Lubrication:** Lithium Soap Grease NLGI #2
- System Configuration:** Concentric / Eccentric / Heavy Stud
- Mounting Feature:** Slot / Hex Hole

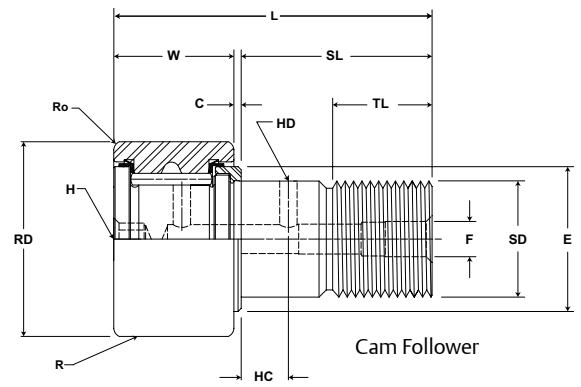

## CF, CFE, CFH

Part No.		RD		W		SD		SL	C	TL	L	R	ECC	G	BD	Track Roller Dynamic Rating	Track Roller Static Rating
W/O Seals	With LUBRI-DISC Seals	Roller Diameter		Roller Width		Stud Diameter		Stud Length	Endplate Extension	Min Thread Length	Length Overall	Crown Prefix CCF-XX	Eccentric Base Modifier CFE-XX				
		inch mm		inch mm		inch mm		inch mm		inch mm		inch mm	inch mm				
		Nom.	Tol.	Nom.	Tol.	Nom.	Tol.	(Ref)	(Ref)	(Ref)	(Ref)	Radius (Ref)	(Ref)	+0/-0.010	±.001		
CF 3/4	CF 3/4 S	.750 19.05	+0/-0.001 +0/-0.03	.500 12.70	+0 / - .005 +0 / - .13	.375 9.53	+0.01/-0 +0.03/-0	.88 22.2	.031 .8	.38 9.5	1.41 35.7	Cylindrical	N/A	N/A	N/A	1,660 7,384	2,065 9,185
CF 3/4 B	CF 3/4 SB											10					
CCF 3/4	CCF 3/4 S											254					
CCF 3/4 B	CCF 3/4 SB											254					
CFE 3/4	CFE 3/4 S	.750 19.05	+0/-0.001 +0/-0.03	.500 12.70	+0 / - .005 +0 / - .13	.375 9.53	+0.01/-0 +0.03/-0	.88 22.2	.031 .8	.38 9.5	1.41 35.7	Cylindrical	.015 .38	.500 12.70	.500 12.70	1,660 7,384	2,065 9,185
CFE 3/4 B	CFE 3/4 SB											10					
CCFE 3/4	CCFE 3/4 S											254					
CCFE 3/4 B	CCFE 3/4 SB											254					
CFH 3/4	CFH 3/4 S	.750 19.05	+0/-0.001 +0/-0.03	.500 12.70	+0 / - .005 +0 / - .13	.4375 11.11	+0.01/-0 +0.03/-0	.88 22.2	.031 .8	.38 9.5	1.41 35.7	Cylindrical	N/A	N/A	N/A	1,660 7,384	4,130 18,370
CFH 3/4 B	CFH 3/4 SB											10					
CCFH 3/4	CCFH 3/4 S											254					
CCFH 3/4 B	CCFH 3/4 SB											254					
CF 7/8	CF 7/8 S	.875 22.23	+0/-0.001 +0/-0.03	.500 12.70	+0 / - .005 +0 / - .13	.375 9.53	+0.01/-0 +0.03/-0	.88 22.2	.031 .8	.38 9.5	1.41 35.7	Cylindrical	N/A	N/A	N/A	1,660 7,384	2,065 9,185
CF 7/8 B	CF 7/8 SB											10					
CCF 7/8	CCF 7/8 S											254					
CCF 7/8 B	CCF 7/8 SB											254					
CFE 7/8	CFE 7/8 S	.875 22.23	+0/-0.001 +0/-0.03	.500 12.70	+0 / - .005 +0 / - .13	.375 9.53	+0.01/-0 +0.03/-0	.88 22.2	.031 .8	.38 9.5	1.41 35.7	Cylindrical	.015 .38	.500 12.70	.500 12.70	1,660 7,384	2,065 9,185
CFE 7/8 B	CFE 7/8 SB											10					
CCFE 7/8	CCFE 7/8 S											254					
CCFE 7/8 B	CCFE 7/8 SB											254					
CFH 7/8	CFH 7/8 S	.875 22.23	+0/-0.001 +0/-0.03	.500 12.70	+0 / - .005 +0 / - .13	.4375 11.11	+0.01/-0 +0.03/-0	.88 22.2	.031 .8	.38 9.5	1.41 35.7	Cylindrical	N/A	N/A	N/A	1,660 7,384	4,130 18,370
CFH 7/8 B	CFH 7/8 SB											10					
CCFH 7/8	CCFH 7/8 S											254					
CCFH 7/8 B	CCFH 7/8 SB											254					

Metric dimensions for reference only.  
Hex wrench size for "Broached" version is located in the wrench size chart on page B-156.

Not all parts are available from stock. Please contact customer service for availability (800) 626-2120.  
For more information on bearing capabilities outside of our standard offering, please contact Application Engineering (800) 626-2093.

# Inch Cam Follower Bearings **MCGILL**

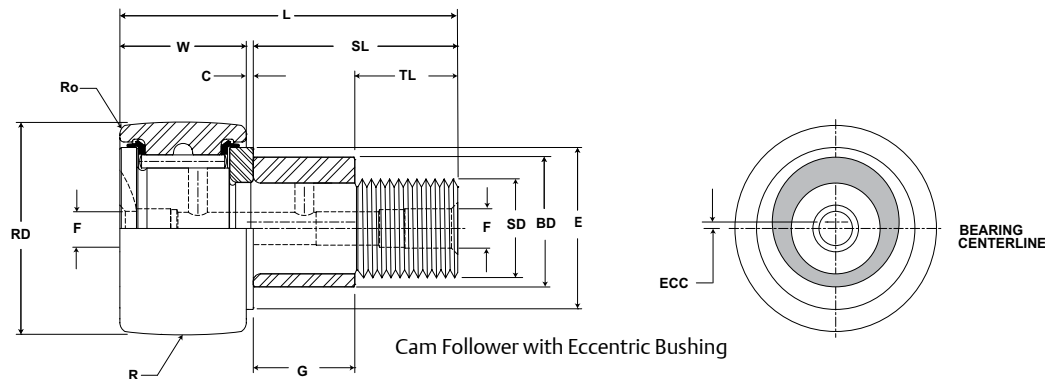

## CF, CFE, CFH

Part No.		HC	HD	F	E	Ro	HBD		Thread Type	Clamping Torque	Limiting Speed (Grease)	WT
W/O Seals	With LUBRI-DISC Seals	Hole Center	Radial Hole Diameter	Axial Hole Dia or Fitting	Min Boss Diameter	Outer Corner	Housing Bore Diameter					
		inch mm		inch mm		inch mm						
		(Ref)	(Ref)	(Ref)	(Ref)	(Ref)	Nom.	Tol.				
CF 3/4	CF 3/4 S	.25 6	.0938 2	.1875 5	.609 15.48	.016 .40	.3753 9.533	+.0002/- .0003 +.0005/- .0008	3/8-24	95 11	6,400	.07 .03
CF 3/4 B	CF 3/4 SB					N/A						
CCF 3/4	CCF 3/4 S					N/A						
CCF 3/4 B	CCF 3/4 SB					N/A						
CFE 3/4	CFE 3/4 S	.25 6	.0938 2	.1875 5	.609 15.48	.016 .40	.503 12.77	+.001/- .001 +.025/- .025	7/16-20	250 28	6,400	.08 .04
CFE 3/4 B	CFE 3/4 SB					N/A						
CCFE 3/4	CCFE 3/4 S					N/A						
CCFE 3/4 B	CCFE 3/4 SB					N/A						
CFH 3/4	CFH 3/4 S	.25 6	.0938 2	.1875 5	.609 15.48	.016 .40	.4378 11.120	+.0002/- .0003 +.0005/- .0008	7/16-20	250 28	6,400	.08 .04
CFH 3/4 B	CFH 3/4 SB					N/A						
CCFH 3/4	CCFH 3/4 S					N/A						
CCFH 3/4 B	CCFH 3/4 SB					N/A						
CF 7/8	CF 7/8 S	.25 6	.0938 2	.1875 5	.609 15.48	.016 .40	.3753 9.533	+.0002/- .0003 +.0005/- .0008	3/8-24	95 11	5,400	.09 .04
CF 7/8 B	CF 7/8 SB					N/A						
CCF 7/8	CCF 7/8 S					N/A						
CCF 7/8 B	CCF 7/8 SB					N/A						
CFE 7/8	CFE 7/8 S	.25 6	.0938 2	.1875 5	.609 15.48	.016 .40	.503 12.77	+.001/- .001 +.025/- .025	7/16-20	250 28	5,400	.11 .05
CFE 7/8 B	CFE 7/8 SB					N/A						
CCFE 7/8	CCFE 7/8 S					N/A						
CCFE 7/8 B	CCFE 7/8 SB					N/A						
CFH 7/8	CFH 7/8 S	.25 6	.0938 2	.1875 5	.609 15.48	.016 .40	.4378 11.120	+.0002/- .0003 +.0005/- .0008	7/16-20	250 28	5,400	.11 .05
CFH 7/8 B	CFH 7/8 SB					N/A						
CCFH 7/8	CCFH 7/8 S					N/A						
CCFH 7/8 B	CCFH 7/8 SB					N/A						

For positive clamping, use housing thickness equal to G dimension  $\pm .010$ ".  
Clamping torque is based on dry threads. If threads are lubricated, use half of value shown.  
Hex wrench size for "Broached" version is located in the wrench size chart on page B-156.

# McGILL® Inch Cam Follower Bearings



- Basic Construction Type:** Stud Type Crowned / Cylindrical Outside Diameter
- Rolling Elements:** Full Complement Needle Roller
- Bearing Material:** Bearing Quality Steel
- Seal Type:** LUBRI-DISC®
- Lubrication:** Lithium Soap Grease NLGI #2
- System Configuration:** Concentric / Eccentric / Heavy Stud
- Mounting Feature:** Slot / Hex Hole

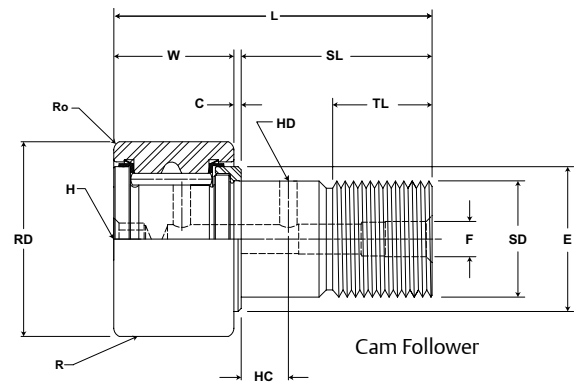

## CF, CFE, CFH

Part No.		RD		W		SD		SL	C	TL	L	R	ECC	G	BD	Track Roller Dynamic Rating	Track Roller Static Rating	
W/O Seals	With LUBRI-DISC Seals	Roller Diameter		Roller Width		Stud Diameter		Stud Length	Endplate Extension	Min Thread Length	Length Overall	Crown Prefix CCF-XX	Eccentric Base Modifier CFE-XX					
		inch mm		inch mm		inch mm		inch mm		inch mm		inch mm		inch mm				
		Nom.	Tol.	Nom.	Tol.	Nom.	Tol.	(Ref)	(Ref)	(Ref)	(Ref)	Radius (Ref)	(Ref)	+0/-0.010	±.001			lb/N
CF 1	CF 1 S											Cylindrical				2,225 9,897	3,060 13,611	
CF 1 B	CF 1 SB	1.000	+0/-0.001	.625	+0 / -.005	.4375	+0.01/-0	1.00	.031	.50	1.66	12 305	N/A	N/A	N/A			
CCF 1	CCF 1 S	25.40	+0/-0.03	15.88	+0 / -.13	11.11	+0.3/-0	25.4	.8	12.7	42.1							
CCF 1 B	CCF 1 SB																	
CFE 1	CFE 1 S											Cylindrical				2,225 9,897	6,120 27,222	
CFE 1 B	CFE 1 SB	1.000	+0/-0.001	.625	+0 / -.005	.4375	+0.01/-0	1.00	.031	.50	1.66	12 305	.030	.500	.625			
CCFE 1	CCFE 1 S	25.40	+0/-0.03	15.88	+0 / -.13	11.11	+0.3/-0	25.4	.8	12.7	42.1			12.70	15.88			
CCFE 1 B	CCFE 1 SB																	
CFH 1	CFH 1 S											Cylindrical				2,225 9,897	6,120 27,222	
CFH 1 B	CFH 1 SB	1.000	+0/-0.001	.625	+0 / -.005	.625	+0.01/-0	1.00	.031	.50	1.66	12 305	N/A	N/A	N/A			
CCFH 1	CCFH 1 S	25.40	+0/-0.03	15.88	+0 / -.13	15.88	+0.3/-0	25.4	.8	12.7	42.1							
CCFH 1 B	CCFH 1 SB																	
CF 1 1/8	CF 1 1/8 S											Cylindrical				2,225 9,897	3,060 13,611	
CF 1 1/8 B	CF 1 1/8 SB	1.125	+0/-0.001	.625	+0 / -.005	.4375	+0.01/-0	1.00	.031	.50	.031	12 305	N/A	N/A	N/A			
CCF 1 1/8	CCF 1 1/8 S	28.58	+0/-0.03	15.88	+0 / -.13	11.11	+0.3/-0	25.4	.8	12.7	.8							
CCF 1 1/8 B	CCF 1 1/8 SB																	
CFE 1 1/8	CFE 1 1/8 S											Cylindrical				2,225 9,897	6,120 27,222	
CFE 1 1/8 B	CFE 1 1/8 SB	1.125	+0/-0.001	.625	+0 / -.005	.4375	+0.01/-0	1.00	.031	.50	1.66	12 305	.030	.500	.625			
CCFE 1 1/8	CCFE 1 1/8 S	28.58	+0/-0.03	15.88	+0 / -.13	11.11	+0.3/-0	25.4	.8	12.7	42.1			12.70	15.88			
CCFE 1 1/8 B	CCFE 1 1/8 SB																	
CFH 1 1/8	CFH 1 1/8 S											Cylindrical				2,225 9,897	6,120 27,222	
CFH 1 1/8 B	CFH 1 1/8 SB	1.125	+0/-0.001	.625	+0 / -.005	.625	+0.01/-0	1.00	.031	.50	1.66	12 305	N/A	N/A	N/A			
CCFH 1 1/8	CCFH 1 1/8 S	28.58	+0/-0.03	15.88	+0 / -.13	15.88	+0.3/-0	25.4	.8	12.7	42.1							
CCFH 1 1/8 B	CCFH 1 1/8 SB																	

Metric dimensions for reference only.  
Hex wrench size for "Broached" version is located in the wrench size chart on page B-156.

Not all parts are available from stock. Please contact customer service for availability (800) 626-2120.  
For more information on bearing capabilities outside of our standard offering, please contact Application Engineering (800) 626-2093.

# Inch Cam Follower Bearings **McGILL**

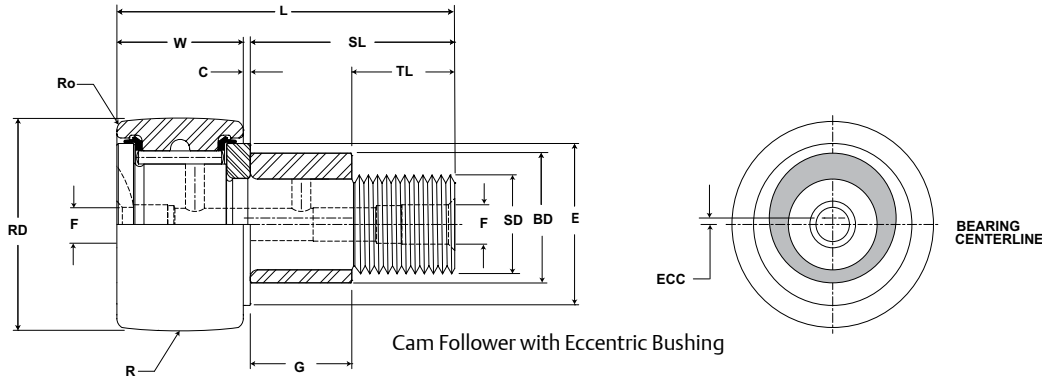

CF, CFE, CFH

Part No.		HC	HD	F	E	Ro	HBD		Thread Type	Clamping Torque	Limiting Speed (Grease)	WT
W/O Seals	With LUBRI-DISC Seals	Hole Center	Radial Hole Diameter	Axial Hole Dia or Fitting	Min Boss Diameter	Outer Corner	Housing Bore Diameter					
		inch mm		inch mm		inch mm						
		(Ref)	(Ref)	(Ref)	(Ref)	(Ref)	Nom.	Tol.				
CF 1	CF 1 S	.25 6	.0938 2	.1875 5	.781 19.84	.031 .79	.4378 11.120	+.0002/- .0003 +.0005/- .0008	7/16-20	250 28	4,800	.17 .08
CF 1 B	CF 1 SB					N/A						
CCF 1	CCF 1 S					N/A						
CCF 1 B	CCF 1 SB					N/A						
CFE 1	CFE 1 S	.25 6	.0938 2	.1875 5	.781 19.84	.031 .79	.628 15.95	+.001/- .001 +.025/- .025	5/8-18	650 73	4,800	.20 .09
CFE 1 B	CFE 1 SB					N/A						
CCFE 1	CCFE 1 S					N/A						
CCFE 1 B	CCFE 1 SB					N/A						
CFH 1	CFH 1 S	.25 6	.0938 2	.1875 5	.781 19.84	.031 .79	.6253 15.883	+.0002/- .0003 +.0005/- .0008	7/16-20	250 28	3,400	.19 .09
CFH 1 B	CFH 1 SB					N/A						
CCFH 1	CCFH 1 S					N/A						
CCFH 1 B	CCFH 1 SB					N/A						
CF 1 1/8	CF 1 1/8 S	.25 6	.0938 2	.1875 5	.781 19.84	.031 .79	.4378 11.120	+.0002/- .0003 +.0005/- .0008	5/8-18	650 73	3,400	.24 .11
CF 1 1/8 B	CF 1 1/8 SB					N/A						
CCF 1 1/8	CCF 1 1/8 S					N/A						
CCF 1 1/8 B	CCF 1 1/8 SB					N/A						
CFE 1 1/8	CFE 1 1/8 S	.25 6	.0938 2	.1875 5	.781 19.84	.031 .79	.628 15.95	+.001/- .001 +.025/- .025	7/16-20	250 28	4,800	.17 .08
CFE 1 1/8 B	CFE 1 1/8 SB					N/A						
CCFE 1 1/8	CCFE 1 1/8 S					N/A						
CCFE 1 1/8 B	CCFE 1 1/8 SB					N/A						
CFH 1 1/8	CFH 1 1/8 S	.25 6	.0938 2	.1875 5	.781 19.84	.031 .79	.6253 15.883	+.0002/- .0003 +.0005/- .0008	5/8-18	650 73	3,400	.24 .11
CFH 1 1/8 B	CFH 1 1/8 SB					N/A						
CCFH 1 1/8	CCFH 1 1/8 S					N/A						
CCFH 1 1/8 B	CCFH 1 1/8 SB					N/A						

For positive clamping, use housing thickness equal to G dimension  $\pm .010$ ".  
Clamping torque is based on dry threads. If threads are lubricated, use half of value shown.  
Hex wrench size for "Broached" version is located in the wrench size chart on page B-156.

# MCGILL® Inch Cam Follower Bearings



- Basic Construction Type:** Stud Type Crowned / Cylindrical Outside Diameter
- Rolling Elements:** Full Complement Needle Roller
- Bearing Material:** Bearing Quality Steel
- Seal Type:** LUBRI-DISC®
- Lubrication:** Lithium Soap Grease NLGI #2
- System Configuration:** Concentric / Eccentric / Heavy Stud
- Mounting Feature:** Slot / Hex Hole

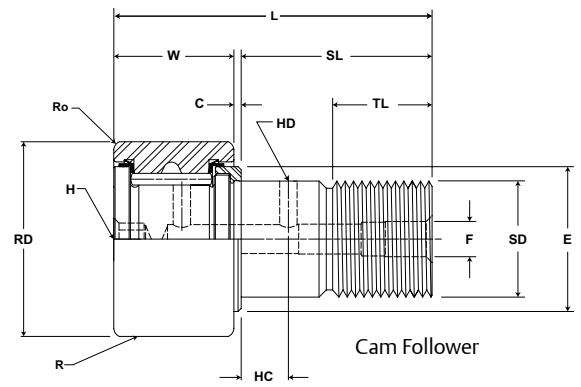

## CF, CFE, CFH

Part No.		RD		W		SD		SL	C	TL	L	R	ECC	G	BD	Track Roller Dynamic Rating	Track Roller Static Rating	
W/O Seals	With LUBRI-DISC Seals	Roller Diameter		Roller Width		Stud Diameter		Stud Length	Endplate Extension	Min Thread Length	Length Overall	Crown Prefix CCF-XX	Eccentric Base Modifier CFE-XX					
		inch mm		inch mm		inch mm		inch mm		inch mm		inch mm		inch mm				
		Nom.	Tol.	Nom.	Tol.	Nom.	Tol.	(Ref)	(Ref)	(Ref)	(Ref)	Radius (Ref)	(Ref)	+0/-0.010	±.001			lb/N
CF 1 1/4	CF 1 1/4 S	1.250 31.75	+0/-0.001 +0/-0.03	.750 19.05	+0 / -0.005 +0 / -0.13	.500 12.70	+0.01/-0 +0.03/-0	1.25 31.8	.031 .8	.63 15.9	2.03 51.6	Cylindrical	N/A	N/A	N/A	3,930 17,481	4,250 18,904	
CF 1 1/4 B	CF 1 1/4 SB											14	.030 .76	.625 15.88	.687 17.45			
CCF 1 1/4	CCF 1 1/4 S											356						
CCF 1 1/4 B	CCF 1 1/4 SB											356						
CFE 1 1/4	CFE 1 1/4 S	1.250 31.75	+0/-0.001 +0/-0.03	.750 19.05	+0 / -0.005 +0 / -0.13	.500 12.70	+0.01/-0 +0.03/-0	1.25 31.8	.031 .8	.63 15.9	2.03 51.6	Cylindrical	.030	.625	.687	3,930 17,481	8,500 37,808	
CFE 1 1/4 B	CFE 1 1/4 SB											14						
CCFE 1 1/4	CCFE 1 1/4 S											356						
CCFE 1 1/4 B	CCFE 1 1/4 SB											356						
CFH 1 1/4	CFH 1 1/4 S	1.250 31.75	+0/-0.001 +0/-0.03	.750 19.05	+0 / -0.005 +0 / -0.13	.750 19.05	+0.01/-0 +0.03/-0	1.25 31.8	.031 .8	.63 15.9	2.03 51.6	Cylindrical	N/A	N/A	N/A	3,930 17,481	8,500 37,808	
CFH 1 1/4 B	CFH 1 1/4 SB											14						
CCFH 1 1/4	CCFH 1 1/4 S											356						
CCFH 1 1/4 B	CCFH 1 1/4 SB											356						
CF 1 3/8	CF 1 3/8 S	1.375 34.93	+0/-0.001 +0/-0.03	.750 19.05	+0 / -0.005 +0 / -0.13	.500 12.70	+0.01/-0 +0.03/-0	1.25 31.8	.031 .8	.63 15.9	2.03 51.6	Cylindrical	N/A	N/A	N/A	3,930 17,481	4,250 18,904	
CF 1 3/8 B	CF 1 3/8 SB											14						
CCF 1 3/8	CCF 1 3/8 S											356						
CCF 1 3/8 B	CCF 1 3/8 SB											356						
CFE 1 3/8	CFE 1 3/8 S	1.375 34.93	+0/-0.001 +0/-0.03	.750 19.05	+0 / -0.005 +0 / -0.13	.500 12.70	+0.01/-0 +0.03/-0	1.25 31.8	.031 .8	.63 15.9	2.03 51.6	Cylindrical	.030	.625	.687	3,930 17,481	8,500 37,808	
CFE 1 3/8 B	CFE 1 3/8 SB											14						
CCFE 1 3/8	CCFE 1 3/8 S											356						
CCFE 1 3/8 B	CCFE 1 3/8 SB											356						
CFH 1 3/8	CFH 1 3/8 S	1.375 34.93	+0/-0.001 +0/-0.03	.750 19.05	+0 / -0.005 +0 / -0.13	.750 19.05	+0.01/-0 +0.03/-0	1.25 31.8	.031 .8	.63 15.9	2.03 51.6	Cylindrical	N/A	N/A	N/A	3,930 17,481	8,500 37,808	
CFH 1 3/8 B	CFH 1 3/8 SB											14						
CCFH 1 3/8	CCFH 1 3/8 S											356						
CCFH 1 3/8 B	CCFH 1 3/8 SB											356						

Metric dimensions for reference only.  
Hex wrench size for "Broached" version is located in the wrench size chart on page B-156.

Not all parts are available from stock. Please contact customer service for availability (800) 626-2120.  
For more information on bearing capabilities outside of our standard offering, please contact Application Engineering (800) 626-2093.

# Inch Cam Follower Bearings **McGILL**

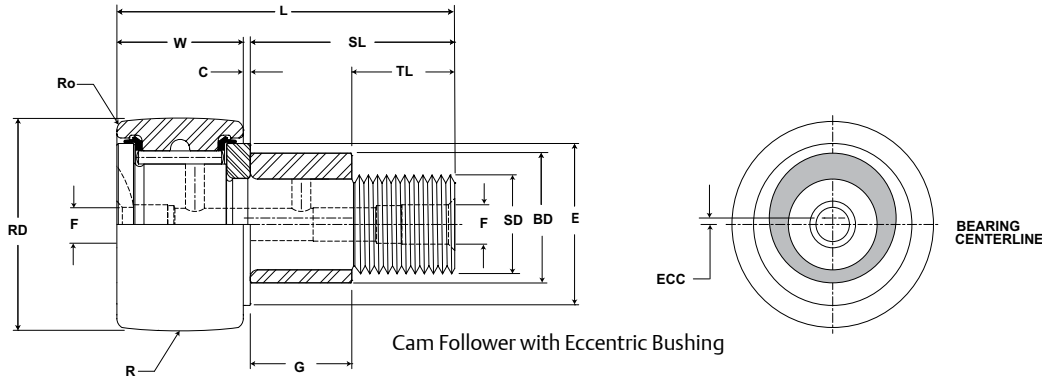

## CF, CFE, CFH

Part No.		HC	HD	F	E	Ro	HBD		Thread Type	Clamping Torque	Limiting Speed (Grease)	WT								
W/O Seals	With LUBRI-DISC Seals	Hole Center	Radial Hole Diameter	Axial Hole Dia or Fitting	Min Boss Diameter	Outer Corner	Housing Bore Diameter													
		inch mm		inch mm		inch mm														
		(Ref)	(Ref)	(Ref)	(Ref)	(Ref)	Nom.	Tol.												
CF 1 1/4	CF 1 1/4 S	.3125 8	.0938 2	.1875 5	.984 25.00	.031 .79	.5003 12.708	+.0002/- .0003 +.0005/- .0008	1/2-20	350 40	3,100	.30 .14								
CF 1 1/4 B	CF 1 1/4 SB					N/A														
CCF 1 1/4	CCF 1 1/4 S					.3125 8	.0938 2	.1875 5					.984 25.00	.031 .79	.690 17.52	+.001/- .001 +.025/- .025				
CCF 1 1/4 B	CCF 1 1/4 SB													N/A						
CFE 1 1/4	CFE 1 1/4 S	.3125 8	.0938 2	.1875 5	.984 25.00				.031 .79	.7503 19.058	+.0002/- .0003 +.0005/- .0008	3/4-16		1,250 141	3,100	.38 .17				
CFE 1 1/4 B	CFE 1 1/4 SB								N/A											
CCFH 1 1/4	CCFH 1 1/4 S					.3125 8	.0938 2	.1875 5	.984 25.00	.047 1.19	.5003 12.708		+.0002/- .0003 +.0005/- .0008				1/2-20	350 40	2,800	.35 .16
CCFH 1 1/4 B	CCFH 1 1/4 SB									N/A										
CFE 1 3/8	CFE 1 3/8 S	.3125 8	.0938 2	.1875 5	.984 25.00					.047 1.19	.690 17.52	+.001/- .001 +.025/- .025								
CFE 1 3/8 B	CFE 1 3/8 SB									N/A										
CCFH 1 3/8	CCFH 1 3/8 S					.3125 8	.0938 2	.1875 5	.984 25.00	.047 1.19	.7503 19.058	+.0002/- .0003 +.0005/- .0008	3/4-16	1,250 141	2,800	.44 .19				
CCFH 1 3/8 B	CCFH 1 3/8 SB									N/A										

For positive clamping, use housing thickness equal to G dimension  $\pm .010$ ".  
Clamping torque is based on dry threads. If threads are lubricated, use half of value shown.  
Hex wrench size for "Broached" version is located in the wrench size chart on page B-156.



# MCGILL® Inch Cam Follower Bearings



- Basic Construction Type:** Stud Type Crowned / Cylindrical Outside Diameter
- Rolling Elements:** Full Complement Needle Roller
- Bearing Material:** Bearing Quality Steel
- Seal Type:** LUBRI-DISC®
- Lubrication:** Lithium Soap Grease NLGI #2
- System Configuration:** Concentric / Eccentric / Heavy Stud
- Mounting Feature:** Slot / Hex Hole

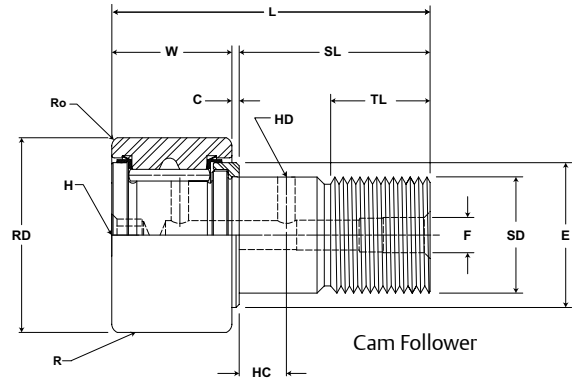

## CF, CFE, CFH

Part No.		RD		W		SD		SL	C	TL	L	R	ECC	G	BD	Track Roller Dynamic Rating	Track Roller Static Rating	
W/O Seals	With LUBRI-DISC Seals	Roller Diameter		Roller Width		Stud Diameter		Stud Length	Endplate Extension	Min Thread Length	Length Overall	Crown Prefix CCF-XX	Eccentric Base Modifier CFE-XX					
		inch mm		inch mm		inch mm		inch mm		inch mm		inch mm		inch mm				
		Nom.	Tol.	Nom.	Tol.	Nom.	Tol.	(Ref)	(Ref)	(Ref)	(Ref)	Radius (Ref)	(Ref)	+0/-0.010	±.001			lb/N
CF 1 1/2	CF 1 1/2 S	1.500 38.10	+0/-0.001 +0/-0.03	.875 22.23	+0 / -0.005 +0 / -0.13	.625 15.88	+0.01/-0 +0.03/-0	1.50 38.1	.031 .8	.75 19.1	2.41 61.1	Cylindrical	N/A	N/A	N/A	4,840 21,528	5,640 25,087	
CF 1 1/2 B	CF 1 1/2 SB											20						
CCF 1 1/2	CCF 1 1/2 S											508						
CCF 1 1/2 B	CCF 1 1/2 SB																	
CFE 1 1/2	CFE 1 1/2 S	1.500 38.10	+0/-0.001 +0/-0.03	.875 22.23	+0 / -0.005 +0 / -0.13	.625 15.88	+0.01/-0 +0.03/-0	1.50 38.1	.031 .8	.75 19.1	2.41 61.1	Cylindrical	.030	.750	.875	4,840 21,528	5,640 25,087	
CFE 1 1/2 B	CFE 1 1/2 SB											20						
CCFE 1 1/2	CCFE 1 1/2 S											508						
CCFE 1 1/2 B	CCFE 1 1/2 SB																	
CFH 1 1/2	CFH 1 1/2 S	1.500 38.10	+0/-0.001 +0/-0.03	.875 22.23	+0 / -0.005 +0 / -0.13	.875 22.23	+0.01/-0 +0.03/-0	1.50 38.1	.031 .8	.75 19.1	2.41 61.1	Cylindrical	N/A	N/A	N/A	4,840 21,528	11,280 50,173	
CFH 1 1/2 B	CFH 1 1/2 SB											20						
CCFH 1 1/2	CCFH 1 1/2 S											508						
CCFH 1 1/2 B	CCFH 1 1/2 SB																	
CF 1 5/8	CF 1 5/8 S	1.625 41.28	+0/-0.001 +0/-0.03	.875 22.23	+0 / -0.005 +0 / -0.13	.625 15.88	+0.01/-0 +0.03/-0	1.50 38.1	.031 .8	.75 19.1	2.41 61.1	Cylindrical	N/A	N/A	N/A	4,840 21,528	5,640 25,087	
CF 1 5/8 B	CF 1 5/8 SB											20						
CCF 1 5/8	CCF 1 5/8 S											508						
CCF 1 5/8 B	CCF 1 5/8 SB																	
CFE 1 5/8	CFE 1 5/8 S	1.625 41.28	+0/-0.001 +0/-0.03	.875 22.23	+0 / -0.005 +0 / -0.13	.625 15.88	+0.01/-0 +0.03/-0	1.50 38.1	.031 .8	.75 19.1	2.41 61.1	Cylindrical	.030	.750	.875	4,840 21,528	5,640 25,087	
CFE 1 5/8 B	CFE 1 5/8 SB											20						
CCFE 1 5/8	CCFE 1 5/8 S											508						
CCFE 1 5/8 B	CCFE 1 5/8 SB																	
CFH 1 5/8	CFH 1 5/8 S	1.625 41.28	+0/-0.001 +0/-0.03	.875 22.23	+0 / -0.005 +0 / -0.13	.875 22.23	+0.01/-0 +0.03/-0	1.50 38.1	.031 .8	.75 19.1	2.41 61.1	Cylindrical	N/A	N/A	N/A	4,840 21,528	11,280 50,173	
CFH 1 5/8 B	CFH 1 5/8 SB											20						
CCFH 1 5/8	CCFH 1 5/8 S											508						
CCFH 1 5/8 B	CCFH 1 5/8 SB																	

Metric dimensions for reference only.  
Hex wrench size for "Broached" version is located in the wrench size chart on page B-156.

Not all parts are available from stock. Please contact customer service for availability (800) 626-2120.  
For more information on bearing capabilities outside of our standard offering, please contact Application Engineering (800) 626-2093.

# Inch Cam Follower Bearings **McGILL**

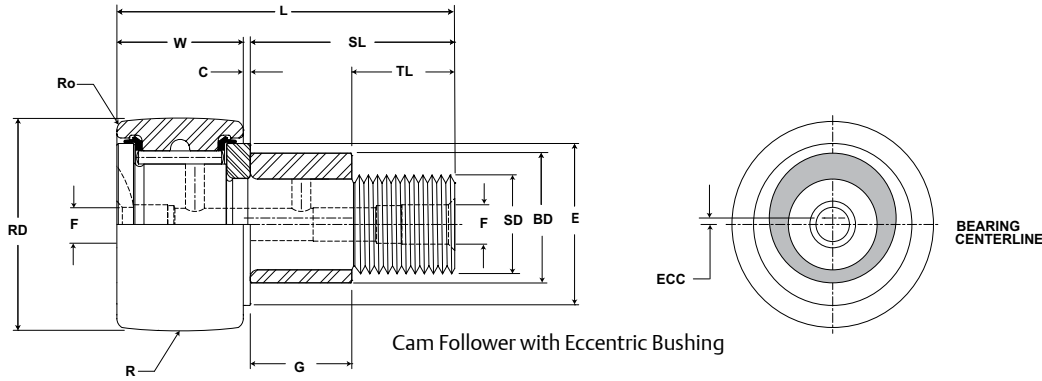

## CF, CFE, CFH

Part No.		HC	HD	F	E	Ro	HBD		Thread Type	Clamping Torque	Limiting Speed (Grease)	WT
W/O Seals	With LUBRI-DISC Seals	Hole Center	Radial Hole Diameter	Axial Hole Dia or Fitting	Min Boss Diameter	Outer Corner	Housing Bore Diameter					
		inch mm		inch mm		inch mm						
		(Ref)	(Ref)	(Ref)	(Ref)	(Ref)	Nom.	Tol.				
CF 1 1/2	CF 1 1/2 S	.375 10	.0938 2	.1875 5	1.094 27.78	.063 1.59	.6253 15.883	+.0002/- .0003 +.0005/- .0008	5/8-18	650 73	2,500	.53 .24
CF 1 1/2 B	CF 1 1/2 SB					N/A						
CCF 1 1/2	CCF 1 1/2 S					N/A						
CCF 1 1/2 B	CCF 1 1/2 SB					N/A						
CFE 1 1/2	CFE 1 1/2 S	.375 10	.0938 2	.1875 5	1.094 27.78	.063 1.59	.878 22.30	+.001/- .001 +.025/- .025	7/8-14	1,500 170	2,500	.69 .31
CFE 1 1/2 B	CFE 1 1/2 SB					N/A						
CCFE 1 1/2	CCFE 1 1/2 S					N/A						
CCFE 1 1/2 B	CCFE 1 1/2 SB					N/A						
CFH 1 1/2	CFH 1 1/2 S	.375 10	.0938 2	.1875 5	1.094 27.78	.063 1.59	.8753 22.233	+.0002/- .0003 +.0005/- .0008	7/8-14	1,500 170	2,350	.75 .34
CFH 1 1/2 B	CFH 1 1/2 SB					N/A						
CCFH 1 1/2	CCFH 1 1/2 S					N/A						
CCFH 1 1/2 B	CCFH 1 1/2 SB					N/A						
CF 1 5/8	CF 1 5/8 S	.375 10	.0938 2	.1875 5	1.094 27.78	.063 1.59	.6253 15.883	+.0002/- .0003 +.0005/- .0008	5/8-18	650 73	2,350	.60 .27
CF 1 5/8 B	CF 1 5/8 SB					N/A						
CCF 1 5/8	CCF 1 5/8 S					N/A						
CCF 1 5/8 B	CCF 1 5/8 SB					N/A						
CFE 1 5/8	CFE 1 5/8 S	.375 10	.0938 2	.1875 5	1.094 27.78	.063 1.59	.878 22.30	+.001/- .001 +.025/- .025	7/8-14	1,500 170	2,350	.75 .34
CFE 1 5/8 B	CFE 1 5/8 SB					N/A						
CCFE 1 5/8	CCFE 1 5/8 S					N/A						
CCFE 1 5/8 B	CCFE 1 5/8 SB					N/A						
CFH 1 5/8	CFH 1 5/8 S	.375 10	.0938 2	.1875 5	1.094 27.78	.063 1.59	.8753 22.233	+.0002/- .0003 +.0005/- .0008	7/8-14	1,500 170	2,350	.75 .34
CFH 1 5/8 B	CFH 1 5/8 SB					N/A						
CCFH 1 5/8	CCFH 1 5/8 S					N/A						
CCFH 1 5/8 B	CCFH 1 5/8 SB					N/A						

For positive clamping, use housing thickness equal to G dimension  $\pm .010$ ".  
Clamping torque is based on dry threads. If threads are lubricated, use half of value shown.  
Hex wrench size for "Broached" version is located in the wrench size chart on page B-156.

# MCGILL® Inch Cam Follower Bearings



- Basic Construction Type:** Stud Type Crowned / Cylindrical Outside Diameter
- Rolling Elements:** Full Complement Needle Roller
- Bearing Material:** Bearing Quality Steel
- Seal Type:** LUBRI-DISC®
- Lubrication:** Lithium Soap Grease NLGI #2
- System Configuration:** Concentric / Eccentric / Heavy Stud
- Mounting Feature:** Slot / Hex Hole

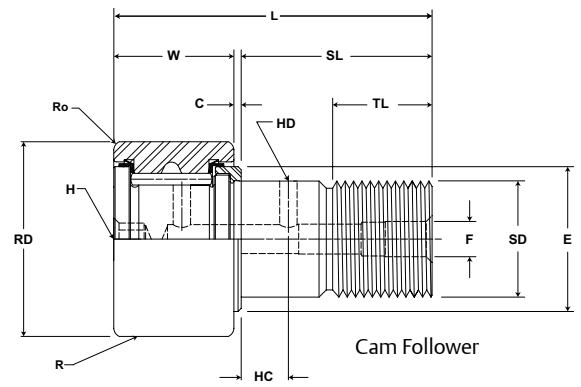

## CF, CFE, CFH

Part No.		RD		W		SD		SL	C	TL	L	R	ECC	G	BD	Track Roller Dynamic Rating	Track Roller Static Rating	
W/O Seals	With LUBRI-DISC Seals	Roller Diameter		Roller Width		Stud Diameter		Stud Length	Endplate Extension	Min Thread Length	Length Overall	Crown Prefix CCF-XX	Eccentric Base Modifier CFE-XX					
		inch mm		inch mm		inch mm		inch mm		inch mm		inch mm		inch mm				
		Nom.	Tol.	Nom.	Tol.	Nom.	Tol.	(Ref)	(Ref)	(Ref)	(Ref)	Radius (Ref)	(Ref)	+0/-0.010	±.001			lb/N
CF 1 3/4	CF 1 3/4 S	1.750 44.45	+0/-0.001 +0/-0.03	1.000 25.40	+0 / -0.005 +0 / -0.13	.750 19.05	+0.01/-0 +0.03/-0	1.75 44.5	.031 .8	.88 22.2	2.78 70.6	Cylindrical	N/A	N/A	N/A	6,385 28,400	7,920 35,228	
CF 1 3/4 B	CF 1 3/4 SB											20						
CCF 1 3/4	CCF 1 3/4 S											508						
CCF 1 3/4 B	CCF 1 3/4 SB																	
CFE 1 3/4	CFE 1 3/4 S	1.750 44.45	+0/-0.001 +0/-0.03	1.000 25.40	+0 / -0.005 +0 / -0.13	.750 19.05	+0.01/-0 +0.03/-0	1.75 44.5	.031 .8	.88 22.2	2.78 70.6	Cylindrical	.030 .76	.875 22.23	1.000 25.40	6,385 28,400	7,920 35,228	
CFE 1 3/4 B	CFE 1 3/4 SB											20						
CCFE 1 3/4	CCFE 1 3/4 S											508						
CCFE 1 3/4 B	CCFE 1 3/4 SB																	
CFH 1 3/4	CFH 1 3/4 S	1.750 44.45	+0/-0.001 +0/-0.03	1.000 25.40	+0 / -0.005 +0 / -0.13	1.000 25.40	+0.01/-0 +0.03/-0	1.75 44.5	.031 .8	.88 22.2	2.78 70.6	Cylindrical	N/A	N/A	N/A	6,385 28,400	15,840 70,456	
CFH 1 3/4 B	CFH 1 3/4 SB											20						
CCFH 1 3/4	CCFH 1 3/4 S											508						
CCFH 1 3/4 B	CCFH 1 3/4 SB																	
CF 1 7/8	CF 1 7/8 S	1.875 47.63	+0/-0.001 +0/-0.03	1.000 25.40	+0 / -0.005 +0 / -0.13	.750 19.05	+0.01/-0 +0.03/-0	1.75 44.5	.031 .8	.88 22.2	2.78 70.6	Cylindrical	N/A	N/A	N/A	6,385 28,400	7,920 35,228	
CF 1 7/8 B	CF 1 7/8 SB											20						
CCF 1 7/8	CCF 1 7/8 S											508						
CCF 1 7/8 B	CCF 1 7/8 SB																	
CFE 1 7/8	CFE 1 7/8 S	1.875 47.63	+0/-0.001 +0/-0.03	1.000 25.40	+0 / -0.005 +0 / -0.13	.750 19.05	+0.01/-0 +0.03/-0	1.75 44.5	.031 .8	.88 22.2	2.78 70.6	Cylindrical	.030 .76	.875 22.24	1.000 25.40	6,385 28,400	7,920 35,228	
CFE 1 7/8 B	CFE 1 7/8 SB											20						
CCFE 1 7/8	CCFE 1 7/8 S											508						
CCFE 1 7/8 B	CCFE 1 7/8 SB																	
CFH 1 7/8	CFH 1 7/8 S	1.875 47.63	+0/-0.001 +0/-0.03	1.000 25.40	+0 / -0.005 +0 / -0.13	1.000 25.40	+0.01/-0 +0.03/-0	1.75 44.5	.031 .8	.88 22.2	2.78 70.6	Cylindrical	N/A	N/A	N/A	6,385 28,400	15,840 70,456	
CFH 1 7/8 B	CFH 1 7/8 SB											20						
CCFH 1 7/8	CCFH 1 7/8 S											508						
CCFH 1 7/8 B	CCFH 1 7/8 SB																	

Metric dimensions for reference only.  
Hex wrench size for "Broached" version is located in the wrench size chart on page B-156.

Not all parts are available from stock. Please contact customer service for availability (800) 626-2120.  
For more information on bearing capabilities outside of our standard offering, please contact Application Engineering (800) 626-2093.

# Inch Cam Follower Bearings **McGILL**

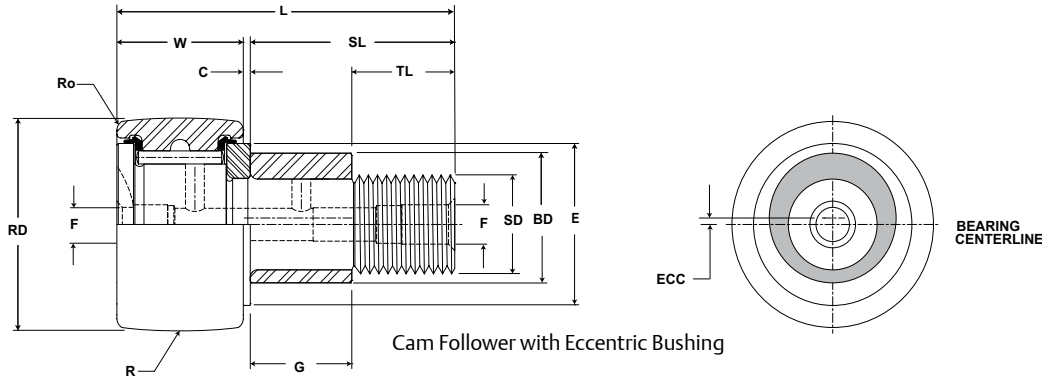

## CF, CFE, CFH

Part No.		HC	HD	F	E	Ro	HBD		Thread Type	Clamping Torque	Limiting Speed (Grease)	WT			
W/O Seals	With LUBRI-DISC Seals	Hole Center	Radial Hole Diameter	Axial Hole Dia or Fitting	Min Boss Diameter	Outer Corner	Housing Bore Diameter								
		inch mm			inch mm		inch mm								
		(Ref)	(Ref)	(Ref)	(Ref)	(Ref)	Nom.	Tol.					in-lb Nm	RPM	lb kg
CF 1 3/4	CF 1 3/4 S	.4375 11	.125 3	.1875 5	1.250 31.75	.063 1.59	.7503 19.058	+.0002/- .0003 +.0005/- .0008	3/4-16	1,250 141	2,200	.84 .38			
CF 1 3/4 B	CF 1 3/4 SB					N/A									
CCF 1 3/4	CCF 1 3/4 S														
CCF 1 3/4 B	CCF 1 3/4 SB														
CFE 1 3/4	CFE 1 3/4 S	.4375 11	.125 3	.1875 5	1.250 31.75	.063 1.59	1.003 25.47	+.001/- .001 +.025/- .025	3/4-16	1,250 141	2,200	.84 .38			
CFE 1 3/4 B	CFE 1 3/4 SB					N/A									
CCFE 1 3/4	CCFE 1 3/4 S														
CCFE 1 3/4 B	CCFE 1 3/4 SB														
CFH 1 3/4	CFH 1 3/4 S	.4375 11	.125 3	.1875 5	1.250 31.75	.063 1.59	1.0003 25.408	+.0002/- .0003 +.0005/- .0008	1-14	2,250 254	2,200	1.00 .45			
CFH 1 3/4 B	CFH 1 3/4 SB					N/A									
CCFH 1 3/4	CCFH 1 3/4 S														
CCFH 1 3/4 B	CCFH 1 3/4 SB														
CF 1 7/8	CF 1 7/8 S	.4375 11	.125 3	.1875 5	1.250 31.75	.063 1.59	.7503 19.058	+.0002/- .0003 +.0005/- .0008	3/4-16	1,250 141	2,000	.95 .43			
CF 1 7/8 B	CF 1 7/8 SB					N/A									
CCF 1 7/8	CCF 1 7/8 S														
CCF 1 7/8 B	CCF 1 7/8 SB														
CFE 1 7/8	CFE 1 7/8 S	.4375 11	.125 3	.1875 5	1.250 31.75	.063 1.59	1.003 25.47	+.001/- .001 +.025/- .025	3/4-16	1,250 141	2,000	.95 .43			
CFE 1 7/8 B	CFE 1 7/8 SB					N/A									
CCFE 1 7/8	CCFE 1 7/8 S														
CCFE 1 7/8 B	CCFE 1 7/8 SB														
CFH 1 7/8	CFH 1 7/8 S	.4375 11	.125 3	.1875 5	1.250 31.75	.063 1.59	1.0003 25.408	+.0002/- .0003 +.0005/- .0008	1-14	2,250 254	2,000	1.15 .52			
CFH 1 7/8 B	CFH 1 7/8 SB					N/A									
CCFH 1 7/8	CCFH 1 7/8 S														
CCFH 1 7/8 B	CCFH 1 7/8 SB														

For positive clamping, use housing thickness equal to G dimension  $\pm .010$ .  
Clamping torque is based on dry threads. If threads are lubricated, use half of value shown.  
Hex wrench size for "Broached" version is located in the wrench size chart on page B-156.

# MCGILL® Inch Cam Follower Bearings



- Basic Construction Type:** Stud Type Crowned / Cylindrical Outside Diameter
- Rolling Elements:** Full Complement Needle Roller
- Bearing Material:** Bearing Quality Steel
- Seal Type:** LUBRI-DISC®
- Lubrication:** Lithium Soap Grease NLGI #2
- System Configuration:** Concentric / Eccentric / Heavy Stud
- Mounting Feature:** Slot / Hex Hole

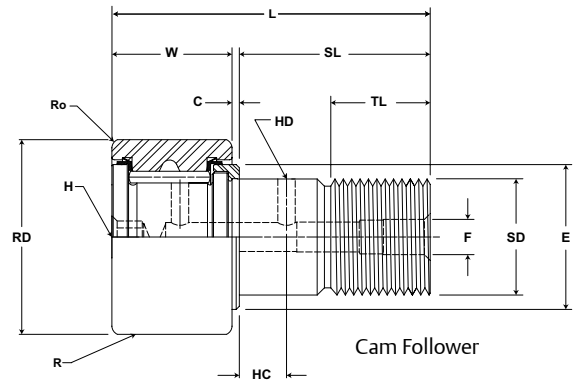

## CF, CFE, CFH

Part No.		RD		W		SD		SL	C	TL	L	R	ECC	G	BD	Track Roller Dynamic Rating	Track Roller Static Rating	
W/O Seals	With LUBRI-DISC Seals	Roller Diameter		Roller Width		Stud Diameter		Stud Length	Endplate Extension	Min Thread Length	Length Overall	Crown Prefix CCF-XX	Eccentric Base Modifier CFE-XX					
		inch mm		inch mm		inch mm		inch mm		inch mm		inch mm		inch mm				
		Nom.	Tol.	Nom.	Tol.	Nom.	Tol.	(Ref)	(Ref)	(Ref)	(Ref)	Radius (Ref)	(Ref)	+0/-0.010	±.001			Ib/N
CF 2	CF 2 S											Cylindrical	N/A	N/A	N/A	8,090 35,984	10,570 47,015	
CF 2 B	CF 2 SB	2.000	+0/-0.001	1.250	+0 / -0.005	.875	+0.01/-0	2.00	.031	1.00	3.28	24 610						
CCF 2	CCF 2 S	50.80	+0/-0.03	31.75	+0 / -0.13	22.23	+0.03/-0	50.8	.8	25.4	83.3							
CCF 2 B	CCF 2 SB																	
CFE 2	CFE 2 S											Cylindrical	.030	1.000	1.187	8,090 35,984	21,140 94,031	
CFE 2 B	CFE 2 SB	2.000	+0/-0.001	1.250	+0 / -0.005	.875	+0.01/-0	2.00	.031	1.00	3.28	24 610						
CCFE 2	CCFE 2 S	50.80	+0/-0.03	31.75	+0 / -0.13	22.23	+0.03/-0	50.8	.8	25.4	83.3							
CCFE 2 B	CCFE 2 SB																	
CFH 2	CFH 2 S											Cylindrical	N/A	N/A	N/A	8,090 35,984	21,140 94,031	
CFH 2 B	CFH 2 SB	2.000	+0/-0.001	1.250	+0 / -0.005	1.125	+0.01/-0	2.00	.031	1.00	3.28	24 610						
CCFH 2	CCFH 2 S	50.80	+0/-0.03	31.75	+0 / -0.13	28.58	+0.03/-0	50.8	.8	25.4	83.3							
CCFH 2 B	CCFH 2 SB																	
CF 2 1/4	CF 2 1/4 S											Cylindrical	N/A	N/A	N/A	8,090 35,984	10,570 47,015	
CF 2 1/4 B	CF 2 1/4 SB	2.250	+0/-0.001	1.250	+0 / -0.005	.875	+0.01/-0	2.00	.031	1.00	3.28	24 610						
CCF 2 1/4	CCF 2 1/4 S	57.15	+0/-0.03	31.75	+0 / -0.13	22.23	+0.03/-0	50.8	.8	25.4	83.3							
CCF 2 1/4 B	CCF 2 1/4 SB																	
CFE 2 1/4	CFE 2 1/4 S											Cylindrical	.030	1.000	1.187	8,090 35,984	21,140 94,031	
CFE 2 1/4 B	CFE 2 1/4 SB	2.250	+0/-0.001	1.250	+0 / -0.005	.875	+0.01/-0	2.00	.031	1.00	3.28	24 610						
CCFE 2 1/4	CCFE 2 1/4 S	57.15	+0/-0.03	31.75	+0 / -0.13	22.23	+0.03/-0	50.8	.8	25.4	83.3							
CCFE 2 1/4 B	CCFE 2 1/4 SB																	
CFH 2 1/4	CFH 2 1/4 S											Cylindrical	N/A	N/A	N/A	8,090 35,984	21,140 94,031	
CFH 2 1/4 B	CFH 2 1/4 SB	2.250	+0/-0.001	1.250	+0 / -0.005	1.125	+0.01/-0	2.00	.031	1.00	3.28	24 610						
CCFH 2 1/4	CCFH 2 1/4 S	57.15	+0/-0.03	31.75	+0 / -0.13	28.58	+0.03/-0	50.8	.8	25.4	83.3							
CCFH 2 1/4 B	CCFH 2 1/4 SB																	

Metric dimensions for reference only.  
Hex wrench size for "Broached" version is located in the wrench size chart on page B-156.

Not all parts are available from stock. Please contact customer service for availability (800) 626-2120.  
For more information on bearing capabilities outside of our standard offering, please contact Application Engineering (800) 626-2093.

# Inch Cam Follower Bearings **McGILL**

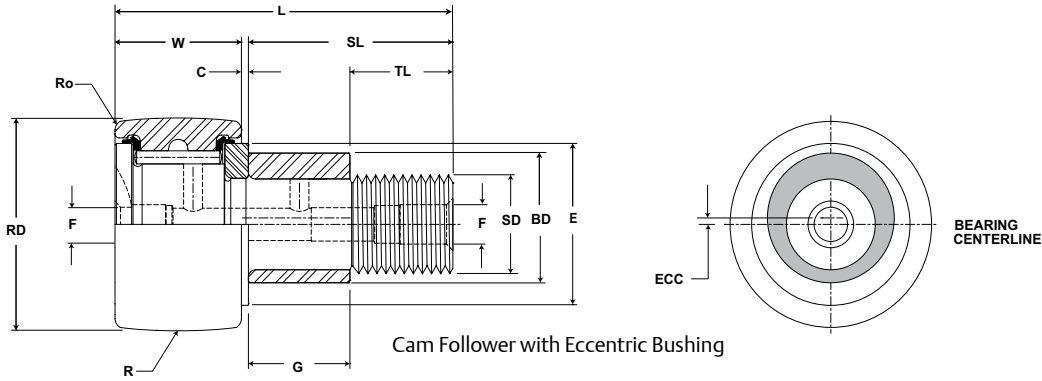

## CF, CFE, CFH

Part No.		HC	HD	F	E	Ro	HBD		Thread Type	Clamping Torque	Limiting Speed (Grease)	WT
W/O Seals	With LUBRI-DISC Seals	Hole Center	Radial Hole Diameter	Axial Hole Dia or Fitting	Min Boss Diameter	Outer Corner	Housing Bore Diameter					
		inch mm			inch mm		inch mm					
		(Ref)	(Ref)	(Ref)	(Ref)	(Ref)	Nom.	Tol.				
CF 2	CF 2 S	.50 13	.125 3	.1875 5	1.406 35.72	.094 2.38	.8753 22.233	+.0002/- .0003 +.0005/- .0008	7/8-14	1,500 170	1,400	1.36 .62
CF 2 B	CF 2 SB					N/A						
CCF 2	CCF 2 S					N/A						
CCF 2 B	CCF 2 SB					N/A						
CFE 2	CFE 2 S	.50 13	.125 3	.1875 5	1.406 35.72	.094 2.38	1.190 30.22	+.001/- .001 +.025/- .025	7/8-14	1,500 170	1,400	1.36 .62
CFE 2 B	CFE 2 SB					N/A						
CCFE 2	CCFE 2 S					N/A						
CCFE 2 B	CCFE 2 SB					N/A						
CFH 2	CFH 2 S	.50 13	.125 3	.1875 5	1.406 35.72	.094 2.38	1.1253 28.583	+.0002/- .0003 +.0005/- .0008	1 1/8-12	2,800 316	1,400	1.56 .71
CFH 2 B	CFH 2 SB					N/A						
CCFH 2	CCFH 2 S					N/A						
CCFH 2 B	CCFH 2 SB					N/A						
CF 2 1/4	CF 2 1/4 S	.50 13	.125 3	.1875 5	1.406 35.72	.094 2.38	.8753 22.233	+.0002/- .0003 +.0005/- .0008	7/8-14	1,500 170	1,300	1.65 .75
CF 2 1/4 B	CF 2 1/4 SB					N/A						
CCF 2 1/4	CCF 2 1/4 S					N/A						
CCF 2 1/4 B	CCF 2 1/4 SB					N/A						
CFE 2 1/4	CFE 2 1/4 S	.50 13	.125 3	.1875 5	1.406 35.72	.094 2.38	1.190 30.22	+.001/- .001 +.025/- .025	7/8-14	1,500 170	1,300	1.65 .75
CFE 2 1/4 B	CFE 2 1/4 SB					N/A						
CCFE 2 1/4	CCFE 2 1/4 S					N/A						
CCFE 2 1/4 B	CCFE 2 1/4 SB					N/A						
CFH 2 1/4	CFH 2 1/4 S	.50 13	.125 3	.1875 5	1.406 35.72	.094 2.38	1.1253 28.583	+.0002/- .0003 +.0005/- .0008	1 1/8-12	2,800 316	1,300	1.88 .85
CFH 2 1/4 B	CFH 2 1/4 SB					N/A						
CCFH 2 1/4	CCFH 2 1/4 S					N/A						
CCFH 2 1/4 B	CCFH 2 1/4 SB					N/A						

For positive clamping, use housing thickness equal to G dimension  $\pm .010$ ".  
Clamping torque is based on dry threads. If threads are lubricated, use half of value shown.  
Hex wrench size for "Broached" version is located in the wrench size chart on page B-156.

# MCGILL® Inch Cam Follower Bearings



- Basic Construction Type:** Stud Type Crowned / Cylindrical Outside Diameter
- Rolling Elements:** Full Complement Needle Roller
- Bearing Material:** Bearing Quality Steel
- Seal Type:** LUBRI-DISC®
- Lubrication:** Lithium Soap Grease NLGI #2
- System Configuration:** Concentric / Eccentric / Heavy Stud
- Mounting Feature:** Slot / Hex Hole

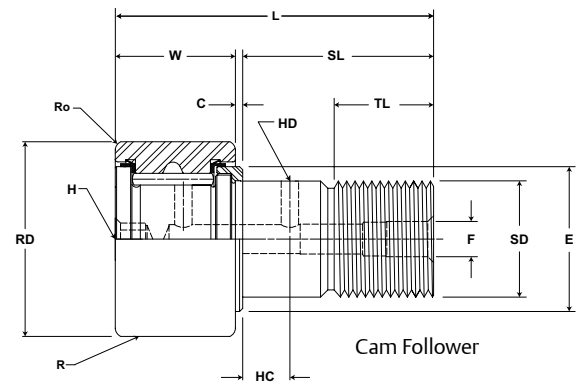

## CF, CFE, CFH

Part No.		RD		W		SD		SL	C	TL	L	R	ECC	G	BD	Track Roller Dynamic Rating	Track Roller Static Rating	
W/O Seals	With LUBRI-DISC Seals	Roller Diameter		Roller Width		Stud Diameter		Stud Length	Endplate Extension	Min Thread Length	Length Overall	Crown Prefix CCF-XX	Eccentric Base Modifier CFE-XX					
		inch mm		inch mm		inch mm		inch mm		inch mm		inch mm		inch mm				
		Nom.	Tol.	Nom.	Tol.	Nom.	Tol.	(Ref)	(Ref)	(Ref)	(Ref)	Radius (Ref)	(Ref)	+0/-0.010	±.001			lb/N
CF 2 1/2	CF 2 1/2 S	2.500 63.50	+0/-0.001 +0/-0.03	1.500 38.10	+0 / -0.005 +0 / -0.13	1.000 25.40	+0.01/-0 +0.03/-0	2.25 57.2	.031 .8	1.125 28.57	3.78 96.0	Cylindrical	N/A	N/A	N/A	11,720 52,131	16,450 73,170	
CF 2 1/2 B	CF 2 1/2 SB											30						
CCF 2 1/2	CCF 2 1/2 S											762						
CCF 2 1/2 B	CCF 2 1/2 SB																	
CFE 2 1/2	CFE 2 1/2 S	2.500 63.50	+0/-0.001 +0/-0.03	1.500 38.10	+0 / -0.005 +0 / -0.13	1.000 25.40	+0.01/-0 +0.03/-0	2.25 57.2	.031 .8	1.125 28.57	3.78 96.0	Cylindrical	.030 .76	1.125 28.58	1.375 34.93	11,720 52,131	16,450 73,170	
CFE 2 1/2 B	CFE 2 1/2 SB											30						
CCFE 2 1/2	CCFE 2 1/2 S											762						
CCFE 2 1/2 B	CCFE 2 1/2 SB																	
CFH 2 1/2	CFH 2 1/2 S	2.500 63.50	+0/-0.001 +0/-0.03	1.500 38.10	+0 / -0.005 +0 / -0.13	1.250 31.75	+0.01/-0 +0.03/-0	2.25 57.2	.031 .8	1.125 28.57	3.78 96.0	Cylindrical	N/A	N/A	N/A	11,720 52,131	32,900 146,339	
CFH 2 1/2 B	CFH 2 1/2 SB											30						
CCFH 2 1/2	CCFH 2 1/2 S											762						
CCFH 2 1/2 B	CCFH 2 1/2 SB																	
CF 2 3/4	CF 2 3/4 S	2.750 69.85	+0/-0.001 +0/-0.03	1.500 38.10	+0 / -0.005 +0 / -0.13	1.000 25.40	+0.01/-0 +0.03/-0	2.25 57.2	.031 .8	1.125 28.57	3.78 96.0	Cylindrical	N/A	N/A	N/A	11,720 52,131	16,450 73,170	
CF 2 3/4 B	CF 2 3/4 SB											30						
CCF 2 3/4	CCF 2 3/4 S											762						
CCF 2 3/4 B	CCF 2 3/4 SB																	
CFE 2 3/4	CFE 2 3/4 S	2.750 69.85	+0/-0.001 +0/-0.03	1.500 38.10	+0 / -0.005 +0 / -0.13	1.000 25.40	+0.01/-0 +0.03/-0	2.25 57.2	.031 .8	1.125 28.57	3.78 96.0	Cylindrical	.030 .76	1.125 28.58	1.375 34.93	11,720 52,131	16,450 73,170	
CFE 2 3/4 B	CFE 2 3/4 SB											30						
CCFE 2 3/4	CCFE 2 3/4 S											762						
CCFE 2 3/4 B	CCFE 2 3/4 SB																	
CFH 2 3/4	CFH 2 3/4 S	2.750 69.85	+0/-0.001 +0/-0.03	1.500 38.10	+0 / -0.005 +0 / -0.13	1.250 31.75	+0.01/-0 +0.03/-0	2.25 57.2	.031 .8	1.125 28.57	3.78 96.0	Cylindrical	N/A	N/A	N/A	11,720 52,131	32,900 146,339	
CFH 2 3/4 B	CFH 2 3/4 SB											30						
CCFH 2 3/4	CCFH 2 3/4 S											762						
CCFH 2 3/4 B	CCFH 2 3/4 SB																	

Metric dimensions for reference only.  
Hex wrench size for "Broached" version is located in the wrench size chart on page B-156.

Not all parts are available from stock. Please contact customer service for availability (800) 626-2120.  
For more information on bearing capabilities outside of our standard offering, please contact Application Engineering (800) 626-2093.

# Inch Cam Follower Bearings **MCGILL**

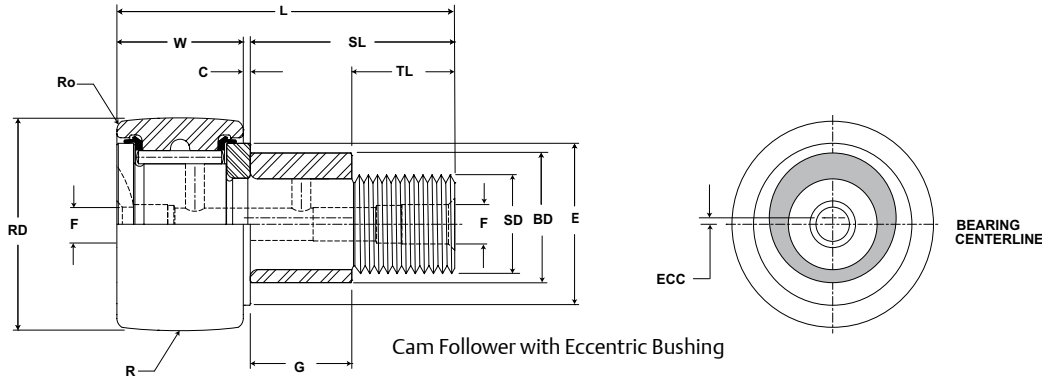

## CF, CFE, CFH

Part No.		HC	HD	F	E	Ro	HBD		Thread Type	Clamping Torque	Limiting Speed (Grease)	WT								
W/O Seals	With LUBRI-DISC Seals	Hole Center	Radial Hole Diameter	Axial Hole Dia or Fitting	Min Boss Diameter	Outer Corner	Housing Bore Diameter													
		inch mm			inch mm		inch mm													
		(Ref)	(Ref)	(Ref)	(Ref)	(Ref)	Nom.	Tol.					in-lb Nm	RPM	lb kg					
CF 2 1/2	CF 2 1/2 S	.5625 14	.125 3	.1875 5	1.688 42.86	.094 2.38	1.0003 25.408	+.0002/- .0003 +.0005/- .0008	1-14	2,250 254	1,100	2.50 1.13								
CF 2 1/2 B	CF 2 1/2 SB					N/A														
CCF 2 1/2	CCF 2 1/2 S					.5625 14	.125 3	.1875 5					1.688 42.86	.094 2.38	1.378 35.00	+.001/- .001 +.025/- .025				
CFE 2 1/2	CFE 2 1/2 S													N/A						
CFE 2 1/2 B	CFE 2 1/2 SB	.5625 14	.125 3	.1875 5	1.688 42.86				.094 2.38	1.2503 31.758	+.0002/- .0003 +.0005/- .0008	1 1/4-12		3,450 390	1,100	2.75 1.25				
CCF 2 1/2	CCF 2 1/2 S								N/A											
CCFH 2 1/2	CCFH 2 1/2 S					.5625 14	.125 3	.1875 5	1.688 42.86	.094 2.38	1.0003 25.408		+.0002/- .0003 +.0005/- .0008				1-14	2,250 254	1,050	2.93 1.33
CCFH 2 1/2 B	CCFH 2 1/2 SB									N/A										
CF 2 3/4	CF 2 3/4 S	.5625 14	.125 3	.1875 5	1.688 42.86					.094 2.38	1.378 35.00	+.001/- .001 +.025/- .025	1 1/4-12	3,450 390	1,050	3.19 1.47				
CF 2 3/4 B	CF 2 3/4 SB									N/A										
CCF 2 3/4	CCF 2 3/4 S					.5625 14	.125 3	.1875 5	1.688 42.86	.094 2.38	1.2503 31.758	+.0002/- .0003 +.0005/- .0008								
CCF 2 3/4 B	CCF 2 3/4 SB									N/A										

For positive clamping, use housing thickness equal to G dimension  $\pm .010$ ".  
Clamping torque is based on dry threads. If threads are lubricated, use half of value shown.  
Hex wrench size for "Broached" version is located in the wrench size chart on page B-156.



# MCGILL® Inch Cam Follower Bearings



- Basic Construction Type:** Stud Type Crowned / Cylindrical Outside Diameter
- Rolling Elements:** Full Complement Needle Roller
- Bearing Material:** Bearing Quality Steel
- Seal Type:** LUBRI-DISC®
- Lubrication:** Lithium Soap Grease NLGI #2
- System Configuration:** Concentric / Eccentric / Heavy Stud
- Mounting Feature:** Slot / Hex Hole

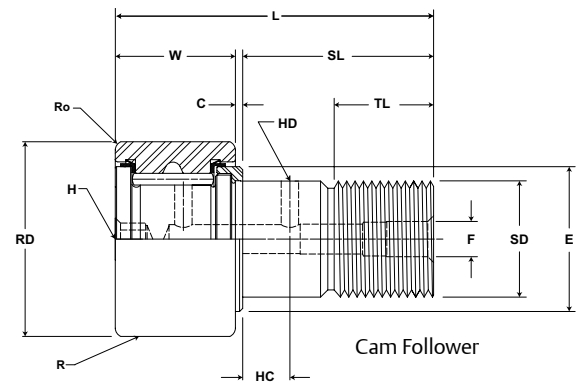

## CF, CFE, CFH

Part No.		RD		W		SD		SL	C	TL	L	R	ECC	G	BD	Track Roller Dynamic Rating	Track Roller Static Rating
W/O Seals	With LUBRI-DISC Seals	Roller Diameter		Roller Width		Stud Diameter		Stud Length	Endplate Extension	Min Thread Length	Length Overall	Crown Prefix CCF-XX	Eccentric Base Modifier CFE-XX				
		inch mm		inch mm		inch mm		inch mm		inch mm		inch mm	inch mm				
		Nom.	Tol.	Nom.	Tol.	Nom.	Tol.	(Ref)	(Ref)	(Ref)	(Ref)	Radius (Ref)	(Ref)	+0/-0.010	±.001		
CF 3	CF 3 S											Cylindrical	N/A	N/A	N/A	15,720 69,923	24,910 110,800 24,910 110,800
CF 3 B	CF 3 SB	3.000	+0/-0.001	1.750	+0 / - .005	1.250	+0.01/-0	2.50	.031	1.25	4.28	30 762					
CCF 3	CCF 3 S	76.20	+0/-0.03	44.45	+0 / - .13	31.75	+0.3/-0	63.5	.8	31.75	108.7						
CCF 3 B	CCF 3 SB																
CFE 3	CFE 3 S											Cylindrical	.060	1.250	1.750	15,720 69,923	24,910 110,800 24,910 110,800
CFE 3 B	CFE 3 SB	3.000	+0/-0.001	1.750	+0 / - .005	1.250	+0.01/-0	2.50	.031	1.25	4.28	30 762	.52	31.75	44.45		
CCFE 3	CCFE 3 S	76.20	+0/-0.03	44.45	+0 / - .13	31.75	+0.3/-0	63.5	.8	31.75	108.7						
CCFE 3 B	CCFE 3 SB																
CFH 3	CFH 3 S											Cylindrical	N/A	N/A	N/A	15,720 69,923	49,820 221,599
CFH 3 B	CFH 3 SB	3.000	+0/-0.001	1.750	+0 / - .005	1.500	+0.01/-0	2.50	.031	1.25	4.28	30 762					
CCFH 3	CCFH 3 S	76.20	+0/-0.03	44.45	+0 / - .13	38.10	+0.3/-0	63.5	.8	31.75	108.7						
CCFH 3 B	CCFH 3 SB																
CF 3 1/4	CF 3 1/4 S											Cylindrical	N/A	N/A	N/A	15,720 69,923	24,910 110,800
CF 3 1/4 B	CF 3 1/4 SB	3.250	+0/-0.001	1.750	+0 / - .005	1.250	+0.01/-0	2.50	.031	1.25	4.28	30 762					
CCF 3 1/4	CCF 3 1/4 S	82.55	+0/-0.03	44.45	+0 / - .13	31.75	+0.3/-0	63.5	.8	31.75	108.7						
CCF 3 1/4 B	CCF 3 1/4 SB																
CFE 3 1/4	CFE 3 1/4 S											Cylindrical	.060	1.250	1.750	15,720 69,923	24,910 110,800
CFE 3 1/4 B	CFE 3 1/4 SB	3.250	+0/-0.001	1.750	+0 / - .005	1.250	+0.01/-0	2.50	.031	1.25	4.28	30 762	.52	31.75	44.45		
CCFE 3 1/4	CCFE 3 1/4 S	82.55	+0/-0.03	44.45	+0 / - .13	31.75	+0.3/-0	63.5	.8	31.75	108.7						
CCFE 3 1/4 B	CCFE 3 1/4 SB																
CFH 3 1/4	CFH 3 1/4 S											Cylindrical	N/A	N/A	N/A	15,720 69,923	49,820 221,599
CFH 3 1/4 B	CFH 3 1/4 SB	3.250	+0/-0.001	1.750	+0 / - .005	1.500	+0.01/-0	2.50	.031	1.25	4.28	30 762					
CCFH 3 1/4	CCFH 3 1/4 S	82.55	+0/-0.03	44.45	+0 / - .13	38.10	+0.3/-0	63.5	.8	31.75	108.7						
CCFH 3 1/4 B	CCFH 3 1/4 SB																

Metric dimensions for reference only.  
Hex wrench size for "Broached" version is located in the wrench size chart on page B-156.

Not all parts are available from stock. Please contact customer service for availability (800) 626-2120.  
For more information on bearing capabilities outside of our standard offering, please contact Application Engineering (800) 626-2093.

# Inch Cam Follower Bearings **McGILL**

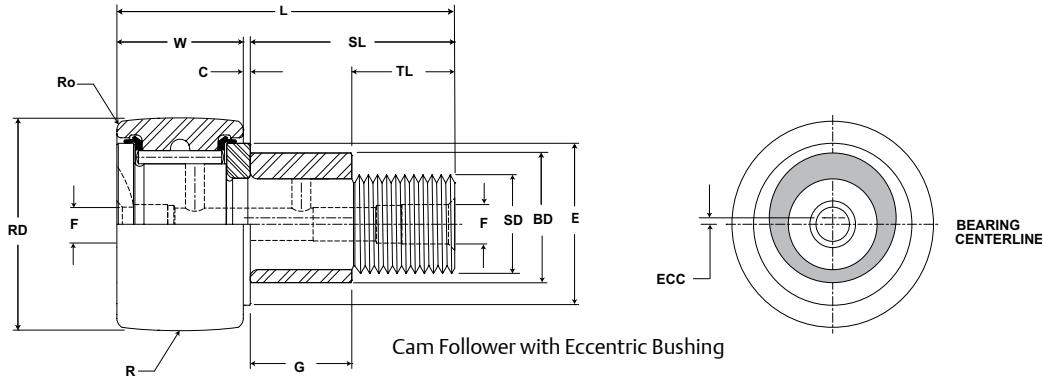

## CF, CFE, CFH

Part No.		HC	HD	F	E	Ro	HBD		Thread Type	Clamping Torque	Limiting Speed (Grease)	WT
W/O Seals	With LUBRI-DISC Seals	Hole Center	Radial Hole Diameter	Axial Hole Dia or Fitting	Min Boss Diameter	Outer Corner	Housing Bore Diameter					
		inch mm			inch mm		inch mm					
		(Ref)	(Ref)	(Ref)	(Ref)	(Ref)	Nom.	Tol.				
CF 3	CF 3 S	.625 16	.125 3	.25 * 6	2.125 53.98	.125 3.18	1.2503	+0.002/-0.003	1 1/4-12	3,450 390	950	4.20 1.91
CF 3 B	CF 3 SB					N/A	31.758	+0.005/-0.008				
CCF 3	CCF 3 S					N/A						
CCF 3 B	CCF 3 SB					N/A						
CFE 3	CFE 3 S	.625 16	.125 3	.25 * 6	2.125 53.98	.125 3.18	1.753	+0.01/-0.01	1 1/2-12	5,000 565	950	4.56 2.07
CFE 3 B	CFE 3 SB					N/A	38.108	+0.002/-0.003				
CCFE 3	CCFE 3 S					N/A		+0.005/-0.008				
CCFE 3 B	CCFE 3 SB					N/A						
CFH 3	CFH 3 S	.625 16	.125 3	.25 * 6	2.125 53.98	.125 3.18	1.5003	+0.002/-0.003	1 1/4-12	3,450 390	880	4.81 2.18
CFH 3 B	CFH 3 SB					N/A	31.758	+0.005/-0.008				
CCFH 3	CCFH 3 S					N/A						
CCFH 3 B	CCFH 3 SB					N/A						
CF 3 1/4	CF 3 1/4 S	.625 16	.125 3	.25 * 6	2.125 53.98	.125 3.18	1.2503	+0.002/-0.003	1 1/4-12	3,450 390	880	4.81 2.18
CF 3 1/4 B	CF 3 1/4 SB					N/A	31.758	+0.005/-0.008				
CCF 3 1/4	CCF 3 1/4 S					N/A						
CCF 3 1/4 B	CCF 3 1/4 SB					N/A						
CFE 3 1/4	CFE 3 1/4 S	.625 16	.125 3	.25 * 6	2.125 53.98	.125 3.18	1.753	+0.01/-0.01	1 1/2-12	5,000 565	880	5.19 2.35
CFE 3 1/4 B	CFE 3 1/4 SB					N/A	38.108	+0.002/-0.003				
CCFE 3 1/4	CCFE 3 1/4 S					N/A		+0.005/-0.008				
CCFE 3 1/4 B	CCFE 3 1/4 SB					N/A						
CFH 3 1/4	CFH 3 1/4 S	.625 16	.125 3	.25 * 6	2.125 53.98	.125 3.18	1.5003	+0.002/-0.003	1 1/2-12	5,000 565	880	5.19 2.35
CFH 3 1/4 B	CFH 3 1/4 SB					N/A	38.108	+0.005/-0.008				
CCFH 3 1/4	CCFH 3 1/4 S					N/A						
CCFH 3 1/4 B	CCFH 3 1/4 SB					N/A						

\* Lubrication hole (F) at bottom of hex hole and 1/4 inch straight drive fitting will ball check supplied but not installed.  
 For positive clamping, use housing thickness equal to G dimension  $\pm .010$ .  
 Clamping torque is based on dry threads. If threads are lubricated, use half of value shown.  
 Hex wrench size for "Broached" version is located in the wrench size chart on page B-156.

# McGILL® Inch Cam Follower Bearings



- Basic Construction Type:** Stud Type Crowned / Cylindrical Outside Diameter
- Rolling Elements:** Full Complement Needle Roller
- Bearing Material:** Bearing Quality Steel
- Seal Type:** LUBRI-DISC®
- Lubrication:** Lithium Soap Grease NLGI #2
- System Configuration:** Concentric / Eccentric / Heavy Stud
- Mounting Feature:** Slot / Hex Hole

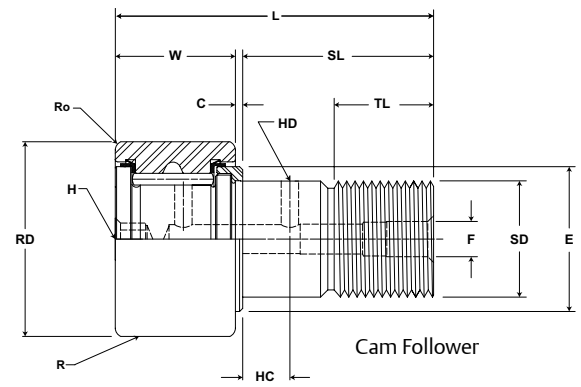

## CF, CFE, CFH

Part No.		RD		W		SD		SL	C	TL	L	R	ECC	G	BD	Track Roller Dynamic Rating	Track Roller Static Rating	
W/O Seals	With LUBRI-DISC Seals	Roller Diameter		Roller Width		Stud Diameter		Stud Length	Endplate Extension	Min Thread Length	Length Overall	Crown Prefix CCF-XX	Eccentric Base Modifier CFE-XX					
		inch mm		inch mm		inch mm		inch mm		inch mm		inch mm		inch mm				
		Nom.	Tol.	Nom.	Tol.	Nom.	Tol.	(Ref)	(Ref)	(Ref)	(Ref)	Radius (Ref)	(Ref)	+0/-0.010	±.001			lb/N
CF 3 1/2	CF 3 1/2 S	3.500 88.90	+0/-0.001 +0/-0.03	2.000 50.80	+0 / -0.005 +0 / -0.13	1.375 34.93	+0.001/-0 +0.03/-0	2.75 69.9	.031 .8	1.375 34.93	4.78 121.4	Cylindrical	N/A	N/A	N/A	22,800 101,414	31,625 140,668	
CF 3 1/2 B	CF 3 1/2 SB											30	.060 .52	1.375 34.93	1.812 46.02			
CCF 3 1/2	CCF 3 1/2 S											762						
CCF 3 1/2 B	CCF 3 1/2 SB											762						
CFE 3 1/2	CFE 3 1/2 S	3.500 88.90	+0/-0.001 +0/-0.03	2.000 50.80	+0 / -0.005 +0 / -0.13	1.375 34.93	+0.001/-0 +0.03/-0	2.75 69.9	.031 .8	1.375 34.93	4.78 121.4	Cylindrical	.060	1.375	1.812	22,800 101,414	63,250 281,336	
CFE 3 1/2 B	CFE 3 1/2 SB											30						
CCFE 3 1/2	CCFE 3 1/2 S											762						
CCFE 3 1/2 B	CCFE 3 1/2 SB											762						
CFH 3 1/2	CFH 3 1/2 S	3.500 88.90	+0/-0.001 +0/-0.03	2.000 50.80	+0 / -0.005 +0 / -0.13	1.750 44.45	+0.001/-0 +0.03/-0	2.75 69.9	.031 .8	1.375 34.93	4.78 121.4	Cylindrical	N/A	N/A	N/A	22,800 101,414	63,250 281,336	
CFH 3 1/2 B	CFH 3 1/2 SB											30						
CCFH 3 1/2	CCFH 3 1/2 S											762						
CCFH 3 1/2 B	CCFH 3 1/2 SB											762						
CF 4	CF 4 S	4.000 101.60	+0/-0.001 +0/-0.03	2.250 57.15	+0 / -0.005 +0 / -0.13	1.500 38.10	+0.001/-0 +0.03/-0	3.50 88.9	.031 .8	1.50 38.1	5.78 146.8	Cylindrical	N/A	N/A	N/A	22,800 101,414	44,770 199,137	
CF 4 B	CF 4 SB											30						
CCF 4	CCF 4 S											762						
CCF 4 B	CCF 4 SB											762						
CFE 4	CFE 4 S	4.000 101.60	+0/-0.001 +0/-0.03	2.250 57.15	+0 / -0.005 +0 / -0.13	1.500 38.10	+0.001/-0 +0.03/-0	3.50 88.9	.031 .8	1.50 38.1	5.78 146.8	Cylindrical	.060	2.000	2.000	29,985 133,373	89,540 398,274	
CFE 4 B	CFE 4 SB											30						
CCFE 4	CCFE 4 S											762						
CCFE 4 B	CCFE 4 SB											762						
CFH 4	CFH 4 S	4.000 101.60	+0/-0.001 +0/-0.03	2.250 57.15	+0 / -0.005 +0 / -0.13	2.000 50.80	+0.001/-0 +0.03/-0	3.50 88.9	.031 .8	1.50 38.1	5.78 146.8	Cylindrical	N/A	N/A	N/A	29,985 133,373	89,540 398,274	
CFH 4 B	CFH 4 SB											30						
CCFH 4	CCFH 4 S											762						
CCFH 4 B	CCFH 4 SB											762						

Metric dimensions for reference only.  
Hex wrench size for "Broached" version is located in the wrench size chart on page B-156.

Not all parts are available from stock. Please contact customer service for availability (800) 626-2120.  
For more information on bearing capabilities outside of our standard offering, please contact Application Engineering (800) 626-2093.

# Inch Cam Follower Bearings **McGILL**

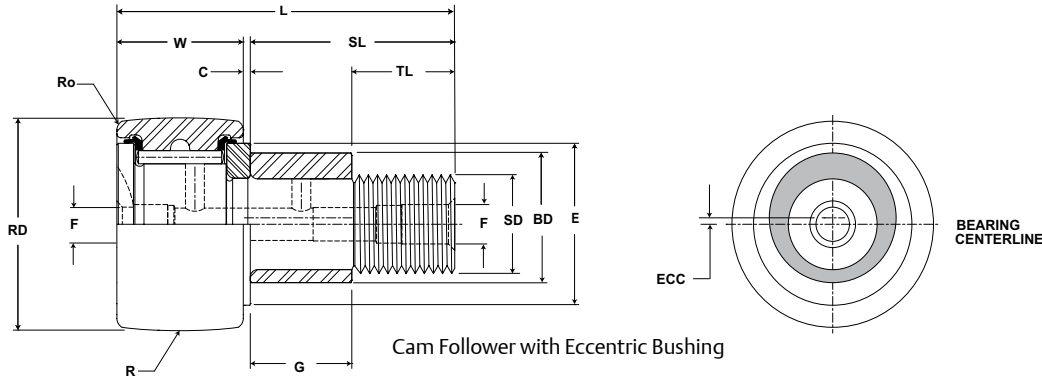

CF, CFE, CFH

Part No.		HC	HD	F	E	Ro	HBD		Thread Type	Clamping Torque	Limiting Speed (Grease)	WT
W/O Seals	With LUBRI-DISC Seals	Hole Center	Radial Hole Diameter	Axial Hole Dia or Fitting	Min Boss Diameter	Outer Corner	Housing Bore Diameter					
		inch mm			inch mm		inch mm					
		(Ref)	(Ref)	(Ref)	(Ref)	(Ref)	Nom.	Tol.				
CF 3 1/2	CF 3 1/2 S	.6875 17	.125 3	.25 * 6	2.438 61.91	.125 3.18	1.3753	+0.002/-0.003	1 3/8-12	4,200 475	820	6.42 2.91
CF 3 1/2 B	CF 3 1/2 SB					N/A	34.933	+0.005/-0.008				
CCF 3 1/2	CCF 3 1/2 S											
CCF 3 1/2 B	CCF 3 1/2 SB											
CFE 3 1/2	CFE 3 1/2 S	.6875 17	.125 3	.25 * 6	2.438 61.91	.125 3.18	1.815	+0.001/-0.001	1 3/4-12	5,000 565	820	7.01 3.18
CFE 3 1/2 B	CFE 3 1/2 SB					N/A	46.10	+0.025/-0.025				
CCFE 3 1/2	CCFE 3 1/2 S											
CCFE 3 1/2 B	CCFE 3 1/2 SB											
CFH 3 1/2	CFH 3 1/2 S	.6875 17	.125 3	.25 * 6	2.438 61.91	.125 3.18	1.7503	+0.002/-0.003	1 3/4-12	5,000 565	820	7.01 3.18
CFH 3 1/2 B	CFH 3 1/2 SB					N/A	44.458	+0.005/-0.008				
CCFH 3 1/2	CCFH 3 1/2 S											
CCFH 3 1/2 B	CCFH 3 1/2 SB											
CF 4	CF 4 S	.75 19	.125 3	.25 * 6	2.797 71.04	.125 3.18	1.5003	+0.002/-0.003	1 1/2-12	5,000 565	700	9.46 4.29
CF 4 B	CF 4 SB					N/A	38.108	+0.005/-0.008				
CCF 4	CCF 4 S											
CCF 4 B	CCF 4 SB											
CFE 4	CFE 4 S	.75 19	.125 3	.25 * 6	2.797 71.04	.125 3.18	2.002	+0.001/-0.001	2-12	5,000 565	700	10.83 4.91
CFE 4 B	CFE 4 SB					N/A	50.85	+0.025/-0.025				
CCFE 4	CCFE 4 S											
CCFE 4 B	CCFE 4 SB											
CFH 4	CFH 4 S	.75 19	.125 3	.25 * 6	2.797 71.04	.125 3.18	2.0003	+0.002/-0.003	2-12	5,000 565	700	10.83 4.91
CFH 4 B	CFH 4 SB					N/A	50.808	+0.005/-0.008				
CCFH 4	CCFH 4 S											
CCFH 4 B	CCFH 4 SB											

\* Lubrication hole (F) at bottom of hex hole and 1/4 inch straight drive fitting will ball check supplied but not installed.  
For positive clamping, use housing thickness equal to G dimension  $\pm .010$ ".  
Clamping torque is based on dry threads. If threads are lubricated, use half of value shown.  
Hex wrench size for "Broached" version is located in the wrench size chart on page B-156.

# MCGILL® Inch Cam Follower Bearings



- Basic Construction Type:** Stud Type Crowned / Cylindrical Outside Diameter
- Rolling Elements:** Full Complement Needle Roller
- Bearing Material:** Bearing Quality Steel
- Seal Type:** LUBRI-DISC®
- Lubrication:** Lithium Soap Grease NLGI #2
- System Configuration:** Concentric / Eccentric / Heavy Stud
- Mounting Feature:** Slot / Hex Hole

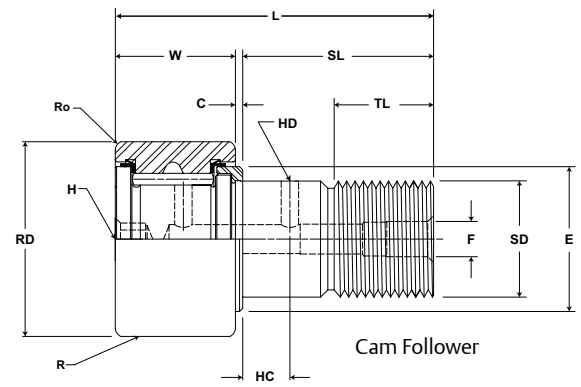

## CF, CFE, CFH

Part No.		RD		W		SD		SL	C	TL	L	R	ECC	G	BD	Track Roller Dynamic Rating	Track Roller Static Rating
W/O Seals	With LUBRI-DISC Seals	Roller Diameter		Roller Width		Stud Diameter		Stud Length	Endplate Extension	Min Thread Length	Length Overall	Crown Prefix CCF-XX	Eccentric Base Modifier CFE-XX				
		inch mm		inch mm		inch mm		inch mm	inch mm	inch mm	inch mm	inch mm	inch mm				
		Nom.	Tol.	Nom.	Tol.	Nom.	Tol.	(Ref)	(Ref)	(Ref)	(Ref)	Radius (Ref)	(Ref)	+0/-0.010	±.001	lb/N	
-	CF 5 SB	5.000	+0/-0.001	2.750	+0 / -0.005	2.000	+0.01/-0	5.06	.062	2.563	7.88	Cylindrical	N/A	N/A	N/A	46,575	67,950
	CCF 5 SB	127.00	+0/-0.03	69.85	+0 / -0.13	50.80	+0.03/-0	128.6	1.57	65.1	200.0	48 1,219					
	CFH 5 SB	5.000	+0/-0.001	2.750	+0 / -0.005	2.500	+0.01/-0	5.06	.062	2.563	7.88	Cylindrical	N/A	N/A	N/A	46,575	135,900
	CCFH 5 SB	127.00	+0/-0.03	69.85	+0 / -0.13	63.50	+0.03/-0	128.6	1.57	65.1	200.0	48 1,219					
-	CF 6 SB	6.000	+0/-0.001	3.250	+0 / -0.005	2.500	+0.01/-0	6.00	.062	3.00	9.31	Cylindrical	N/A	N/A	N/A	60,000	80,450
	CCF 6 SB	152.40	+0/-0.03	82.55	+0 / -0.13	63.50	+0.03/-0	152.4	1.57	76.2	236.5	56 1,422					
	CFH 6 SB	6.000	+0/-0.001	3.250	+0 / -0.005	2.500	+0.01/-0	6.00	.062	3.00	9.31	Cylindrical	N/A	N/A	N/A	60,000	160,900
	CCFH 6 SB	152.40	+0/-0.03	82.55	+0 / -0.13	63.50	+0.03/-0	152.4	1.57	76.2	236.5	56 1,422					
-	CF 7 SB	7.000	+0/-0.001	3.750	+0 / -0.005	3.000	+0.01/-0	7.69	.062	4.125	11.50	Cylindrical	N/A	N/A	N/A	75,380	106,930
	CCF 7 SB	177.80	+0/-0.03	95.25	+0 / -0.13	76.20	+0.03/-0	195.3	1.57	104.77	292.1	60 1,524					
	CFH 7 SB	7.000	+0/-0.001	3.750	+0 / -0.005	3.000	+0.01/-0	7.69	.062	4.125	11.50	Cylindrical	N/A	N/A	N/A	75,380	213,860
	CCFH 7 SB	177.80	+0/-0.03	95.25	+0 / -0.13	76.20	+0.03/-0	195.3	1.57	104.77	292.1	60 1,524					
-	CF 8 SB	8.000	*	4.250	*	3.250	+0.01/-0	8.50	.125	4.25	12.81	Cylindrical	N/A	N/A	N/A	92,200	144,100
	CCF 8 SB	203.20		107.95		82.55	+0.03/-0	215.9	3.175	107.95	325.4	40 1,016					
-	CF 9 SB	9.000	*	4.750	*	3.750	+0.01/-0	9.50	.125	4.75	14.31	Cylindrical	N/A	N/A	N/A	113,260	183,430
	CCF 9 SB	228.60		120.65		95.25	+0.03/-0	241.3	3.175	120.65	363.5	40 1,016					
-	CF 10 SB	10.000	*	5.250	*	4.250	+0.01/-0	10.00	.125	4.75	15.31	Cylindrical	N/A	N/A	N/A	131,545	215,565
	CCF 10 SB	254.00		133.35		107.95	+0.03/-0	254.0	3.175	120.65	388.9	40 1,016					

Metric dimensions for reference only.  
 \*Standard tolerances do not apply. Consult Application Engineering.  
 Hex wrench size for "Broached" version is located in the wrench size chart on page B-156.

Not all parts are available from stock. Please contact customer service for availability (800) 626-2120.  
 For more information on bearing capabilities outside of our standard offering, please contact Application Engineering (800) 626-2093.

# Inch Cam Follower Bearings **MCGILL**

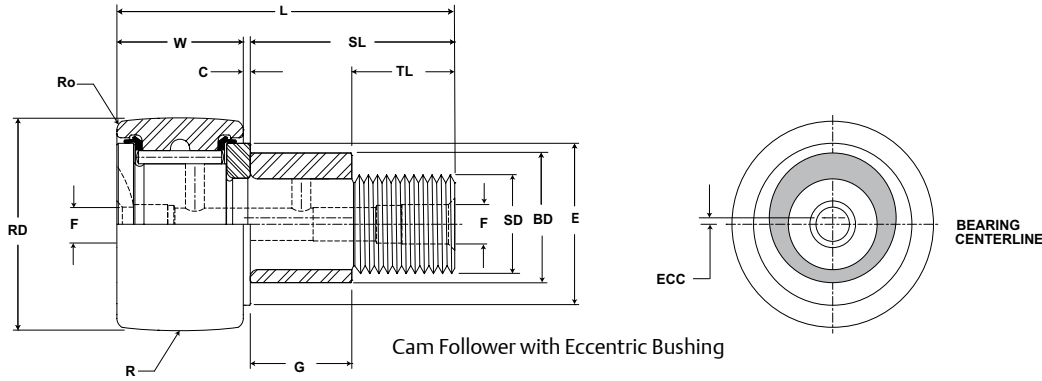

CF, CFE, CFH

Part No.		HC	HD	F	E	Ro	HBD		Thread Type	Clamping Torque	Limiting Speed (Grease)	WT
W/O Seals	With LUBRI-DISC Seals	Hole Center	Radial Hole Diameter	Axial Hole Dia or Fitting	Min Boss Diameter	Outer Corner	Housing Bore Diameter					
		inch mm		inch mm		inch mm						
		(Ref)	(Ref)	(Ref)	(Ref)	Nom.	Tol.	in-lb Nm				
-	CF 5 S	.875	.1875	1/4" NPT	3.563	.125	2.0003	+0.002/-0.003	2-12	5,000	575	19.60
	CCF 5 S	22	5		90.49	3.18	50.808	+0.005/-0.008				
	CFH 5 S	.875	.1875	1/4" NPT	3.563	.125	2.5030	+0.002/-0.003	2 1/2-12	5,000	575	22.10
	CCFH 5 S	22	5		90.49	3.18	63.576	+0.005/-0.008				
-	CF 6 S	1.00	.1875	1/4" NPT	4.469	.125	2.5030	+0.002/-0.003	2 1/2-12	5,000	475	32.73
	CCF 6 S	25	5		113.51	3.18	63.576	+0.005/-0.008				
	CFH 6 S	1.00	.1875	1/4" NPT	4.469	.125	3.0003	+0.002/-0.003	3-12	5,000	475	36.41
	CCFH 6 S	25	5		113.51	3.18	76.208	+0.005/-0.008				
-	CF 7 S	1.25	.1875	1/4" NPT	5.188	.125	3.0003	+0.002/-0.003	3-12	5,000	400	54.73
	CCF 7 S	32	5		131.76	3.18	76.208	+0.005/-0.008				
	CFH 7 S	1.25	.1875	1/4" NPT	5.188	.125	3.5003	+0.002/-0.003	3 1/2-4	5,000	400	68.03
	CCFH 7 S	32	5		131.76	3.18	88.908	+0.005/-0.008				
-	CF 8 S	-	-	1/4" NPT	4.375	.219	3.2503	+0.002/-0.003	3 1/4-4	5,000	350	79.80
	CCF 8 S	-	-		111.13	5.56	82.558	+0.005/-0.008				
-	CF 9 S	-	-	1/4" NPT	5.063	.250	3.7503	+0.002/-0.003	3 1/2-4	5,000	300	111.60
	CCF 9 S	-	-		128.59	6.35	95.258	+0.005/-0.008				
-	CF 10 S	-	-	1/4" NPT	5.469	.281	4.2503	+0.002/-0.003	3 1/2-4	5,000	275	148.20
	CCF 10 S	-	-		138.91	7.14	107.958	+0.005/-0.008				

For positive clamping, use housing thickness equal to G dimension = .010".  
Clamping torque based on dry threads. For wet (lubricated) threads, use half of value shown.  
Hex wrench size for "Broached" version is located in the wrench size chart on page B-156.

# MCGILL® Inch Cam Follower Bearings



**Basic Construction Type:** Yoke Type Crowned/  
Cylindrical Outside Diameter

**Rolling Elements:** Full Complement/Needle  
Roller

**Bearing Material:** Bearing Quality Steel

**Seal Type:** LUBRI-DISC®

**Lubrication:** Lithium Soap Grease NLGI #2

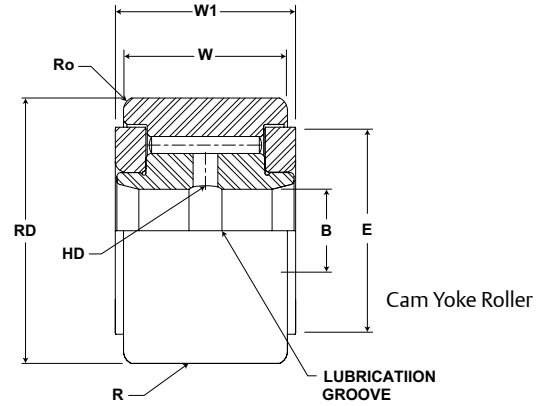

## CYR

Part No.		RD		W		B		W1		R	Track Roller Dynamic Rating	Track Roller Static Rating
W/O Seals	With LUBRI-DISC Seals	Roller Diameter		Roller Width		Bore Diameter		Overall Width		Crown		
		inch mm		inch mm		inch mm		inch mm		Prefix CCYR-XX		
		Nom.	Tol.	Nom.	Tol.	Nom.	Tol.	Nom.	Tol.	inch mm Radius	lb/N	lb/N
CYR 3/4	CYR 3/4 S	.750	+0/-0.001	.500	+0/-0.005	.250	+0.002/-0.0004	.5625	+0.005/-0.01	Cylindrical	1,660 7,384	4,130 18,370
	CCYR 3/4 S	19.05	+0/-0.03	12.70	+0/-0.13	6.35	+0.0005/-0.0010	14.28	+0.13/-0.25	10 254		
CYR 7/8	CYR 7/8 S	.875	+0/-0.001	.500	+0/-0.005	.250	+0.002/-0.0004	.5625	+0.005/-0.01	Cylindrical	1,660 7,384	4,130 18,370
	CCYR 7/8 S	22.23	+0/-0.03	12.70	+0/-0.13	6.35	+0.0005/-0.0010	14.28	+0.13/-0.25	10 254		
CYR 1	CYR 1 S	1.000	+0/-0.001	.625	+0/-0.005	.3125	+0.002/-0.0004	.6875	+0.005/-0.01	Cylindrical	2,225 9,897	6,120 27,222
	CCYR 1 S	25.40	+0/-0.03	15.88	+0/-0.13	7.94	+0.0005/-0.0010	17.46	+0.13/-0.25	12 305		
CYR 1 1/8	CYR 1 1/8 S	1.125	+0/-0.001	.625	+0/-0.005	.3125	+0.002/-0.0004	.6875	+0.005/-0.01	Cylindrical	2,225 9,897	6,120 27,222
	CCYR 1 1/8 S	28.58	+0/-0.03	15.88	+0/-0.13	7.94	+0.0005/-0.0010	17.46	+0.13/-0.25	12 305		
CYR 1 1/4	CYR 1 1/4 S	1.250	+0/-0.001	.750	+0/-0.005	.375	+0.002/-0.0004	.8125	+0.005/-0.01	Cylindrical	3,930 17,481	8,500 37,808
	CCYR 1 1/4 S	31.75	+0/-0.03	19.05	+0/-0.13	9.53	+0.0005/-0.0010	20.64	+0.13/-0.25	14 356		
CYR 1 3/8	CYR 1 3/8 S	1.375	+0/-0.001	.750	+0/-0.005	.375	+0.002/-0.0004	.8125	+0.005/-0.01	Cylindrical	3,930 17,481	8,500 37,808
	CCYR 1 3/8 S	34.93	+0/-0.03	19.05	+0/-0.13	9.53	+0.0005/-0.0010	20.64	+0.13/-0.25	14 356		
CYR 1 1/2	CYR 1 1/2 S	1.500	+0/-0.001	.875	+0/-0.005	.4375	+0.002/-0.0004	.9375	+0.005/-0.01	Cylindrical	4,840 21,528	11,280 50,173
	CCYR 1 1/2 S	38.10	+0/-0.03	22.23	+0/-0.13	11.11	+0.0005/-0.0010	23.81	+0.13/-0.25	20 508		
CYR 1 5/8	CYR 1 5/8 S	1.625	+0/-0.001	.875	+0/-0.005	.4375	+0.002/-0.0004	.9375	+0.005/-0.01	Cylindrical	4,840 21,528	11,280 50,173
	CCYR 1 5/8 S	41.28	+0/-0.03	22.23	+0/-0.13	11.11	+0.0005/-0.0010	23.81	+0.13/-0.25	20 508		
CYR 1 3/4	CYR 1 3/4 S	1.750	+0/-0.001	1.000	+0/-0.005	.500	+0.002/-0.0004	1.0625	+0.005/-0.01	Cylindrical	6,385 28,400	115,840 515,256
	CCYR 1 3/4 S	44.45	+0/-0.03	25.40	+0/-0.13	12.70	+0.0005/-0.0010	26.98	+0.13/-0.25	20 508		

Metric dimensions for reference only.  
 Not all parts are available from stock. Please contact customer service for availability (800) 626-2120.  
 For more information on bearing capabilities outside of our standard offering, please contact Application Engineering (800) 626-2093.

# Inch Cam Follower Bearings **McGILL**

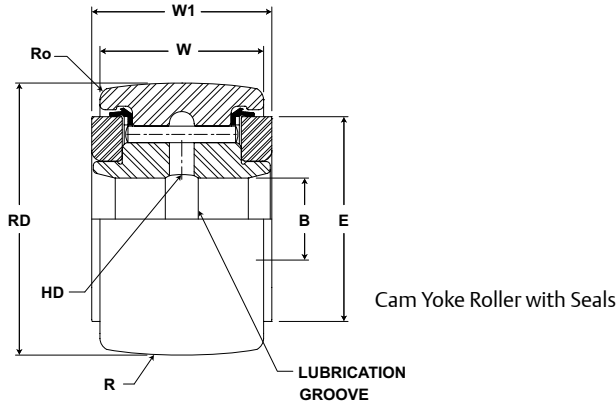

CYR

Part No.		HD	E	Ro	Recommended Shaft Diameters						Limiting Speed	WT
W/O Seals	With LUBRI-DISC Seals	Hole Diameter	Min. Clamping Diameter	Outer Corner	Push Fit		Drive Fit		Press Fit		RPM	Bearing Weight
		inch mm			inch mm		inch mm		inch mm			
		(Ref)	(Ref)	(Ref)	Nom	Tol	Nom	Tol	Nom	Tol		
CYR 3/4	CYR 3/4 S	.09 2.4	.61 15.5	.02 .4	.2495 6.337	±.0002 ±.005	.2501 6.353	±.0002 ±.005	.2503 6.357	±.0002 ±.005	6,400	.06 .03
	CCYR 3/4 S			N/A								
CYR 7/8	CYR 7/8 S	.09 2.4	.61 15.5	.02 .4	.2495 6.337	±.0002 ±.005	.2501 6.353	±.0002 ±.005	.2503 6.357	±.0002 ±.005	5,400	.08 .04
	CCYR 7/8 S			N/A								
CYR 1	CYR 1 S	.09 2.4	.78 19.8	.03 .8	.3120 7.925	±.0002 ±.005	.3126 7.940	±.0002 ±.005	.3128 7.945	±.0002 ±.005	4,800	.15 .07
	CCYR 1 S			N/A								
CYR 1 1/8	CYR 1 1/8 S	.09 2.4	.78 19.8	.03 .8	.3120 7.925	±.0002 ±.005	.3126 7.940	±.0002 ±.005	.3128 7.945	±.0002 ±.005	3,400	.17 .08
	CCYR 1 1/8 S			N/A								
CYR 1 1/4	CYR 1 1/4 S	.09 2.4	.98 25.0	.03 .8	.3745 9.512	±.0002 ±.005	.3751 9.527	±.0002 ±.005	.3753 9.532	±.0002 ±.005	3,100	.24 .11
	CCYR 1 1/4 S			N/A								
CYR 1 3/8	CYR 1 3/8 S	.09 2.4	.98 25.0	.05 1.2	.3745 9.512	±.0002 ±.005	.3751 9.527	±.0002 ±.005	.3753 9.532	±.0002 ±.005	2,800	.30 .14
	CCYR 1 3/8 S			N/A								
CYR 1 1/2	CYR 1 1/2 S	.09 2.4	1.09 27.8	.06 1.6	.4370 11.100	±.0002 ±.005	.4376 11.115	±.0002 ±.005	.4378 11.120	±.0002 ±.005	2,500	.41 .19
	CCYR 1 1/2 S			N/A								
CYR 1 5/8	CYR 1 5/8 S	.09 2.4	1.09 27.8	.06 1.6	.4370 11.100	±.0002 ±.005	.4376 11.115	±.0002 ±.005	.4378 11.120	±.0002 ±.005	2,350	.50 .23
	CCYR 1 5/8 S			N/A								
CYR 1 3/4	CYR 1 3/4 S	.09 2.4	1.25 31.8	.06 1.6	.4995 12.687	±.0002 ±.005	.5001 12.703	±.0002 ±.005	.5005 12.713	±.0002 ±.005	2,200	.64 .29
	CCYR 1 3/4 S			N/A								



# MCGILL® Inch Cam Follower Bearings



**Basic Construction Type:** Yoke Type Crowned/  
Cylindrical Outside Diameter

**Rolling Elements:** Full Complement/Needle  
Roller

**Bearing Material:** Bearing Quality Steel

**Seal Type:** LUBRI-DISC®

**Lubrication:** Lithium Soap Grease NLGI #2

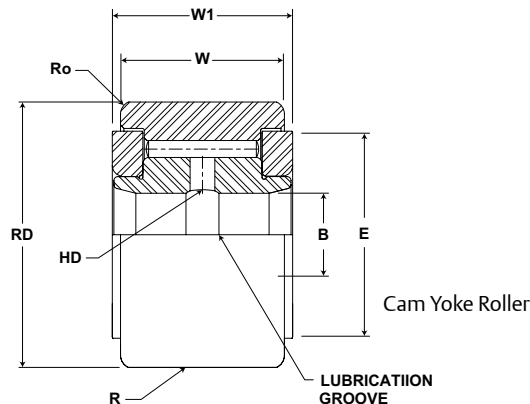

## CYR

Part No.		RD		W		B		W1		R	Track Roller Dynamic Rating	Track Roller Static Rating
W/O Seals	With LUBRI-DISC Seals	Roller Diameter		Roller Width		Bore Diameter		Overall Width		Crown		
		inch mm		inch mm		inch mm		inch mm		Prefix CCYR-XX		
		Nom.	Tol.	Nom.	Tol.	Nom.	Tol.	Nom.	Tol.	inch mm Radius		
CYR 1 7/8	CYR 1 7/8 S	1.875 47.63	+0/-0.001 +0/-0.03	1.000 25.40	+0/-0.005 +0/-0.13	.500 12.70	+0.001/-0.0005 +0.0003/-0.0013	1.0625 26.98	+0.005/-0.01 +0.13/-0.25	Cylindrical	6,385 28,400	115,840 515,256
	CCYR 1 7/8 S									20 508		
CYR 2	CYR 2 S	2.000 50.80	+0/-0.001 +0/-0.03	1.250 31.75	+0/-0.005 +0/-0.13	.625 15.88	+0.001/-0.0005 +0.0003/-0.0013	1.3125 33.34	+0.005/-0.01 +0.13/-0.25	Cylindrical	8,090 35,984	21,140 94,031
	CCYR 2 S									24 610		
CYR 2 1/4	CYR 2 1/4 S	2.250 57.15	+0/-0.001 +0/-0.03	1.250 31.75	+0/-0.005 +0/-0.13	.625 15.88	+0.001/-0.0005 +0.0003/-0.0013	1.3125 33.34	+0.005/-0.01 +0.13/-0.25	Cylindrical	8,090 35,984	21,140 94,031
	CCYR 2 1/4 S									24 610		
CYR 2 1/2	CYR 2 1/2 S	2.500 63.50	+0/-0.001 +0/-0.03	1.500 38.10	+0/-0.005 +0/-0.13	.750 19.05	+0.001/-0.0005 +0.0003/-0.0013	1.5625 39.69	+0.005/-0.01 +0.13/-0.25	Cylindrical	11,720 52,131	32,900 146,339
	CCYR 2 1/2 S									30 762		
CYR 2 3/4	CYR 2 3/4 S	2.750 69.85	+0/-0.001 +0/-0.03	1.500 38.10	+0/-0.005 +0/-0.13	.750 19.05	+0.001/-0.0005 +0.0003/-0.0013	1.5625 39.69	+0.005/-0.01 +0.13/-0.25	Cylindrical	11,720 52,131	32,900 146,339
	CCYR 2 3/4 S									30 762		
CYR 3	CYR 3 S	3.000 76.20	+0/-0.001 +0/-0.03	1.750 44.45	+0/-0.005 +0/-0.13	1.000 25.40	+0.001/-0.0005 +0.0003/-0.0013	1.8125 46.04	+0.005/-0.01 +0.13/-0.25	Cylindrical	15,720 69,923	49,820 221,599
	CCYR 3 S									30 762		
CYR 3 1/4	CYR 3 1/4 S	3.250 82.55	+0/-0.001 +0/-0.03	1.750 44.45	+0/-0.005 +0/-0.13	1.000 25.40	+0.001/-0.0005 +0.0003/-0.0013	1.8125 46.04	+0.005/-0.01 +0.13/-0.25	Cylindrical	15,720 69,923	49,820 221,599
	CCYR 3 1/4 S									30 762		
CYR 3 1/2	CYR 3 1/2 S	3.500 88.90	+0/-0.001 +0/-0.03	2.000 50.80	+0/-0.005 +0/-0.13	1.125 28.58	+0.001/-0.0005 +0.0003/-0.0013	2.0625 52.39	+0.005/-0.01 +0.13/-0.25	Cylindrical	22,800 101,414	63,250 281,336
	CCYR 3 1/2 S									30 762		
CYR 4	CYR 4 S	4.000 101.60	+0/-0.001 +0/-0.03	2.250 57.15	+0/-0.005 +0/-0.13	1.250 31.75	+0.001/-0.0005 +0.0003/-0.0013	2.3125 58.74	+0.005/-0.01 +0.13/-0.25	Cylindrical	29,985 133,373	89,540 398,274
	CCYR 4 S									30 762		

Metric dimensions for reference only.

Not all parts are available from stock. Please contact customer service for availability (800) 626-2120.

For more information on bearing capabilities outside of our standard offering, please contact Application Engineering (800) 626-2093.

# Inch Cam Follower Bearings **McGILL**

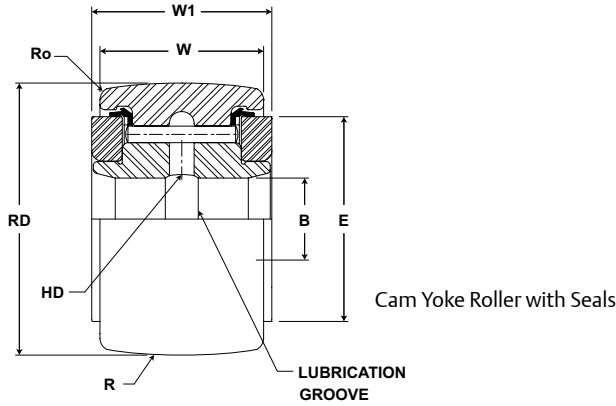

CYR

Part No.		HD	E	Ro	Recommended Shaft Diameters						Limiting Speed	WT
W/O Seals	With LUBRI-DISC Seals	Hole Diameter	Min. Clamping Diameter	Outer Corner	Push Fit		Drive Fit		Press Fit		RPM	Bearing Weight
		inch mm			inch mm		inch mm		inch mm			lb kg
		(Ref)	(Ref)	(Ref)	Nom	Tol	Nom	Tol	Nom	Tol		
CYR 1 7/8	CYR 1 7/8 S	.09 2.4	1.25 31.8	.06 1.6	.4995 12.687	±.0002 ±.005	.5001 12.703	±.0002 ±.005	.5005 12.713	±.0002 ±.005	2,000	.80 .36
	CCYR 1 7/8 S			N/A								
CYR 2	CYR 2 S	.13 3.2	1.41 35.7	.09 2.4	.6245 15.862	±.0002 ±.005	.6245 15.862	±.0002 ±.005	.6245 15.862	±.0002 ±.005	1,400	1.05 .48
	CCYR 2 S			N/A								
CYR 2 1/4	CYR 2 1/4 S	.13 3.2	1.41 35.7	.09 2.4	.6245 15.862	±.0002 ±.005	.6251 15.877	±.0002 ±.005	.6255 15.887	±.0002 ±.005	1,300	1.32 .59
	CCYR 2 1/4 S			N/A								
CYR 2 1/2	CYR 2 1/2 S	.13 3.2	1.69 42.9	.09 2.4	.7495 19.037	±.0002 ±.005	.7501 19.053	±.0002 ±.005	.75015 19.063	±.0002 ±.005	1,100	1.80 .82
	CCYR 2 1/2 S			N/A								
CYR 2 3/4	CYR 2 3/4 S	.13 3.2	1.69 42.9	.09 2.4	.7495 19.037	±.0002 ±.005	.7501 19.053	±.0002 ±.005	.75015 19.063	±.0002 ±.005	1,050	2.25 1.02
	CCYR 2 3/4 S			N/A								
CYR 3	CYR 3 S	.13 3.2	2.13 54.0	.13 3.2	.9994 25.385	+0.0002/-0.0003 +0.005/-0.008	1.0002 25.405	+0.0002/-0.0003 +0.005/-0.008	1.0006 25.415	+0.0002/-0.0003 +0.005/-0.008	950	3.10 1.41
	CCYR 3 S			N/A								
CYR 3 1/4	CYR 3 1/4 S	.13 3.2	2.13 54.0	.13 3.2	.9994 25.385	+0.0002/-0.0003 +0.005/-0.008	1.0002 25.405	+0.0002/-0.0003 +0.005/-0.008	1.0006 25.415	+0.0002/-0.0003 +0.005/-0.008	880	3.62 1.64
	CCYR 3 1/4 S			N/A								
CYR 3 1/2	CYR 3 1/2 S	.13 3.2	2.44 61.9	.13 3.2	1.1244 28.560	+0.0002/-0.0003 +0.005/-0.008	1.1252 28.580	+0.0002/-0.0003 +0.005/-0.008	1.1256 28.590	+0.0002/-0.0003 +0.005/-0.008	820	4.95 2.25
	CCYR 3 1/2 S			N/A								
CYR 4	CYR 4 S	.13 3.2	2.80 71.0	.13 3.2	1.2494 31.735	+0.0002/-0.0003 +0.005/-0.008	1.2502 31.755	+0.0002/-0.0003 +0.005/-0.008	1.2506 31.765	+0.0002/-0.0003 +0.005/-0.008	700	7.05 3.19
	CCYR 4 S			N/A								

# MCGILL® Inch Cam Follower Bearings



**Basic Construction Type:** Yoke Type Crowned/  
Cylindrical Outside Diameter

**Rolling Elements:** Full Complement/Needle  
Roller

**Bearing Material:** Bearing Quality Steel

**Seal Type:** LUBRI-DISC®

**Lubrication:** Lithium Soap Grease NLGI #2

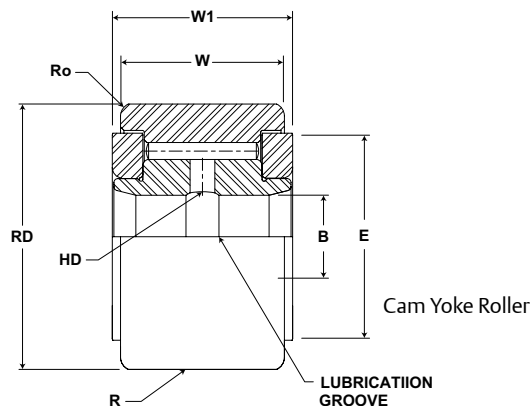

## CYR

Part No.		RD		W		B		W1		R	Track Roller Dynamic Rating	Track Roller Static Rating
W/O Seals	With LUBRI-DISC Seals	Roller Diameter		Roller Width		Bore Diameter		Overall Width		Crown		
		inch mm		inch mm		inch mm		inch mm		Prefix CCYR-XX		
		Nom.	Tol.	Nom.	Tol.	Nom.	Tol.	Nom.	Tol.	inch mm Radius	lb/N	lb/N
-	CYR 5 S	5.000	+0/-0.001	2.750	+0/-0.005	1.750	+0.001/-0.0005	2.875	+0.005/-0.01	Cylindrical	46,575 207,166	135,900 604,483
	CCYR 5 S	127.00	+0/-0.03	69.85	+0/-0.13	44.45	+0.0003/-0.0013	73.03	+0.13/-0.25	48 1,219		
-	CYR 6 S	6.000	+0/-0.001	3.250	+0/-0.005	2.250	+0.001/-0.0005	3.375	+0.005/-0.01	Cylindrical	60,000 266,880	160,900 715,683
	CCYR 6 S	152.40	+0/-0.03	82.55	+0/-0.13	57.15	+0.0003/-0.0013	85.725	+0.13/-0.25	56 1,422		
-	CYR 7 S	7.000	+0/-0.001	3.750	+0/-0.005	2.750	+0.001/-0.0005	3.875	+0.005/-0.01	Cylindrical	75,380 335,290	213,860 951,249
	CCYR 7 S	177.80	+0/-0.03	95.25	+0/-0.13	69.85	+0.0003/-0.0013	98.43	+0.13/-0.25	60 1,524		
-	CYR 8 S	8.000	*	4.250	*	3.255	+0.001/-0 +0.025/-0	4.50	+0.005/-0.01	Cylindrical	92,200 410,106	288,200 1,281,914
	CCYR 8 S	203.20		107.95		82.68		114.3	+0.13/-0.25	40 1,016		
-	CYR 9 S	9.000	*	4.750	*	3.755	+0.001/-0 +0.025/-0	5.00	+0.005/-0.01	Cylindrical	113,260 503,780	366,850 1,631,749
	CCYR 9 S	228.60		120.65		95.38		127.0	+0.13/-0.25	40 1,016		
-	CYR 10 S	10.000	*	5.250	*	4.255	+0.001/-0 +0.025/-0	5.50	+0.005/-0.01	Cylindrical	131,545 585,112	431,130 1,917,666
	CCYR 10 S	254.00		133.35		108.08		139.7	+0.13/-0.25	40 1,016		

Metric dimensions for reference only.

Not all parts are available from stock. Please contact customer service for availability (800) 626-2120.

For more information on bearing capabilities outside of our standard offering, please contact Application Engineering (800) 626-2093.

# Inch Cam Follower Bearings **McGILL**

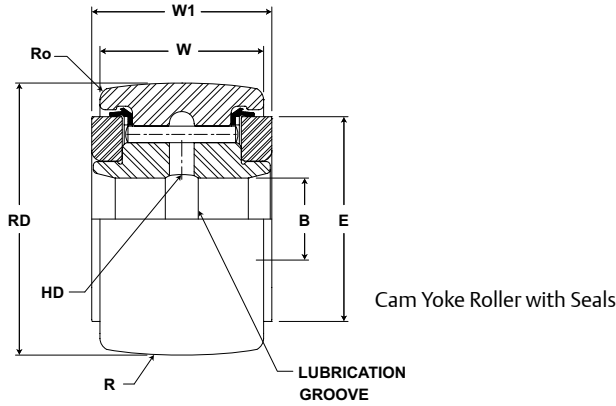

CYR

Part No.		HD	E	Ro	Recommended Shaft Diameters						Limiting Speed	WT
W/O Seals	With LUBRI-DISC Seals	Hole Diameter	Min. Clamping Diameter	Outer Corner	Push Fit		Drive Fit		Press Fit		RPM	Bearing Weight
		inch mm			inch mm		inch mm		inch mm			lb kg
		(Ref)	(Ref)	(Ref)	Nom	Tol	Nom	Tol	Nom	Tol		
-	CYR 5 S	.19 4.8	3.56 90.5	.13 3.2	1.7494 44.435	+0.002/-0.003 +0.005/-0.008	1.7502 44.455	+0.002/-0.003 +0.005/-0.008	1.7506 44.465	+0.002/-0.003 +0.005/-0.008	575	14.34 6.59
	CCYR 5 S			N/A								
-	CYR 6 S	.19 4.8	4.47 113.5	.13 3.2	2.2494 57.135	+0.002/-0.003 +0.005/-0.008	2.2502 57.155	+0.002/-0.003 +0.005/-0.008	2.2506 57.165	+0.002/-0.003 +0.005/-0.008	475	20.16 9.14
	CCYR 6 S			N/A								
-	CYR 7 S	.19 4.8	5.19 131.8	.13 3.2	2.7494 69.835	+0.002/-0.003 +0.005/-0.008	2.7502 69.855	+0.002/-0.003 +0.005/-0.008	2.7506 69.865	+0.002/-0.003 +0.005/-0.008	400	32.43 14.71
	CCYR 7 S			N/A								
-	CYR 8 S	.25 6.4	4.38 111.1	.22 5.6	3.2545 82.664	±0.005 ±0.013	3.2560 82.702	±0.005 ±0.013	3.2565 82.715	±0.005 ±0.013	350	47.30 21.45
	CCYR 8 S			N/A								
-	CYR 9 S	.31 7.9	5.06 128.6	.25 6.4	3.7545 95.364	±0.005 ±0.013	3.7560 95.402	±0.005 ±0.013	3.7565 95.415	±0.005 ±0.013	300	65.70 29.80
	CCYR 9 S			N/A								
-	CYR 10 S	.38 9.5	5.47 138.9	.28 7.1	4.2545 108.064	±0.005 ±0.013	4.2560 108.102	±0.005 ±0.013	4.2565 108.115	±0.005 ±0.013	275	89.20 40.46
	CCYR 10 S			N/A								

# MCGILL® Inch Cam Follower Bearings



- Basic Construction Type:** Stud Type Crowned / Cylindrical Outside Diameter
- Rolling Elements:** Non-Metallic Bushing
- Bearing Material:** Bearing Quality Steel
- Seal Type:** LUBRI-DISC®
- Lubrication:** None - Self Lubricating Bushing
- System Configuration:** Concentric / Eccentric
- Mounting Feature:** Slot / Hex Hole

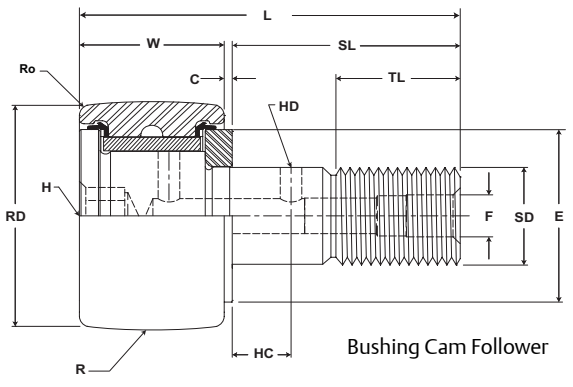

## BCF, BCFE

Part No.	RD		W		SD		SL	C	TL	L	R	ECC	G	BD	Track Roller Dynamic Rating	Track Roller Static Rating
	Roller Diameter		Roller Width		Stud Diameter		Stud Length	Endplate Extension	Minimum Thread Length	Length Overall	Crown	Eccentric				
											Prefix BCCF-XX	Base Modifier BCFE-XX				
	inch mm		inch mm		inch mm		inch mm	inch mm	inch mm	inch mm	inch mm	inch mm				
Nom. Tol.		Nom. Tol.		Nom. Tol.		(Ref)	(Ref)	(Ref)	(Ref)	Radius	(Ref)	+0/- .001 (+0/- .03)	± .001 (± .03)	N/lb	N/lb	
BCF 1/2 S	.500 12.70	+0/- .001 +0/- .03	.375 9.53	+0 / - .005 +0 / - .13	.190 4.83	+ .001/-0 + .03/-0	.625 15.9	.03 .8	.25 6.4	1.03 26.2	Cylindrical	N/A	N/A	N/A	See Load-Speed Chart	
BCF 1/2 SB																
BCCF 1/2 S											7 178					
BCCF 1/2 SB																
BCFE 1/2 S	.500 12.70	+0/- .001 +0/- .03	.375 9.53	+0 / - .005 +0 / - .13	.190 4.83	+ .001/-0 + .03/-0	.625 15.9	.03 .8	.25 6.4	1.03 26.2	Cylindrical	.010 .25	.38 9.5	.25 6.4	See Load-Speed Chart	
BCFE 1/2 SB																
BCCFE 1/2 S											7 178					
BCCFE 1/2 SB																
BCF 9/16 S	.5625 14.29	+0/- .001 +0/- .03	.375 9.53	+0 / - .005 +0 / - .13	.190 4.83	+ .001/-0 + .03/-0	.625 15.9	.03 .8	.25 6.4	1.03 26.2	Cylindrical	N/A	N/A	N/A	See Load-Speed Chart	
BCF 9/16 SB																
BCCF 9/16 S											7 178					
BCCF 9/16 SB																
BCFE 9/16 S	.5625 14.29	+0/- .001 +0/- .03	.375 9.53	+0 / - .005 +0 / - .13	.190 4.83	+ .001/-0 + .03/-0	.625 15.9	.03 .8	.25 6.4	1.03 26.2	Cylindrical	.010 .25	.38 9.5	.25 6.4	See Load-Speed Chart	
BCFE 9/16 SB																
BCCFE 9/16 S											7 178					
BCCFE 9/16 SB																
BCF 5/8 S	.625 15.88	+0/- .001 +0/- .03	.4375 11.11	+0 / - .005 +0 / - .13	.250 6.35	+ .001/-0 + .03/-0	.75 19.1	.03 .8	.31 7.9	1.22 31.0	Cylindrical	N/A	N/A	N/A	See Load-Speed Chart	
BCF 5/8 SB																
BCCF 5/8 S											8 203					
BCCF 5/8 SB																
BCFE 5/8 S	.625 15.88	+0/- .001 +0/- .03	.4375 11.11	+0 / - .005 +0 / - .13	.250 6.35	+ .001/-0 + .03/-0	.75 19.1	.03 .8	.31 7.9	1.22 31.0	Cylindrical	.015 .38	.44 11.1	.38 9.5	See Load-Speed Chart	
BCFE 5/8 SB																
BCCFE 5/8 S											8 203					
BCCFE 5/8 SB																
BCF 11/16 S	.6875 17.46	+0/- .001 +0/- .03	.4375 11.11	+0 / - .005 +0 / - .13	.250 6.35	+ .001/-0 + .03/-0	.75 19.1	.03 .8	.31 7.9	1.22 31.0	Cylindrical	N/A	N/A	N/A	See Load-Speed Chart	
BCF 11/16 SB																
BCCF 11/16 S											8 203					
BCCF 11/16 SB																
BCFE 11/16 S	.6875 17.46	+0/- .001 +0/- .03	.4375 11.11	+0 / - .005 +0 / - .13	.250 6.35	+ .001/-0 + .03/-0	.75 19.1	.03 .8	.31 7.9	1.22 31.0	Cylindrical	.015 .38	.44 11.1	.38 9.5	See Load-Speed Chart	
BCFE 11/16 SB																
BCCFE 11/16 S											8 203					
BCCFE 11/16 SB																

Metric dimensions for reference only.  
 Not all parts are available from stock. Please contact customer service for availability (800) 626-2120.  
 For more information on bearing capabilities outside of our standard offering, please contact Application Engineering (800) 626-2093.

# Inch Cam Follower Bearings **McGILL**

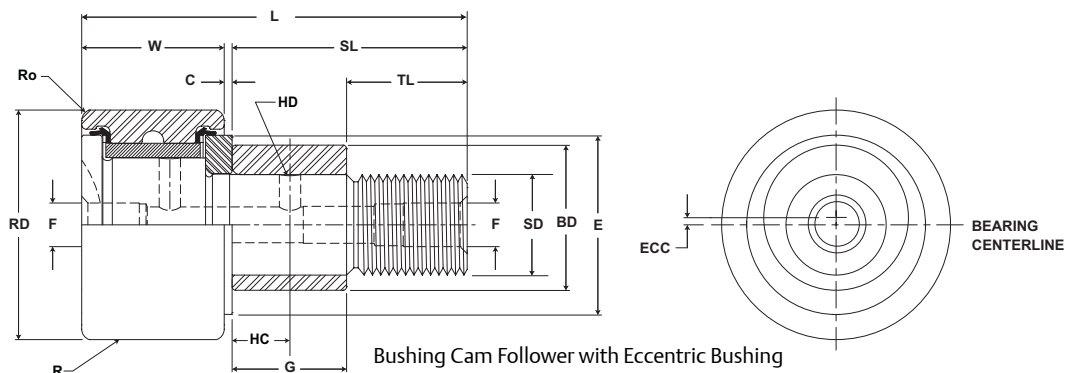

## BCF, BCFE

Part No.	HC	HD	F	H	E	R <sub>0</sub>	Housing Bore Diameter		Thread Type	Clamping Torque	Limiting Speed	WT
	Hole Center	Radial Hole Diameter	Axial Hole Dia or Fitting	Hex Hole	Min Boss Diameter	Outer Corner Radius	inch mm			in-lb Nm	RPM	Bearing Weight
	(Ref)	(Ref)	(Ref)	(Ref)	(Ref)	(Ref)	Norm.	Tol.		lb kg		
BCF 1/2 S						.02						
BCF 1/2 SB			.125	.125	.41	.4	.1903	+0.002/-0.003	10-32	15	See Load-Speed Chart	.04
BCCF 1/2 S	-	-	3.17	3.17	10.4		4.834	+0.005/-0.008		2		.02
BCCF 1/2 SB						N/A						
BCFE 1/2 S						.02						
BCFE 1/2 SB			.125	.125	.41	.4	.253	+0.001/-0.001	10-32	15	See Load-Speed Chart	.04
BCCFE 1/2 S	-	-	3.17	3.17	10.4		6.426	+0.025/-0.025		2		.02
BCCFE 1/2 SB						N/A						
BCF 9/16 S						.02						
BCF 9/16 SB			.125	.125	.41	.4	.1903	+0.002/-0.003	10-32	15	See Load-Speed Chart	.04
BCCF 9/16 S	-	-	3.17	3.17	10.4		4.834	+0.005/-0.008		2		.02
BCCF 9/16 SB						N/A						
BCFE 9/16 S						.02						
BCFE 9/16 SB			.125	.125	.41	.4	.253	+0.001/-0.001	10-32	15	See Load-Speed Chart	.04
BCCFE 9/16 S	-	-	3.17	3.17	10.4		6.426	+0.025/-0.025		2		.02
BCCFE 9/16 SB						N/A						
BCF 5/8 S						.02						
BCF 5/8 SB			.125	.125	.46	.4	.2503	+0.002/-0.003	1/4-28	35	See Load-Speed Chart	.05
BCCF 5/8 S	-	-	3.17	3.17	11.7		6.358	+0.005/-0.008		4		.02
BCCF 5/8 SB						N/A						
BCFE 5/8 S						.02						
BCFE 5/8 SB			.125	.125	.46	.4	.378	+0.001/-0.001	1/4-28	35	See Load-Speed Chart	.05
BCCFE 5/8 S	-	-	3.17	3.17	11.7		9.60	+0.025/-0.025		4		.02
BCCFE 5/8 SB						N/A						
BCF 11/16 S						.02						
BCF 11/16 SB			.125	.125	.46	.4	.2503	+0.002/-0.003	1/4-28	35	See Load-Speed Chart	.06
BCCF 11/16 S	-	-	3.17	3.17	11.7		6.358	+0.005/-0.008		4		.03
BCCF 11/16 SB						N/A						
BCFE 11/16 S						.02						
BCFE 11/16 SB			.125	.125	.46	.4	.378	+0.001/-0.001	1/4-28	35	See Load-Speed Chart	.06
BCCFE 11/16 S	-	-	3.17	3.17	11.7		9.60	+0.025/-0.025		4		.03
BCCFE 11/16 SB						N/A						

# MCGILL® Inch Cam Follower Bearings



- Basic Construction Type:** Stud Type Crowned / Cylindrical Outside Diameter
- Rolling Elements:** Non-Metallic Bushing
- Bearing Material:** Bearing Quality Steel
- Seal Type:** LUBRI-DISC®
- Lubrication:** None - Self Lubricating Bushing
- System Configuration:** Concentric / Eccentric
- Mounting Feature:** Slot / Hex Hole

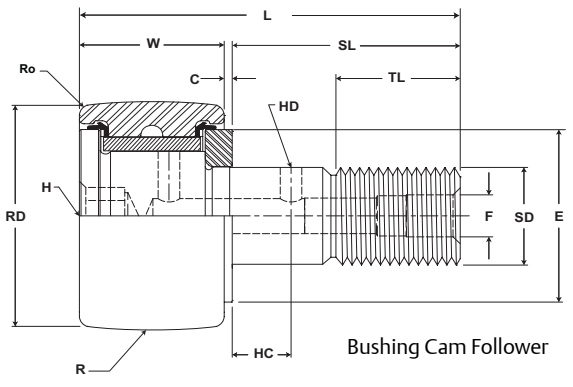

## BCF, BCFE

Part No.	RD		W		SD		SL	C	TL	L	R	ECC	G	BD	Track Roller Dynamic Rating	Track Roller Static Rating
	Roller Diameter		Roller Width		Stud Diameter		Stud Length	Endplate Extension	Minimum Thread Length	Length Overall	Crown	Eccentric				
											Prefix BCCF-XX	Base Modifier BCCE-XX				
	inch mm		inch mm		inch mm		inch mm	inch mm	inch mm	inch mm	inch mm	inch mm				
Nom. Tol.		Nom. Tol.		Nom. Tol.		(Ref)	(Ref)	(Ref)	(Ref)	Radius	(Ref)	+0/- .001 (+0/- .03)	± .001 (± .03)	N/lb	N/lb	
BCF 3/4 S	.750 19.05	+0/- .001 +0/- .03	.500 12.70	+0 / - .005 +0 / - .13	.375 9.53	+ .001/-0 + .03/-0	.875 22.2	.03 .8	.38 9.5	1.41 35.7	Cylindrical	N/A	N/A	N/A	See Load-Speed Chart	
BCF 3/4 SB																
BCCF 3/4 S											10					
BCCF 3/4 SB											254					
BCFE 3/4 S	.750 19.05	+0/- .001 +0/- .03	.500 12.70	+0 / - .005 +0 / - .13	.375 9.53	+ .001/-0 + .03/-0	.875 22.2	.03 .8	.38 9.5	1.41 35.7	Cylindrical	.015 .38	.50 12.7	.50 12.7	See Load-Speed Chart	
BCFE 3/4 SB																
BCCFE 3/4 S											10					
BCCFE 3/4 SB											254					
BCF 7/8 S	.875 22.23	+0/- .001 +0/- .03	.500 12.70	+0 / - .005 +0 / - .13	.375 9.53	+ .001/-0 + .03/-0	.875 22.2	.03 .8	.38 9.5	1.41 35.7	Cylindrical	N/A	N/A	N/A	See Load-Speed Chart	
BCF 7/8 SB																
BCCF 7/8 S											10					
BCCF 7/8 SB											254					
BCFE 7/8 S	.875 22.23	+0/- .001 +0/- .03	.500 12.70	+0 / - .005 +0 / - .13	.375 9.53	+ .001/-0 + .03/-0	.875 22.2	.03 .8	.38 9.5	1.41 35.7	Cylindrical	.015 .38	.50 12.7	.50 12.7	See Load-Speed Chart	
BCFE 7/8 SB																
BCCFE 7/8 S											10					
BCCFE 7/8 SB											254					
BCF 1 S	1.000 25.40	+0/- .001 +0/- .03	.625 15.88	+0 / - .005 +0 / - .13	.4375 11.11	+ .001/-0 + .03/-0	1.00 25.4	.03 .8	.50 12.7	1.66 42.1	Cylindrical	N/A	N/A	N/A	See Load-Speed Chart	
BCF 1 SB																
BCCF 1 S											12					
BCCF 1 SB											305					
BCFE 1 S	1.000 25.40	+0/- .001 +0/- .03	.625 15.88	+0 / - .005 +0 / - .13	.4375 11.11	+ .001/-0 + .03/-0	1.00 25.4	.03 .8	.50 12.7	1.66 42.1	Cylindrical	.030 .76	.50 12.7	.63 15.9	See Load-Speed Chart	
BCFE 1 SB																
BCCFE 1 S											12					
BCCFE 1 SB											305					
BCF 1 1/8 S	1.125 28.58	+0/- .001 +0/- .03	.625 15.88	+0 / - .005 +0 / - .13	.4375 11.11	+ .001/-0 + .03/-0	1.00 25.4	.03 .8	.50 12.7	1.66 42.1	Cylindrical	N/A	N/A	N/A	See Load-Speed Chart	
BCF 1 1/8 SB																
BCCF 1 1/8 S											12					
BCCF 1 1/8 SB											305					
BCFE 1 1/8 S	1.125 28.58	+0/- .001 +0/- .03	.625 15.88	+0 / - .005 +0 / - .13	.4375 11.11	+ .001/-0 + .03/-0	1.00 25.4	.03 .8	.50 12.7	1.66 42.1	Cylindrical	.030 .76	.50 12.7	.63 15.9	See Load-Speed Chart	
BCFE 1 1/8 SB																
BCCFE 1 1/8 S											12					
BCCFE 1 1/8 SB											305					

Metric dimensions for reference only.  
 Not all parts are available from stock. Please contact customer service for availability (800) 626-2120.  
 For more information on bearing capabilities outside of our standard offering, please contact Application Engineering (800) 626-2093.

# Inch Cam Follower Bearings **McGILL**

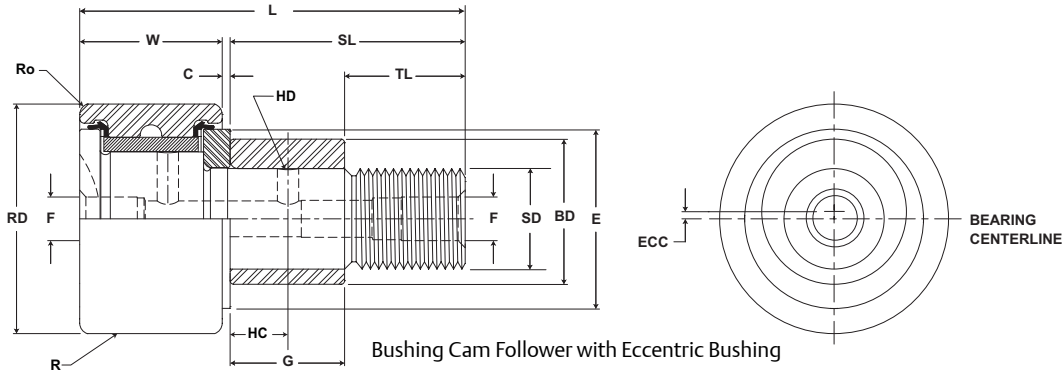

## BCF, BCFE

Part No.	HC	HD	F	H	E	Ro	Housing Bore Diameter		Thread Type	Clamping Torque	Limiting Speed	WT
	Hole Center	Radial Hole Diameter	Axial Hole Dia or Fitting	Hex Hole	Min Boss Diameter	Outer Corner Radius	in mm			in-lb Nm	RPM	Bearing Weight
	(Ref)	(Ref)	(Ref)	(Ref)	(Ref)	(Ref)	Norm.	Tol.		lb kg		
BCF 3/4 S						.02						
BCF 3/4 SB	.25	.09	.1875	.1875	.61	.4	.3753	+0.002/-0.003	3/8-24	95	See Load-Speed Chart	.07
BCCF 3/4 S	6.4	2.4	4.76	4.76	15.5	N/A	9.533	+0.005/-0.008				
BCCF 3/4 SB												
BCFE 3/4 S						.02						
BCFE 3/4 SB	.25	.09	.1875	.1875	.61	.4	.503	+0.001/-0.001	3/8-24	95	See Load-Speed Chart	.07
BCCFE 3/4 S	6.4	2.4	4.76	4.76	15.5	N/A	12.77	+0.025/-0.025				
BCCFE 3/4 SB												
BCF 7/8 S						.02						
BCF 7/8 SB	.25	.09	.1875	.1875	.61	.4	.3753	+0.002/-0.003	3/8-24	95	See Load-Speed Chart	.09
BCCF 7/8 S	6.4	2.4	4.76	4.76	15.5	N/A	9.533	+0.005/-0.008				
BCCF 7/8 SB												
BCFE 7/8 S						.02						
BCFE 7/8 SB	.25	.09	.1875	.1875	.61	.4	.503	+0.001/-0.001	3/8-24	95	See Load-Speed Chart	.09
BCCFE 7/8 S	6.4	2.4	4.76	4.76	15.5	N/A	12.77	+0.025/-0.025				
BCCFE 7/8 SB												
BCF 1 S						.03						
BCF 1 SB	.25	.09	.1875	.25	.78	.8	.4378	+0.002/-0.003	7/16-20	250	See Load-Speed Chart	.17
BCCF 1 S	6.4	2.4	4.76	6.4	19.8	N/A	11.120	+0.005/-0.008				
BCCF 1 SB												
BCFE 1 S						.03						
BCFE 1 SB	.25	.09	.1875	.25	.78	.8	.628	+0.001/-0.001	7/16-20	250	See Load-Speed Chart	.17
BCCFE 1 S	6.4	2.4	4.76	6.4	19.8	N/A	15.95	+0.025/-0.025				
BCCFE 1 SB												
BCF 1 1/8 S						.03						
BCF 1 1/8 SB	.25	.09	.1875	.25	.78	.8	.4378	+0.002/-0.003	7/16-20	250	See Load-Speed Chart	.19
BCCF 1 1/8 S	6.4	2.4	4.76	6.4	19.8	N/A	11.120	+0.005/-0.008				
BCCF 1 1/8 SB												
BCFE 1 1/8 S						.03						
BCFE 1 1/8 SB	.25	.09	.1875	.25	.78	.8	.628	+0.001/-0.001	7/16-20	250	See Load-Speed Chart	.19
BCCFE 1 1/8 S	6.4	2.4	4.76	6.4	19.8	N/A	15.95	+0.025/-0.025				
BCCFE 1 1/8 SB												

Metric dimensions for reference only.

Clamping torque is based on dry threads. If threads are lubricated, use half of value shown.



# MCGILL® Inch Cam Follower Bearings



- Basic Construction Type:** Stud Type Crowned / Cylindrical Outside Diameter
- Rolling Elements:** Non-Metallic Bushing
- Bearing Material:** Bearing Quality Steel
- Seal Type:** LUBRI-DISC®
- Lubrication:** None - Self Lubricating Bushing
- System Configuration:** Concentric / Eccentric
- Mounting Feature:** Slot / Hex Hole

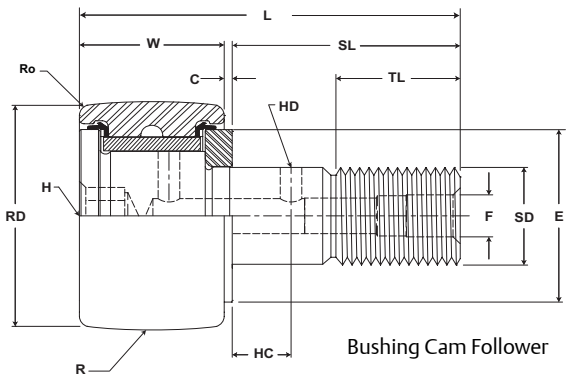

## BCF, BCFE

Part No.	RD		W		SD		SL	C	TL	L	R	ECC	G	BD	Track Roller Dynamic Rating	Track Roller Static Rating
	Roller Diameter		Roller Width		Stud Diameter		Stud Length	Endplate Extension	Minimum Thread Length	Length Overall	Crown Prefix BCCF-XX	Eccentric Base Modifier BCFE-XX				
	inch mm		inch mm		inch mm		inch mm	inch mm	inch mm	inch mm	inch mm	inch mm				
	Nom.	Tol.	Nom.	Tol.	Nom.	Tol.	(Ref)	(Ref)	(Ref)	(Ref)	Radius	(Ref)	+0/- .001 (+/- .03)	± .001 (± .03)		
BCF 1 1/4 S	1.250 31.75	+0/- .001 +0/- .03	.750 19.05	+0 / - .005 +0 / - .13	.500 12.70	+.001/-0 +.03/-0	1.25 31.8	.03 .8	.63 15.9	2.03 51.6	Cylindrical	N/A	N/A	N/A	See Load-Speed Chart	
BCF 1 1/4 SB																
BCCF 1 1/4 S																
BCCF 1 1/4 SB																
BCFE 1 1/4 S	1.250 31.75	+0/- .001 +0/- .03	.750 19.05	+0 / - .005 +0 / - .13	.500 12.70	+.001/-0 +.03/-0	1.25 31.8	.03 .8	.63 15.9	2.03 51.6	Cylindrical	.030 .76	.63 15.9	.69 17.4	See Load-Speed Chart	
BCFE 1 1/4 SB																
BCCFE 1 1/4 S																
BCCFE 1 1/4 SB																
BCF 1 3/8 S	1.375 34.93	+0/- .001 +0/- .03	.750 19.05	+0 / - .005 +0 / - .13	.500 12.70	+.001/-0 +.03/-0	1.25 31.8	.03 .8	.63 15.9	2.03 51.6	Cylindrical	N/A	N/A	N/A	See Load-Speed Chart	
BCF 1 3/8 SB																
BCCF 1 3/8 S																
BCCF 1 3/8 SB																
BCFE 1 3/8 S	1.375 34.93	+0/- .001 +0/- .03	.750 19.05	+0 / - .005 +0 / - .13	.500 12.70	+.001/-0 +.03/-0	1.25 31.8	.03 .8	.63 15.9	2.03 51.6	Cylindrical	.030 .76	.63 15.9	.69 17.4	See Load-Speed Chart	
BCFE 1 3/8 SB																
BCCFE 1 3/8 S																
BCCFE 1 3/8 SB																
BCF 1 1/2 S	1.500 38.10	+0/- .001 +0/- .03	.875 22.23	+0 / - .005 +0 / - .13	.625 15.88	+.001/-0 +.03/-0	1.50 38.1	.03 .8	.75 19.1	2.41 61.1	Cylindrical	N/A	N/A	N/A	See Load-Speed Chart	
BCF 1 1/2 SB																
BCCF 1 1/2 S																
BCCF 1 1/2 SB																
BCFE 1 1/2 S	1.500 38.10	+0/- .001 +0/- .03	.875 22.23	+0 / - .005 +0 / - .13	.625 15.88	+.001/-0 +.03/-0	1.50 38.1	.03 .8	.75 19.1	2.41 61.1	Cylindrical	.030 .76	.75 19.1	.88 22.2	See Load-Speed Chart	
BCFE 1 1/2 SB																
BCCFE 1 1/2 S																
BCCFE 1 1/2 SB																
BCF 1 5/8 S	1.625 41.28	+0/- .001 +0/- .03	.875 22.23	+0 / - .005 +0 / - .13	.625 15.88	+.001/-0 +.03/-0	1.50 38.1	.03 .8	.75 19.1	2.41 61.1	Cylindrical	N/A	N/A	N/A	See Load-Speed Chart	
BCF 1 5/8 SB																
BCCF 1 5/8 S																
BCCF 1 5/8 SB																
BCFE 1 5/8 S	1.625 41.28	+0/- .001 +0/- .03	.875 22.23	+0 / - .005 +0 / - .13	.625 15.88	+.001/-0 +.03/-0	1.50 38.1	.03 .8	.75 19.1	2.41 61.1	Cylindrical	.030 .76	.75 19.1	.88 22.2	See Load-Speed Chart	
BCFE 1 5/8 SB																
BCCFE 1 5/8 S																
BCCFE 1 5/8 SB																

Metric dimensions for reference only.  
 Not all parts are available from stock. Please contact customer service for availability (800) 626-2120.  
 For more information on bearing capabilities outside of our standard offering, please contact Application Engineering (800) 626-2093.

# Inch Cam Follower Bearings **McGILL**

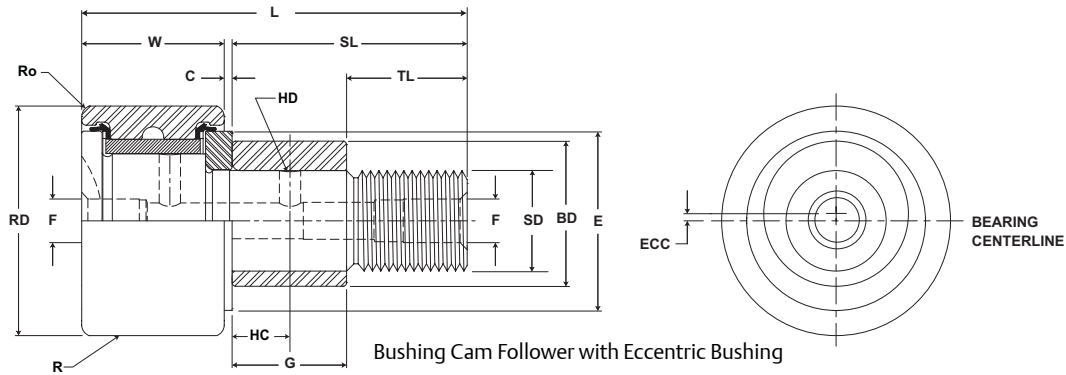

## BCF, BCFE

Part No.	HC	HD	F	H	E	Ro	Housing Bore Diameter		Thread Type	Clamping Torque	Limiting Speed	WT
	Hole Center	Radial Hole Diameter	Axial Hole Dia or Fitting	Hex Hole	Min Boss Diameter	Outer Corner Radius	inch mm			in-lb Nm	RPM	Bearing Weight
	(Ref)	(Ref)	(Ref)	(Ref)	(Ref)	(Ref)	Nom.	Tol.		lb kg		
BCF 1 1/4 S	.31 7.9	.09 2.4	.1875 4.76	.25 6.4	.98 25.0	.03 .8	.5003 12.708	+.0002/- .0003 +.0005/- .0008	1/2-20	350 40	See Load-Speed Chart	.30 .14
BCF 1 1/4 SB						N/A						
BCCF 1 1/4 S						N/A						
BCCF 1 1/4 SB						N/A						
BCFE 1 1/4 S	.31 7.9	.09 2.4	.1875 4.76	.25 6.4	.98 25.0	.03 .8	.690 17.52	+.001/- .001 +.025/- .025	1/2-20	350 40	See Load-Speed Chart	.30 .14
BCFE 1 1/4 SB						N/A						
BCCFE 1 1/4 S						N/A						
BCCFE 1 1/4 SB						N/A						
BCF 1 3/8 S	.31 7.9	.09 2.4	.1875 4.76	.25 6.4	.98 25.0	.05 1.2	.5003 12.708	+.0002/- .0003 +.0005/- .0008	1/2-20	350 40	See Load-Speed Chart	.35 .16
BCF 1 3/8 SB						N/A						
BCCF 1 3/8 S						N/A						
BCCF 1 3/8 SB						N/A						
BCFE 1 3/8 S	.31 7.9	.09 2.4	.1875 4.76	.25 6.4	.98 25.0	.05 1.2	.690 17.52	+.001/- .001 +.025/- .025	1/2-20	350 40	See Load-Speed Chart	.35 .16
BCFE 1 3/8 SB						N/A						
BCCFE 1 3/8 S						N/A						
BCCFE 1 3/8 SB						N/A						
BCF 1 1/2 S	.38 9.5	.09 2.4	.1875 4.76	.31 7.9	1.09 27.8	.06 1.6	.6253 15.883	+.0002/- .0003 +.0005/- .0008	5/8-18	650 73	See Load-Speed Chart	.53 .24
BCF 1 1/2 SB						N/A						
BCCF 1 1/2 S						N/A						
BCCF 1 1/2 SB						N/A						
BCFE 1 1/2 S	.38 9.5	.09 2.4	.1875 4.76	.31 7.9	1.09 27.8	.06 1.6	.878 22.30	+.001/- .001 +.025/- .025	5/8-18	650 73	See Load-Speed Chart	.53 .24
BCFE 1 1/2 SB						N/A						
BCCFE 1 1/2 S						N/A						
BCCFE 1 1/2 SB						N/A						
BCF 1 5/8 S	.38 9.5	.09 2.4	.1875 4.76	.31 7.9	1.09 27.8	.06 1.6	.6253 15.883	+.0002/- .0003 +.0005/- .0008	5/8-18	650 73	See Load-Speed Chart	.60 .27
BCF 1 5/8 SB						N/A						
BCCF 1 5/8 S						N/A						
BCCF 1 5/8 SB						N/A						
BCFE 1 5/8 S	.38 9.5	.09 2.4	.1875 4.76	.31 7.9	1.09 27.8	.06 1.6	.878 22.30	+.001/- .001 +.025/- .025	5/8-18	650 73	See Load-Speed Chart	.60 .27
BCFE 1 5/8 SB						N/A						
BCCFE 1 5/8 S						N/A						
BCCFE 1 5/8 SB						N/A						

# MCGILL® Inch Cam Follower Bearings



- Basic Construction Type:** Stud Type Crowned / Cylindrical Outside Diameter
- Rolling Elements:** Non-Metallic Bushing
- Bearing Material:** Bearing Quality Steel
- Seal Type:** LUBRI-DISC®
- Lubrication:** None - Self Lubricating Bushing
- System Configuration:** Concentric / Eccentric
- Mounting Feature:** Slot / Hex Hole

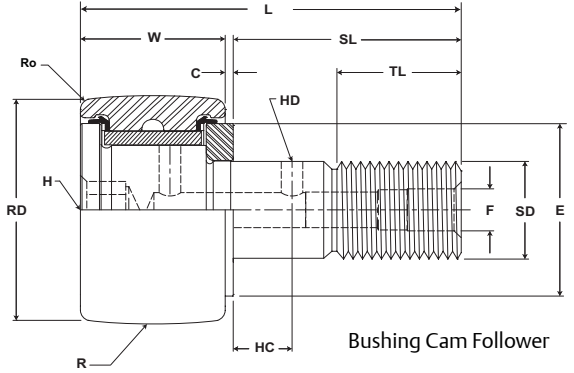

## BCF, BCFE

Part No.	RD		W		SD		SL	C	TL	L	R	ECC	G	BD	Track Roller Dynamic Rating	Track Roller Static Rating	
	Roller Diameter		Roller Width		Stud Diameter		Stud Length	Endplate Extension	Minimum Thread Length	Length Overall	Crown	Eccentric					
											Prefix BCCF-XX	Base Modifier BCFE-XX					
	inch mm		inch mm		inch mm		inch mm	inch mm	inch mm	inch mm	inch mm	inch mm					
Nom.		Tol.		Nom.		Tol.		(Ref)	(Ref)	(Ref)	(Ref)	Radius	(Ref)	+0/-.001 (+0/-.03)	±.001 (±.03)	N/lb	N/lb
BCF 1 3/4 S	1.750 44.45	+0/-.001 +0/-.03	1.000 25.40	0 / - .005 +0 / - .13	.750 19.05	+.001/-0 +.03/-0	1.75 44.5	.03 .8	.88 22.2	2.78 70.6	Cylindrical	N/A	N/A	N/A	See Load-Speed Chart		
BCF 1 3/4 SB																	
BCCF 1 3/4 S																	
BCCF 1 3/4 SB																	
BCFE 1 3/4 S	1.750 44.45	+0/-.001 +0/-.03	1.000 25.40	0 / - .005 +0 / - .13	.750 19.05	+.001/-0 +.03/-0	1.75 44.5	.03 .8	.88 22.2	2.78 70.6	Cylindrical	.030 .76	.88 22.2	.00 25.4	See Load-Speed Chart		
BCFE 1 3/4 SB																	
BCCFE 1 3/4 S																	
BCCFE 1 3/4 SB																	
BCF 1 7/8 S	1.875 47.63	+0/-.001 +0/-.03	1.000 25.40	0 / - .005 +0 / - .13	.750 19.05	+.001/-0 +.03/-0	1.75 44.5	.03 .8	.88 22.2	2.78 70.6	Cylindrical	N/A	N/A	N/A	See Load-Speed Chart		
BCF 1 7/8 SB																	
BCCF 1 7/8 S																	
BCCF 1 7/8 SB																	
BCFE 1 7/8 S	1.875 47.63	+0/-.001 +0/-.03	1.000 25.40	0 / - .005 +0 / - .13	.750 19.05	+.001/-0 +.03/-0	1.75 44.5	.03 .8	.88 22.2	2.78 70.6	Cylindrical	.030 .76	.88 22.2	.00 25.4	See Load-Speed Chart		
BCFE 1 7/8 SB																	
BCCFE 1 7/8 S																	
BCCFE 1 7/8 SB																	
BCF 2 S	2.000 50.80	+0/-.001 +0/-.03	1.250 31.75	0 / - .005 +0 / - .13	.875 22.23	+.001/-0 +.03/-0	2.00 50.8	.03 .8	2.00 50.8	3.28 83.3	Cylindrical	N/A	N/A	N/A	See Load-Speed Chart		
BCF 2 SB																	
BCCF 2 S																	
BCCF 2 SB																	
BCFE 2 S	2.000 50.80	+0/-.001 +0/-.03	1.250 31.75	0 / - .005 +0 / - .13	.875 22.23	+.001/-0 +.03/-0	2.00 50.8	.03 .8	2.00 50.8	3.28 83.3	Cylindrical	.030 .76	.00 25.4	.19 30.1	See Load-Speed Chart		
BCFE 2 SB																	
BCCFE 2 S																	
BCCFE 2 SB																	
BCF 2 1/4 S	2.250 57.15	+0/-.001 +0/-.03	1.250 31.75	0 / - .005 +0 / - .13	.875 22.23	+.001/-0 +.03/-0	2.00 50.8	.03 .8	2.00 50.8	3.28 83.3	Cylindrical	N/A	N/A	N/A	See Load-Speed Chart		
BCF 2 1/4 SB																	
BCCF 2 1/4 S																	
BCCF 2 1/4 SB																	
BCFE 2 1/4 S	2.250 57.15	+0/-.001 +0/-.03	1.250 31.75	0 / - .005 +0 / - .13	.875 22.23	+.001/-0 +.03/-0	2.00 50.8	.03 .8	2.00 50.8	3.28 83.3	Cylindrical	.030 .76	.00 25.4	.19 30.1	See Load-Speed Chart		
BCFE 2 1/4 SB																	
BCCFE 2 1/4 S																	
BCCFE 2 1/4 SB																	

Metric dimensions for reference only.

Not all parts are available from stock. Please contact customer service for availability (800) 626-2120.

For more information on bearing capabilities outside of our standard offering, please contact Application Engineering (800) 626-2093.

# Inch Cam Follower Bearings **McGILL**

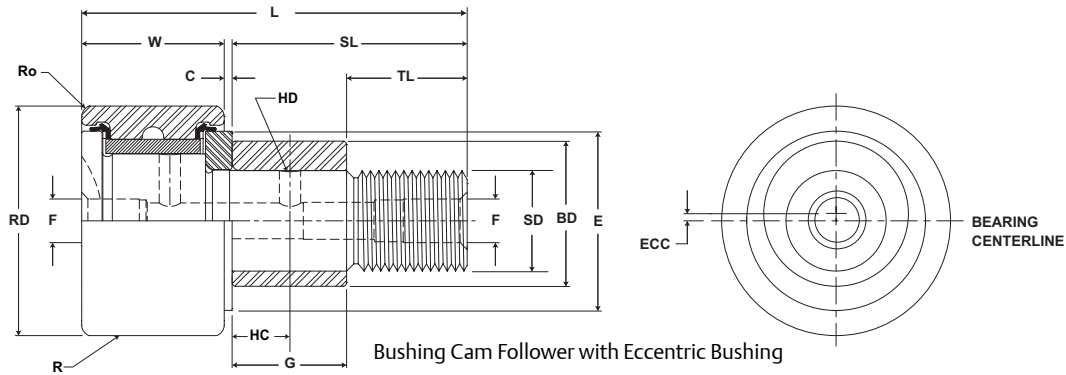

## BCF, BCFE

Part No.	HC	HD	F	H	E	Ro	Housing Bore Diameter		Thread Type	Clamping Torque	Limiting Speed	WT
	Hole Center	Radial Hole Diameter	Axial Hole Dia or Fitting	Hex Hole	Min Boss Diameter	Outer Corner Radius	inch mm			in-lb Nm	RPM	Bearing Weight
	(Ref)	(Ref)	(Ref)	(Ref)	(Ref)	(Ref)	Norm.	Tol.		lb kg		
BCF 1 3/4 S	.44 11.1	.125 3	.1875 4.76	.31 7.9	1.25 31.8	.06 1.6	.7503 19.058	+.0002/- .0003 +.0005/- .0008	3/4-16	1,250 141	See Load-Speed Chart	.84 .38
BCF 1 3/4 SB						N/A						
BCCF 1 3/4 S						N/A						
BCCF 1 3/4 SB						N/A						
BCFE 1 3/4 S	.44 11.1	.125 3	.1875 4.76	.31 7.9	1.25 31.8	.06 1.6	1.003 25.47	+.001/- .001 +.025/- .025	3/4-16	1,250 141	See Load-Speed Chart	.84 .38
BCFE 1 3/4 SB						N/A						
BCCFE 1 3/4 S						N/A						
BCCFE 1 3/4 SB						N/A						
BCF 1 7/8 S	.44 11.1	.125 3	.1875 4.76	.31 7.9	1.25 31.8	.06 1.6	.7503 19.058	+.0002/- .0003 +.0005/- .0008	3/4-16	1,250 141	See Load-Speed Chart	.95 .43
BCF 1 7/8 SB						N/A						
BCCF 1 7/8 S						N/A						
BCCF 1 7/8 SB						N/A						
BCFE 1 7/8 S	.44 11.1	.125 3	.1875 4.76	.31 7.9	1.25 31.8	.06 1.6	1.003 25.47	+.001/- .001 +.025/- .025	3/4-16	1,250 141	See Load-Speed Chart	.95 .43
BCFE 1 7/8 SB						N/A						
BCCFE 1 7/8 S						N/A						
BCCFE 1 7/8 SB						N/A						
BCF 2 S	.50 12.7	.125 3	.1875 4.76	.44 11.1	1.41 35.7	.09 2.4	.8753 22.233	+.0002/- .0003 +.0005/- .0008	7/8-14	1,500 170	See Load-Speed Chart	1.36 .62
BCF 2 SB						N/A						
BCCF 2 S						N/A						
BCCF 2 SB						N/A						
BCFE 2 S	.50 12.7	.125 3	.1875 4.76	.44 11.1	1.41 35.7	.09 2.4	1.190 30.22	+.001/- .001 +.025/- .025	7/8-14	1,500 170	See Load-Speed Chart	1.36 .62
BCFE 2 SB						N/A						
BCCFE 2 S						N/A						
BCCFE 2 SB						N/A						
BCF 2 1/4 S	.50 12.7	.125 3	.1875 4.76	.44 11.1	1.41 35.7	.09 2.4	.8753 22.233	+.0002/- .0003 +.0005/- .0008	7/8-14	1,500 170	See Load-Speed Chart	1.65 .75
BCF 2 1/4 SB						N/A						
BCCF 2 1/4 S						N/A						
BCCF 2 1/4 SB						N/A						
BCFE 2 1/4 S	.50 12.7	.125 3	.1875 4.76	.44 11.1	1.41 35.7	.09 2.4	.8753 22.233	+.001/- .001 +.025/- .025	7/8-14	1,500 170	See Load-Speed Chart	1.65 .75
BCFE 2 1/4 SB						N/A						
BCCFE 2 1/4 S						N/A						
BCCFE 2 1/4 SB						N/A						

# MCGILL® Inch Cam Follower Bearings



- Basic Construction Type:** Stud Type Crowned / Cylindrical Outside Diameter
- Rolling Elements:** Non-Metallic Bushing
- Bearing Material:** Bearing Quality Steel
- Seal Type:** LUBRI-DISC®
- Lubrication:** None - Self Lubricating Bushing
- System Configuration:** Concentric / Eccentric
- Mounting Feature:** Slot / Hex Hole

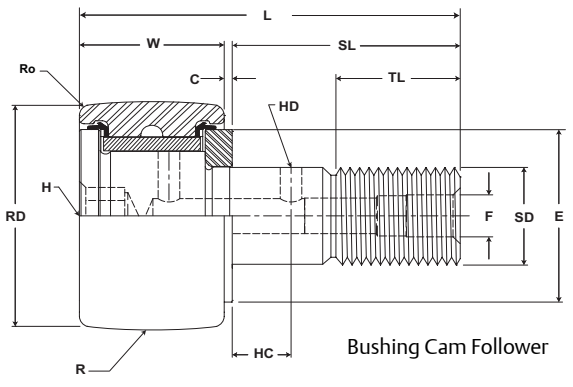

## BCF, BCFE

Part No.	RD		W		SD		SL	C	TL	L	R	ECC	G	BD	Track Roller Dynamic Rating	Track Roller Static Rating
	Roller Diameter		Roller Width		Stud Diameter		Stud Length	Endplate Extension	Minimum Thread Length	Length Overall	Crown Prefix BCCF-XX	Eccentric Base Modifier BCFE-XX				
	inch mm		inch mm		inch mm		inch mm	inch mm	inch mm	inch mm	inch mm	inch mm				
	Nom.	Tol.	Nom.	Tol.	Nom.	Tol.	(Ref)	(Ref)	(Ref)	(Ref)	Radius	(Ref)	+0/- .001 (+0/- .03)	± .001 (± .03)		
BCF 2 1/2 S	2.500 63.50	+0/- .001 +0/- .03	1.500 38.10	+0 / - .005 +0 / - .13	1.000 25.40	+ .001/-0 + .03/-0	2.25 57.2	.03 .8	2.25 57.2	3.78 96.0	Cylindrical	N/A	N/A	N/A	See Load-Speed Chart	
BKF 2 1/2 SB																
BCCF 2 1/2 S																
BCCF 2 1/2 SB																
BCFE 2 1/2 S	2.500 63.50	+0/- .001 +0/- .03	1.500 38.10	+0 / - .005 +0 / - .13	1.000 25.40	+ .001/-0 + .03/-0	2.25 57.2	.03 .8	2.25 57.2	3.78 96.0	Cylindrical	.030 .76	.13 28.6	.38 34.9	See Load-Speed Chart	
BKF 2 1/2 SB																
BCCF 2 1/2 S																
BCCF 2 1/2 SB																
BCF 2 3/4 S	2.750 69.85	+0/- .001 +0/- .03	1.500 38.10	+0 / - .005 +0 / - .13	1.000 25.40	+ .001/-0 + .03/-0	2.25 57.2	.03 .8	2.25 57.2	3.78 96.0	Cylindrical	N/A	N/A	N/A	See Load-Speed Chart	
BKF 2 3/4 SB																
BCCF 2 3/4 S																
BCCF 2 3/4 SB																
BCFE 2 3/4 S	2.750 69.85	+0/- .001 +0/- .03	1.500 38.10	+0 / - .005 +0 / - .13	1.000 25.40	+ .001/-0 + .03/-0	2.25 57.2	.03 .8	2.25 57.2	3.78 96.0	Cylindrical	.030 .76	.13 28.6	.38 34.9	See Load-Speed Chart	
BKF 2 3/4 SB																
BCCF 2 3/4 S																
BCCF 2 3/4 SB																
BCF 3 S	3.000 76.20	+0/- .001 +0/- .03	1.750 44.45	+0 / - .005 +0 / - .13	1.250 31.75	+ .001/-0 + .03/-0	2.50 63.5	.03 .8	2.50 63.5	4.28 108.7	Cylindrical	N/A	N/A	N/A	See Load-Speed Chart	
BKF 3 SB																
BCCF 3 S																
BCCF 3 SB																
BCFE 3 S	3.000 76.20	+0/- .001 +0/- .03	1.750 44.45	+0 / - .005 +0 / - .13	1.250 31.75	+ .001/-0 + .03/-0	2.50 63.5	.03 .8	2.50 63.5	4.28 108.7	Cylindrical	.060 .52	.25 31.8	.75 44.5	See Load-Speed Chart	
BKF 3 SB																
BCCF 3 S																
BCCF 3 SB																
BCF 3 1/4 S	3.250 82.55	+0/- .001 +0/- .03	1.750 44.45	+0 / - .005 +0 / - .13	1.250 31.75	+ .001/-0 + .03/-0	2.50 63.5	.03 .8	2.50 63.5	4.28 108.7	Cylindrical	N/A	N/A	N/A	See Load-Speed Chart	
BKF 3 1/4 SB																
BCCF 3 1/4 S																
BCCF 3 1/4 SB																
BCFE 3 1/4 S	3.250 82.55	+0/- .001 +0/- .03	1.750 44.45	+0 / - .005 +0 / - .13	1.250 31.75	+ .001/-0 + .03/-0	2.50 63.5	.03 .8	2.50 63.5	4.28 108.7	Cylindrical	.060 .52	.25 31.8	.75 44.5	See Load-Speed Chart	
BKF 3 1/4 SB																
BCCF 3 1/4 S																
BCCF 3 1/4 SB																

Metric dimensions for reference only.  
 Not all parts are available from stock. Please contact customer service for availability (800) 626-2120.  
 For more information on bearing capabilities outside of our standard offering, please contact Application Engineering (800) 626-2093.

# Inch Cam Follower Bearings **McGILL**

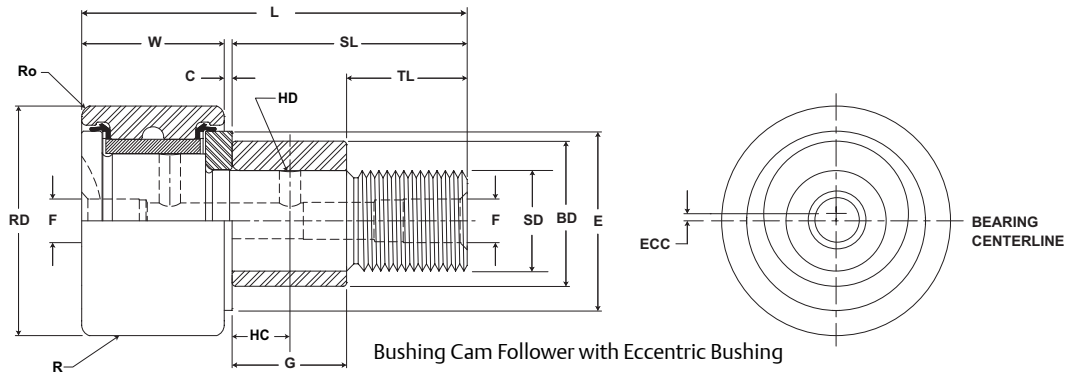

## BCF, BCFE

Part No.	HC	HD	F	H	E	Ro	Housing Bore Diameter		Thread Type	Clamping Torque	Limiting Speed	WT
	Hole Center	Radial Hole Diameter	Axial Hole Dia or Fitting	Hex Hole	Min Boss Diameter	Outer Corner Radius	inch mm			in-lb Nm	RPM	Bearing Weight
	(Ref)	(Ref)	(Ref)	(Ref)	(Ref)	(Ref)	Norm.	Tol.		lb kg		
BCF 2 1/2 S						.09						
BCF 2 1/2 SB	.56	.125	.1875	.50	1.69	2.4	1.0003	+0.0002/-0.0003	1-14	2,250	See Load-Speed Chart	2.50
BCCF 2 1/2 S	14.3	3	4.76	12.7	42.9	N/A	25.408	+0.0005/-0.0008				
BCCF 2 1/2 SB												
BCFE 2 1/2 S						.09						
BCFE 2 1/2 SB	.56	.125	.1875	.50	1.69	2.4	1.378	+0.001/-0.001	1-14	2,250	See Load-Speed Chart	2.50
BCCFE 2 1/2 S	14.3	3	4.76	12.7	42.9	N/A	35.00	+0.025/-0.025				
BCCFE 2 1/2 SB												
BCF 2 3/4 S						.09						
BCF 2 3/4 SB	.56	.125	.1875	.50	1.69	2.4	1.0003	+0.0002/-0.0003	1-14	2,250	See Load-Speed Chart	2.93
BCCF 2 3/4 S	14.3	3	4.76	12.7	42.9	N/A	25.408	+0.0005/-0.0008				
BCCF 2 3/4 SB												
BCFE 2 3/4 S						.09						
BCFE 2 3/4 SB	.56	.125	.1875	.50	1.69	2.4	1.378	+0.001/-0.001	1-14	2,250	See Load-Speed Chart	2.93
BCCFE 2 3/4 S	14.3	3	4.76	12.7	42.9	N/A	35.00	+0.025/-0.025				
BCCFE 2 3/4 SB												
BCF 3 S						.13						
BCF 3 SB	.63	.125	.25	.75	2.13	3.2	1.2503	+0.0002/-0.0003	1 1/4-12	3,450	See Load-Speed Chart	4.20
BCCF 3 S	15.9	3	6.4	19.1	54.0	N/A	31.758	+0.0005/-0.0008				
BCCF 3 SB												
BCFE 3 S						.13						
BCFE 3 SB	.63	.125	.25	.75	2.13	3.2	1.753	+0.001/-0.001	1 1/4-12	3,450	See Load-Speed Chart	4.20
BCCFE 3 S	15.9	3	6.4	19.1	54.0	N/A	44.52	+0.025/-0.025				
BCCFE 3 SB												
BCF 3 1/4 S						.13						
BCF 3 1/4 SB	.63	.125	.25	.75	2.13	3.2	1.2503	+0.0002/-0.0003	1 1/4-12	3,450	See Load-Speed Chart	4.81
BCCF 3 1/4 S	15.9	3	6.4	19.1	54.0	N/A	31.758	+0.0005/-0.0008				
BCCF 3 1/4 SB												
BCFE 3 1/4 S						.13						
BCFE 3 1/4 SB	.63	.125	.25	.75	2.13	3.2	1.753	+0.001/-0.001	1 1/4-12	3,450	See Load-Speed Chart	4.81
BCCFE 3 1/4 S	15.9	3	6.4	19.1	54.0	N/A	44.52	+0.025/-0.025				
BCCFE 3 1/4 SB												

# MCGILL® Inch Cam Follower Bearings



- Basic Construction Type:** Stud Type Crowned / Cylindrical Outside Diameter
- Rolling Elements:** Non-Metallic Bushing
- Bearing Material:** Bearing Quality Steel
- Seal Type:** LUBRI-DISC®
- Lubrication:** None - Self Lubricating Bushing
- System Configuration:** Concentric / Eccentric
- Mounting Feature:** Slot / Hex Hole

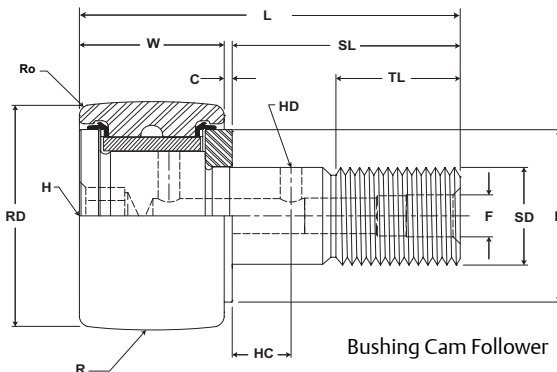

## BCF, BCFE

Part No.	RD		W		SD		SL	C	TL	L	R	ECC	G	BD	Track Roller Dynamic Rating	Track Roller Static Rating
With LUBRI-DISC Seals	Roller Diameter		Roller Width		Stud Diameter		Stud Length	Endplate Extension	Minimum Thread Length	Length Overall	Crown Prefix BCCF-XX	Eccentric Base Modifier BCCE-XX			N/lb	N/lb
	inch mm		inch mm		inch mm		inch mm	inch mm	inch mm		inch mm	inch mm				
	Nom.	Tol.	Nom.	Tol.	Nom.	Tol.	(Ref)	(Ref)	(Ref)	(Ref)	Radius	(Ref)	+0/- .001 (+0/- .03)	± .001 (± .03)		
BCF 3 1/2 S BCF 3 1/2 SB BCCF 3 1/2 S BCCF 3 1/2 SB	3.500 88.90	+0/- .001 +0/- .03	2.000 50.80	+0 / - .005 +0 / - .13	1.375 34.93	+ .001/-0 + .03/-0	2.75 69.9	.03 .8	2.75 69.9	4.78 121.4	Cylindrical 30 762	N/A	N/A	N/A	See Load-Speed Chart	
BCFE 3 1/2 S BCFE 3 1/2 SB BCCFE 3 1/2 S BCCFE 3 1/2 SB	3.500 88.90	+0/- .001 +0/- .03	2.000 50.80	+0 / - .005 +0 / - .13	1.375 34.93	+ .001/-0 + .03/-0	2.75 69.9	.03 .8	2.75 69.9	4.78 121.4	Cylindrical 30 762	.060 .52	.38 34.9	.81 46.0	See Load-Speed Chart	
BCF 4 S BCF 4 SB BCCF 4 S BCCF 4 SB	4.000 101.60	+0/- .001 +0/- .03	2.250 57.15	+0 / - .005 +0 / - .13	1.500 38.10	+ .001/-0 + .03/-0	3.50 88.9	.03 .8	3.50 88.9	5.78 146.8	Cylindrical 30 762	N/A	N/A	N/A	See Load-Speed Chart	
BCFE 4 S BCFE 4 SB BCCFE 4 S BCCFE 4 SB	4.000 101.60	+0/- .001 +0/- .03	2.250 57.15	+0 / - .005 +0 / - .13	1.500 38.10	+ .001/-0 + .03/-0	3.50 88.9	.03 .8	3.50 88.9	5.78 146.8	Cylindrical 30 762	.060 .52	.00 50.8	.00 50.8	See Load-Speed Chart	

Metric dimensions for reference only.

Not all parts are available from stock. Please contact customer service for availability (800) 626-2120.

For more information on bearing capabilities outside of our standard offering, please contact Application Engineering (800) 626-2093.

# Inch Cam Follower Bearings **McGILL**

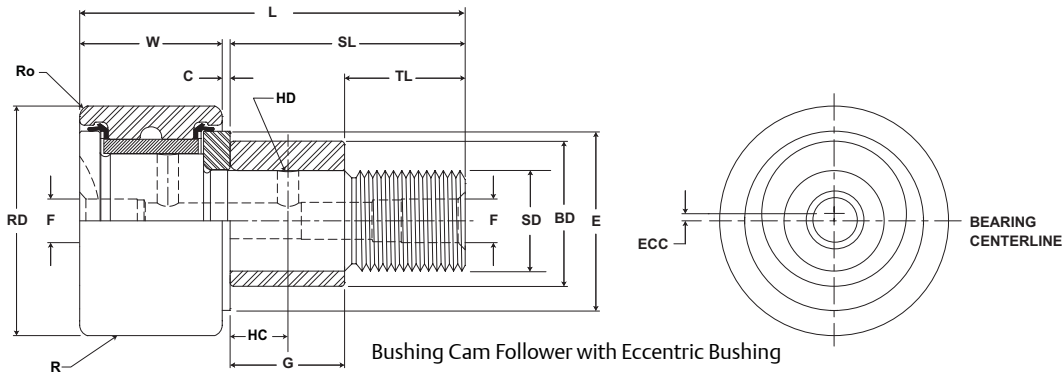

## BCF, BCFE

Part No.	HC	HD	F	H	E	Ro	Housing Bore Diameter		Thread Type	Clamping Torque	Limiting Speed	WT
	Hole Center	Radial Hole Diameter	Axial Hole Dia or Fitting	Hex Hole	Min Boss Diameter	Outer Corner Radius	inch mm			in-lb Nm	RPM	Bearing Weight
	(Ref)	(Ref)	(Ref)	(Ref)	(Ref)	(Ref)	Nom.	Tol.		lb kg		
BCF 3 1/2 S	.69 17.5	.125 3	.25 6.4	.75 19.1	2.44 61.9	.13	1.3753 34.933	+.0002/- .0003 +.0005/- .0008	1 3/8-12	4,200 475	See Load-Speed Chart	6.42 2.91
BCF 3 1/2 SB						3.2						
BCCF 3 1/2 S						N/A						
BCCF 3 1/2 SB						N/A						
BCFE 3 1/2 S	.69 17.5	.125 3	.25 6.4	.75 19.1	2.44 61.9	.13	1.815 46.10	+.001/- .001 +.025/- .025	1 3/8-12	4,200 475	See Load-Speed Chart	6.42 2.91
BCFE 3 1/2 SB						3.2						
BCCFE 3 1/2 S						N/A						
BCCFE 3 1/2 SB						N/A						
BCF 4 S	.75 19.1	.125 3	.25 6.4	.75 19.1	2.80 71.0	.13	1.5003 38.108	+.0002/- .0003 +.0005/- .0008	1 1/2-12	5,000 565	See Load-Speed Chart	9.46 4.29
BCF 4 SB						3.2						
BCCF 4 S						N/A						
BCCF 4 SB						N/A						
BCFE 4 S	.75 19.1	.125 3	.25 6.4	.75 19.1	2.80 71.0	.13	2.003 50.85	+.001/- .001 +.025/- .025	1 1/2-12	5,000 565	See Load-Speed Chart	9.46 4.29
BCFE 4 SB						3.2						
BCCFE 4 S						N/A						
BCCFE 4 SB						N/A						



# McGILL® Inch Cam Follower Bearings



- Basic Construction Type:** Yoke Type Crowned / Cylindrical Outside Diameter
- Rolling Elements:** Non-Metallic Bushing
- Bearing Material:** Bearing Quality Steel
- Seal Type:** LUBRI-DISC®
- Lubrication:** None - Self Lubricating Bushing
- System Configuration:** Concentric / Eccentric / Heavy Stud
- Mounting Feature:** Slot / Hex Hole

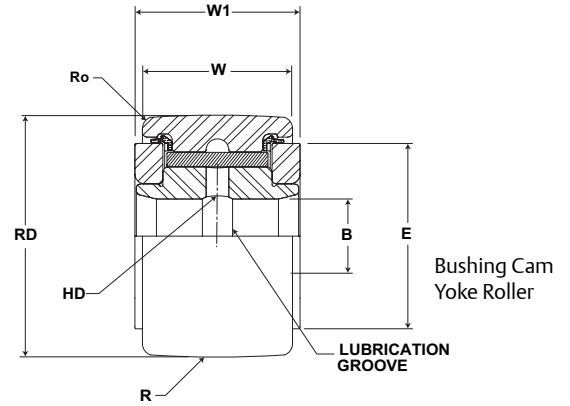

## BCYR

Part No.	RD		W		B		W1	R	Track Roller Dynamic Rating lb/N	Track Roller Static Rating lb/N
	Roller Diameter		Roller Width		Bore Diameter		Endplate Extension	Crown		
	Prefix BCCYR-XX		inch mm		inch mm		inch mm	Radius		
	Nom.	Tol.	Nom.	Tol.	Nom	Tol	(Ref)			
BCYR 3/4 S	.750	+0/-.001	.500	+0/-.001	.250	+0.002/-0.004	.56	Cylindrical	See Load-Speed Chart	
BCCYR 3/4 S	19.05	+0/-.03	12.70	+0/-.03	6.35	+0.005/-0.010	14.3	10 254		
BCYR 7/8 S	.875	+0/-.001	.500	+0/-.001	.250	+0.002/-0.004	.56	Cylindrical	See Load-Speed Chart	
BCCYR 7/8 S	22.23	+0/-.03	12.70	+0/-.03	6.35	+0.005/-0.010	14.3	10 254		
BCYR 1 S	1.000	+0/-.001	.625	+0/-.001	.313	+0.002/-0.004	.69	Cylindrical	See Load-Speed Chart	
BCCYR 1 S	25.40	+0/-.03	15.88	+0/-.03	7.94	+0.005/-0.010	17.5	12 305		
BCYR 1 1/8 S	1.125	+0/-.001	.625	+0/-.001	.313	+0.002/-0.004	.69	Cylindrical	See Load-Speed Chart	
BCCYR 1 1/8 S	28.58	+0/-.03	15.88	+0/-.03	7.94	+0.005/-0.010	17.5	12 305		
BCYR 1 1/4 S	1.250	+0/-.001	.750	+0/-.001	.375	+0.002/-0.004	.81	Cylindrical	See Load-Speed Chart	
BCCYR 1 1/4 S	31.75	+0/-.03	19.05	+0/-.03	9.53	+0.005/-0.010	20.6	14 356		
BCYR 1 3/8 S	1.375	+0/-.001	.750	+0/-.001	.375	+0.002/-0.004	.81	Cylindrical	See Load-Speed Chart	
BCCYR 1 3/8 S	34.93	+0/-.03	19.05	+0/-.03	9.53	+0.005/-0.010	20.6	14 356		
BCYR 1 1/2 S	1.500	+0/-.001	.875	+0/-.001	.438	+0.002/-0.004	.94	Cylindrical	See Load-Speed Chart	
BCCYR 1 1/2 S	38.10	+0/-.03	22.23	+0/-.03	11.11	+0.005/-0.010	23.8	20 508		
BCYR 1 5/8 S	1.625	+0/-.001	.875	+0/-.001	.438	+0.002/-0.004	.94	Cylindrical	See Load-Speed Chart	
BCCYR 1 5/8 S	41.28	+0/-.03	22.23	+0/-.03	11.11	+0.005/-0.010	23.8	20 508		
BCYR 1 3/4 S	1.750	+0/-.001	1.000	+0/-.001	.500	+0.002/-0.004	1.06	Cylindrical	See Load-Speed Chart	
BCCYR 1 3/4 S	44.45	+0/-.03	25.40	+0/-.03	12.70	+0.005/-0.010	27.0	20 508		

Metric dimensions for reference only.

Not all parts are available from stock. Please contact customer service for availability (800) 626-2120.

For more information on bearing capabilities outside of our standard offering, please contact Application Engineering (800) 626-2093.

# Inch Cam Follower Bearings **MCGILL**



## BCYR

Part No.	HC	E	Ro	PF	PFT	PF	PFT	PF	PFT	Limiting Speed	WT
	Hole Center	Min Boss Diameter	Outer Corner	Recommended Shaft Diameters							RPM
	(Ref)	(Ref)	(Ref)	Push Fit		Drive Fit		Press Fit		RPM	lb kg
				inch mm	inch mm	inch mm	inch mm	inch mm	inch mm		
With LUBRI-DISC Seals	(Ref)	(Ref)	(Ref)	Nom	Tol	Nom	Tol	Nom	Tol		
BCYR 3/4 S	.25 6.4	.61 15.5	.02 .4	.2495 6.337	±.0002 ±.005	.2495 6.337	±.0002 ±.005	.2495 6.337	±.0002 ±.005	See Load-Speed Chart	.06 .03
BCCYR 3/4 S			N/A								
BCYR 7/8 S	.25 6.4	.61 15.5	.02 .4	.2495 6.337	±.0002 ±.005	.2495 6.337	±.0002 ±.005	.2495 6.337	±.0002 ±.005	See Load-Speed Chart	.08 .04
BCCYR 7/8 S			N/A								
BCYR 1 S	.25 6.4	.78 19.8	.03 .8	.3120 7.925	±.0002 ±.005	.3120 7.925	±.0002 ±.005	.3120 7.925	±.0002 ±.005	See Load-Speed Chart	.15 .07
BCCYR 1 S			N/A								
BCYR 1 1/8 S	.25 6.4	.78 19.8	.03 .8	.3120 7.925	±.0002 ±.005	.3120 7.925	±.0002 ±.005	.3120 7.925	±.0002 ±.005	See Load-Speed Chart	.17 .08
BCCYR 1 1/8 S			N/A								
BCYR 1 1/4 S	.31 7.9	.98 25.0	.03 .8	.3745 9.512	±.0002 ±.005	.3745 9.512	±.0002 ±.005	.3745 9.512	±.0002 ±.005	See Load-Speed Chart	.24 .11
BCCYR 1 1/4 S			N/A								
BCYR 1 3/8 S	.31 7.9	.98 25.0	.05 1.2	.3745 9.512	±.0002 ±.005	.3745 9.512	±.0002 ±.005	.3745 9.512	±.0002 ±.005	See Load-Speed Chart	.30 .14
BCCYR 1 3/8 S			N/A								
BCYR 1 1/2 S	.38 9.5	1.09 27.8	.06 1.6	.4370 11.100	±.0002 ±.005	.4370 11.100	±.0002 ±.005	.4370 11.100	±.0002 ±.005	See Load-Speed Chart	.41 .19
BCCYR 1 1/2 S			N/A								
BCYR 1 5/8 S	.38 9.5	1.09 27.8	.06 1.6	.4370 11.100	±.0002 ±.005	.4370 11.100	±.0002 ±.005	.4370 11.100	±.0002 ±.005	See Load-Speed Chart	.50 .23
BCCYR 1 5/8 S			N/A								
BCYR 1 3/4 S	.44 11.1	1.25 31.8	.06 1.6	.4995 12.687	±.0002 ±.005	.4995 12.687	±.0002 ±.005	.4995 12.687	±.0002 ±.005	See Load-Speed Chart	.64 .29
BCCYR 1 3/4 S			N/A								

# MCGILL® Inch Cam Follower Bearings



- Basic Construction Type:** Yoke Type Crowned / Cylindrical Outside Diameter
- Rolling Elements:** Non-Metallic Bushing
- Bearing Material:** Bearing Quality Steel
- Seal Type:** LUBRI-DISC®
- Lubrication:** None - Self Lubricating Bushing
- System Configuration:** Concentric / Eccentric / Heavy Stud
- Mounting Feature:** Slot / Hex Hole

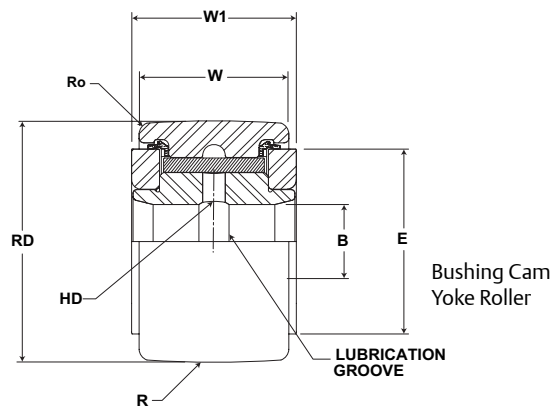

## BCYR

Part No.	RD		W		B		W1	R	Track Roller Dynamic Rating lb/N	Track Roller Static Rating lb/N
	Roller Diameter		Roller Width		Bore Diameter		Endplate Extension	Crown		
	Prefix BCCYR-XX									
	inch	mm	inch	mm	inch	mm	inch	mm		
	Nom.	Tol.	Nom.	Tol.	Nom.	Tol.	(Ref)	Radius		
BCYR 1 7/8 S	1.875	+0/-0.001	1.000	+0/-0.001	.500	+0.0002/-0.0004	1.06	Cylindrical	See Load-Speed Chart	
BCCYR 1 7/8 S	47.63	+0/-0.03	25.40	+0/-0.03	12.70	+0.0005/-0.0010	27.0	20 508		
BCYR 2 S	2.000	+0/-0.001	1.250	+0/-0.001	.625	+0.0002/-0.0004	1.31	Cylindrical	See Load-Speed Chart	
BCCYR 2 S	50.80	+0/-0.03	31.75	+0/-0.03	15.88	+0.0005/-0.0010	33.3	24 610		
BCYR 2 1/4 S	2.250	+0/-0.001	1.250	+0/-0.001	.625	+0.0002/-0.0004	1.31	Cylindrical	See Load-Speed Chart	
BCCYR 2 1/4 S	57.15	+0/-0.03	31.75	+0/-0.03	15.88	+0.0005/-0.0010	33.3	24 610		
BCYR 2 1/2 S	2.500	+0/-0.001	1.500	+0/-0.001	.750	+0.0002/-0.0004	1.56	Cylindrical	See Load-Speed Chart	
BCCYR 2 1/2 S	63.50	+0/-0.03	38.10	+0/-0.03	19.05	+0.0005/-0.0010	39.7	30 762		
BCYR 2 3/4 S	2.750	+0/-0.001	1.500	+0/-0.001	.750	+0.0002/-0.0004	1.56	Cylindrical	See Load-Speed Chart	
BCCYR 2 3/4 S	69.85	+0/-0.03	38.10	+0/-0.03	19.05	+0.0005/-0.0010	39.7	30 762		
BCYR 3 S	3.000	+0/-0.001	1.750	+0/-0.001	1.000	+0.0001/-0.0005	1.81	Cylindrical	See Load-Speed Chart	
BCCYR 3 S	76.20	+0/-0.03	44.45	+0/-0.03	25.40	+0.0003/-0.0013	46.0	30 762		
BCYR 3 1/4 S	3.250	+0/-0.001	1.750	+0/-0.001	1.000	+0.0001/-0.0005	1.81	Cylindrical	See Load-Speed Chart	
BCCYR 3 1/4 S	82.55	+0/-0.03	44.45	+0/-0.03	25.40	+0.0003/-0.0013	46.0	30 762		
BCYR 3 1/2 S	3.500	+0/-0.001	2.000	+0/-0.001	1.125	+0.0001/-0.0005	2.06	Cylindrical	See Load-Speed Chart	
BCCYR 3 1/2 S	88.90	+0/-0.03	50.80	+0/-0.03	28.58	+0.0003/-0.0013	52.4	30 762		
BCYR 4 S	4.000	+0/-0.001	2.250	+0/-0.001	1.250	+0.0001/-0.0005	2.06	Cylindrical	See Load-Speed Chart	
BCCYR 4 S	101.60	+0/-0.03	57.15	+0/-0.03	31.75	+0.0003/-0.0013	52.4	30 762		

Metric dimensions for reference only.

Not all parts are available from stock. Please contact customer service for availability (800) 626-2120.

For more information on bearing capabilities outside of our standard offering, please contact Application Engineering (800) 626-2093.

# Inch Cam Follower Bearings **MCGILL**



## BCYR

Part No.	HC	E	Ro	PF	PFT	PF	PFT	PF	PFT	Limiting Speed	WT
	Hole Center	Min Boss Diameter	Outer Corner	Recommended Shaft Diameters							RPM
	(Ref)	(Ref)	(Ref)	Push Fit		Drive Fit		Press Fit		RPM	lb kg
				inch mm	inch mm	inch mm	inch mm	inch mm	inch mm		
				Nom	Tol	Nom	Tol	Nom	Tol		
BCYR 1 7/8 S	.44	1.25	.06	.4995	±.0002	.4995	±.0002	.4995	±.0002	See Load-Speed Chart	.80
BCCYR 1 7/8 S	11.1	31.8	N/A	12.687	±.005	12.687	±.005	12.687	±.005		.36
BCYR 2 S	.50	1.41	.09	.6245	±.0002	.6245	±.0002	.6245	±.0002	See Load-Speed Chart	1.05
BCCYR 2 S	12.7	35.7	N/A	15.862	±.005	15.862	±.005	15.862	±.005		.48
BCYR 2 1/4 S	.50	1.41	.09	.6245	±.0002	.6245	±.0002	.6245	±.0002	See Load-Speed Chart	1.32
BCCYR 2 1/4 S	12.7	35.7	N/A	15.862	±.005	15.862	±.005	15.862	±.005		.59
BCYR 2 1/2 S	.56	1.69	.09	.7495	±.0002	.7495	±.0002	.7495	±.0002	See Load-Speed Chart	1.80
BCCYR 2 1/2 S	14.3	42.9	N/A	19.037	±.005	19.037	±.005	19.037	±.005		.82
BCYR 2 3/4 S	.56	1.69	.09	.7495	±.0002	.7495	±.0002	.7495	±.0002	See Load-Speed Chart	2.25
BCCYR 2 3/4 S	14.3	42.9	N/A	19.037	±.005	19.037	±.005	19.037	±.005		1.02
BCYR 3 S	.63	2.13	.13	.9994	±.0002	.9994	±.0002	.9994	±.0002	See Load-Speed Chart	3.10
BCCYR 3 S	15.9	54.0	N/A	25.385	±.005	25.385	±.005	25.385	±.005		1.41
BCYR 3 1/4 S	.63	2.13	.13	.9994	±.0002	.9994	±.0002	.9994	±.0002	See Load-Speed Chart	3.62
BCCYR 3 1/4 S	15.9	54.0	N/A	25.385	±.005	25.385	±.005	25.385	±.005		1.64
BCYR 3 1/2 S	.69	2.44	.13	1.1244	±.0002	1.1244	±.0002	1.1244	±.0002	See Load-Speed Chart	4.95
BCCYR 3 1/2 S	17.5	61.9	N/A	28.560	±.005	28.560	±.005	28.560	±.005		2.25
BCYR 4 S	.75	2.80	.13	1.2494	±.0002	1.2494	±.0002	1.2494	±.0002	See Load-Speed Chart	7.05
BCCYR 4 S	19.1	71.0	N/A	31.735	±.005	31.735	±.005	31.735	±.005		3.19

## McGill Metric Cam Followers

McGill Metric CAMROL bearings are available with either a full complement, or caged (retainer type) set of needles featuring black oxide treated bearing steel while conforming to ISO standard envelope dimensions for use mechanical automation or linear motion applications. Our basic features each contribute to improved performance, while the LUBRI-DISC® seal option helps prevent metal to metal contact within the bearing while providing a barrier for contaminant entry and allow venting of excess or old grease during lubrication. In addition to the seal option these bearings are available with several dimensional choices and combinations to provide a solution specific for the application. Within the following section you can learn more about these features and how they can be applied to your application.

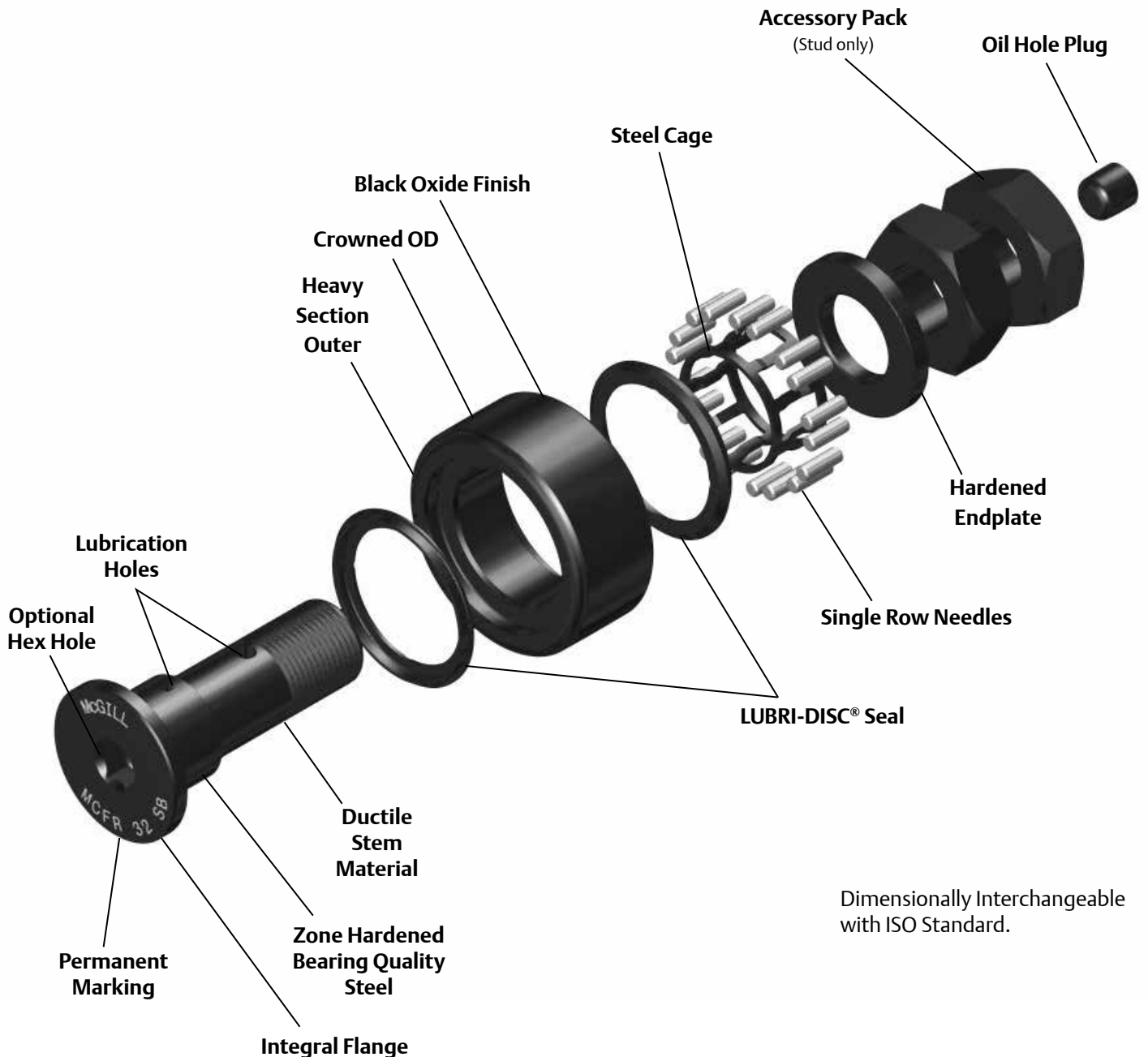

# Cam Follower Metric Nomenclature

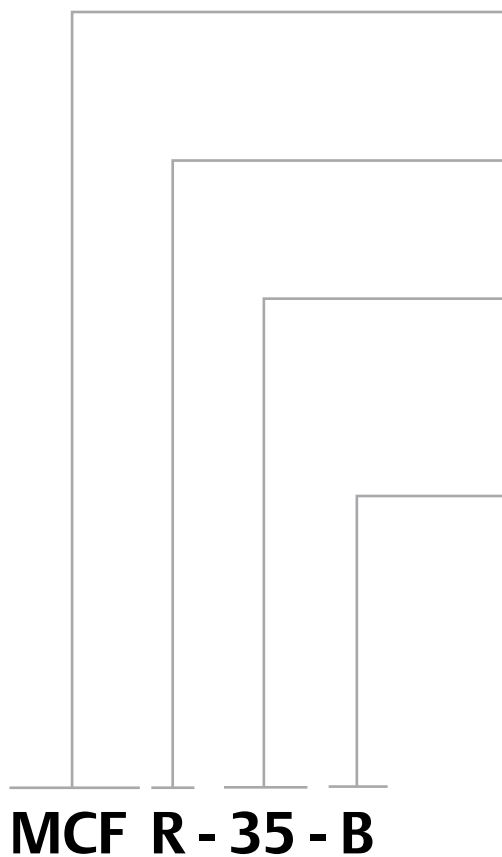

## Basic Type, Construction

- MCF - Metric Cam Follower
- MCYR - Metric Cam Yoke Roller

## Construction Suffix

- R - Retained (Caged) Rolling Elements
- E - Eccentric Bushing

## Size

- Metric Stud Type: O.D. In mm
- Metric Yoke Type: Bore In mm
- A - Asian Dimensional Standard

## Optional Suffix

- S - LUBRI-DISC<sup>®</sup> Seal
- B - Broach (Hex Hole)
- X - Cylindrical O.D.



## Features and Benefits

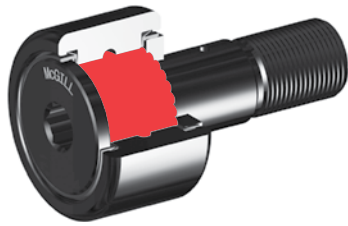

### Single Row Full Complement Needle Rollers

The needle roller diameter, length, and number have been optimized to provide a high dynamic and static load rating, contained within industry standard bearing envelope dimensions.



### Heavy Section Outer

The heavy section outer helps support radial loading and provide proper rolling element support.



### Cylindrical Outside Diameter (OD)

The cylindrical OD can improve performance in certain applications such as improved track capacity by maximizing the contact area with the track.



### Zone Hardened Raceways

Heat treatment used to precisely harden working surfaces of the raceway and flange. The hardened surfaces provide support for the rolling element contact stresses, while keeping the core of the inner ductile to help absorb shock loads.

## Features and Benefits continued

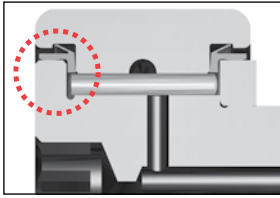

### Integral Flange - Stud Type

The integral flange helps maintain bearing integrity throughout the bearing life. Zone hardened to provide wear resistance from incidental contact with the outer or rollers, and provides a sealing surface with LUBRI-DISC<sup>®</sup> seal option.

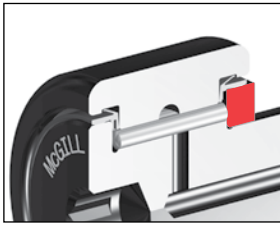

### Hardened Endplate

The endplate provides a locating shoulder when mounting the stud or yoke style cam follower. Also, similar to the flange, the endplate must resist wear from incidental contact with the outer or rollers. The hardened and ground endplate provides a sealing surface with LUBRI-DISC<sup>®</sup> seal option.



### Roll Formed Threads - Stud Type

Roll forming is the process used to produce threads. By moving the material into shape instead of cutting the threads, the threads are produced to meet class 6G tolerances and are work hardened resulting in improved holding power. Available in both Asian (with "A" suffix) or European Metric as standard.

### Factory Grease Fill

The cam follower and cam yoke roller bearings are factory lubricated with a medium temperature grease. Contact Application Engineering when application conditions require special lubricants.

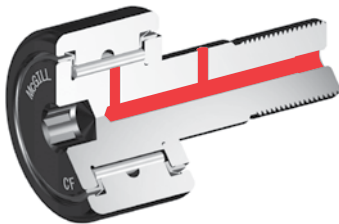

### Lubrication Holes

Most sizes of McGill CAMROL bearings include lubrication hole(s) to accept a standard drive fitting or an included plug. The oil hole plug is recommended for closing unused lubrication hole to help protect against bearing contamination or lubrication loss.

McGill CAMROL Yoke roller bearings include a lubrication hole to provide a passage for lubrication to the rolling elements from the yoke roller bore. The customer supplied shaft must provide an axial lubrication path to supply bearing.



## Features and Benefits continued



### Black Oxide Finish

Bearings have a black oxide finish on all external surfaces.



### Permanent Marking

Part number permanently marked on bearing face, helps bearing identification after years of service.

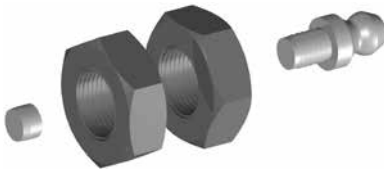

### Installation Accessory Pack

All McGill Metric Cam followers include (2) jam nuts to ensure proper thread type (Asian / European), Fitting and plug to help provide proper lubrication path to the rolling elements and prevent contamination from entering the bearing through a unused hole.

## Options



### Retainer Type

The retainer (cage) option provides heat-treated steel cage for improved durability and wear resistance. The needle separation produces larger lubrication reservoir and helps achieve higher bearing speeds.. The cages are designed with two rollers per pockets (except 13, 16 and 19mm OD's) to help improve static and dynamic load ratings.

## Options



### LUBRI-DISC<sup>®</sup> Seal

The CAMROL standard for seals, the LUBRI-DISC seal not only helps keep contaminants out and lubrication in the bearing, but with an integral back plate to separate the metal to metal contact between the outer ring and endplate(s) or flange. The back plate feature reduce friction resulting in lower operating temperatures which can extend grease life and allowing for higher operating speeds. Our seal also includes vents to help prevent seal blowout during relubrication. The LUBRI-DISC seal option has a good balance of sealing and low drag operation essential to a precision cam follower suited for most industrial applications.

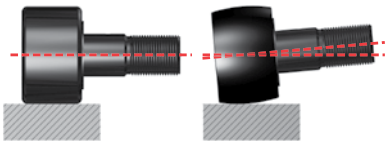

### Crowned Outside Diameter (OD)

A crown on the OD of a cam follower bearing can help increase bearing life versus a standard cylindrical cam follower. The crown achieves this performance by helping to distribute the stress on the outer ring and rolling elements resulting from misalignment due to mounting inaccuracy or stud deflection. The crown may also help reduce outer skidding in turntable or rotary applications. Not all applications may see the benefit of a crowned OD, consult Application Engineering for guidance for your application.



### Hex Hole (Broached)

The hex hole can aide in the installation and removal of stud type cam followers by a more positive hold on the cam follower stud versus a standard screw driver slot. The hex feature is identified with a "B" since it is produced using a broach process. Bearing relubrication from flange end must be considered for sizes under 3".

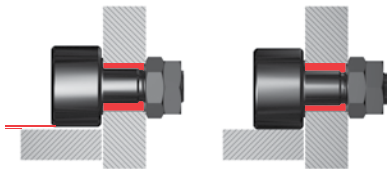

### Eccentric Stud

Eccentric stud option provides a means of adjusting the radial position of the bearing, which can improve the load sharing of inline bearing combinations. Cam follower load sharing helps reduce operation costs by reducing premature failures due to overloaded bearings, the need of precise mounting hole location tolerances and providing ability to realign bearing due to track wear. Eccentric bushing is press fit on stud and unhardened to permit dowel or setscrew for permanent locking.

## Additional Options



**BHT**  
Broached (Hex) hole at threaded end of cam follower stud.



**THT**  
Threaded axial lubrication hole at threaded end of cam follower stud.



**THF**  
Threaded axial lubrication hole at flanged end of cam follower stud. Available with all screw driver slot cam followers or broached cam followers over 3”.



**THB**  
Threaded axial oil hole on both ends of cam follower stud. Available with all screw driver slot cam followers or broached cam followers over 3”.



**ALG**  
Annular lubrication groove at cam follower stem radial lubrication hole.

## **Custom Capabilities**

- *Customer specified factory grease fill*
- *Grease fitting installed*
- *Stud or thread length modifications*
- *Roller diameter variations or tolerances*
- *Cam followers grouped or matched diameter tolerance / run out sets*
- *Custom engineered to order designs*

# McGILL® Metric CAMROL Bearings



- Basic Construction Type:** Stud Type Crowned / Cylindrical Outside Diameter
- Rolling Elements:** Full Complement / Retained (Caged) Needle Roller
- Bearing Material:** Bearing Quality Steel
- Seal Type:** LUBRI-DISC®
- Lubrication:** Lithium Soap Grease NLGI #2
- System Configuration:** Concentric / Eccentric
- Mounting Feature:** Slot / Hex Hole

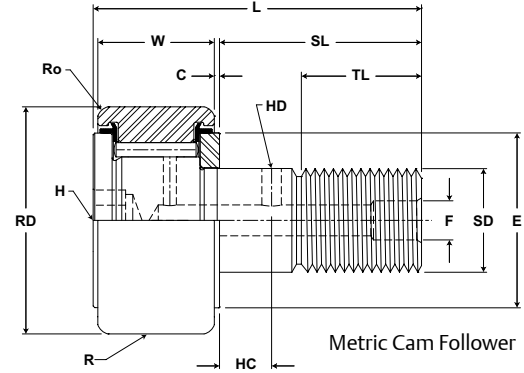

## MCF, MCFE

Part No.		RD		W		SD		SL	C	TL	L	R	ECC	G	BD	Track Roller Dynamic Rating	Track Roller Static Rating			
W/O Seals	With LUBRI-DISC Seals	Roller Diameter		Roller Width		Stud Diameter		Stud Length	Endplate Extension	Minimum Thread Length	Length Overall	Cylindrical	Eccentric							
		mm inch		mm inch		mm inch		mm inch	mm inch	mm inch	mm inch	mm inch	Base Modifier MCFE-xx							
		Nom.	Tol.	Nom.	Tol.	Nom.	Tol.	(Ref)	(Ref)	(Ref)	(Ref)	Radius	(Ref)	+05/-15 +0.02/-0.06	(Ref)			N/lb	N/lb	
MCFR 13	MCFR 13 S	13.000 .5118	+0/-0.050 +0/-0.002	9.000 0/-0.12 .3543 +0/-0.005	5.000 +0/-0.012 .1969 +0/-0.0005	13	.60	.024	7.5	.30	23	.9	500 19.7	N/A	N/A	N/A	2,060 463	1,650 371		
MCFR 13 B	MCFR 13 SB																			
MCFR 13 X	MCFR 13 SX		+0/-0.008 +0/-0.0003																	
MCFR 13 BX	MCFR 13 SBX																		Cylindrical	
MCF 16	MCF 16 S	16.000 .6299	+0/-0.050 +0/-0.002	11.000 0/-0.12 .4331 +0/-0.005	6.000 +0/-0.012 .2362 +0/-0.0005	16	.60	.024	9.0	.35	28	1.1	500 19.7	N/A	N/A	N/A	5,790 1,302	2,350 528		
MCF 16 B	MCF 16 SB																			
MCF 16 X	MCF 16 SX		+0/-0.008 +0/-0.0003																	
MCF 16 BX	MCF 16 SBX																		Cylindrical	
MCFE 16	MCFE 16 S	16.000 .6299	+0/-0.050 +0/-0.002	11.000 0/-0.12 .4331 +0/-0.005	6.000 +0/-0.012 .2362 +0/-0.0005	16	.60	.024	9.0	.35	28	1.1	500 19.7	0.5	.02	7	0.27	9	.35	
	MCFE 16 SB																			
	MCFE 16 SX		+0/-0.008 +0/-0.0003																	
	MCFE 16 SBX																			Cylindrical
MCFR 16	MCFR 16 S	16.000 .6299	+0/-0.050 +0/-0.002	11.000 0/-0.12 .4331 +0/-0.005	6.000 +0/-0.012 .2362 +0/-0.0005	16	.60	.024	9.0	.35	28	1.1	500 19.7	N/A	N/A	N/A	3,430 771	2,350 528		
MCFR 16 B	MCFR 16 SB																			
MCFR 16 X	MCFR 16 SX		+0/-0.008 +0/-0.0003																	
MCFR 16 BX	MCFR 16 SBX																		Cylindrical	
MCFRE 16	MCFRE 16 S	16.000 .6299	+0/-0.050 +0/-0.002	11.000 0/-0.12 .4331 +0/-0.005	6.000 +0/-0.012 .2362 +0/-0.0005	16	.60	.024	9.0	.35	28	1.1	500 19.7	0.5	.02	7	0.27	9	.35	
	MCFRE 16 SB																			
	MCFRE 16 SX		+0/-0.008 +0/-0.0003																	
	MCFRE 16 SBX																			Cylindrical
MCF 19	MCF 19 S	19.000 .7480	+0/-0.050 +0/-0.002	11.000 +0/-0.12 .4331 +0/-0.005	8.000 +0/-0.015 .3150 +0/-0.0006	20	.60	.024	11.0	.43	32	1.3	500 19.7	N/A	N/A	N/A	6,670 1,500	5,100 1,147		
MCF 19 B	MCF 19 SB																			
MCF 19 X	MCF 19 SX		+0/-0.009 +0/-0.0004																	
MCF 19 BX	MCF 19 SBX																		Cylindrical	
MCFE 19	MCFE 19 S	19.000 .7480	+0/-0.050 +0/-0.002	11.000 +0/-0.12 .4331 +0/-0.005	8.000 +0/-0.015 .3150 +0/-0.0006	20	.60	.024	11.0	.43	32	1.3	500 19.7	0.5	.02	9	0.35	11	.43	
	MCFE 19 SB																			
	MCFE 19 SX		+0/-0.009 +0/-0.0004																	
	MCFE 19 SBX																			Cylindrical
MCFR 19	MCFR 19 S	19.000 .7480	+0/-0.050 +0/-0.002	11.000 +0/-0.12 .4331 +0/-0.005	8.000 +0/-0.015 .3150 +0/-0.0006	20	.60	.024	11.0	.43	32	1.3	500 19.7	N/A	N/A	N/A	3,730 839	4,140 931		
MCFR 19 B	MCFR 19 SB																			
MCFR 19 X	MCFR 19 SX		+0/-0.009 +0/-0.0004																	
MCFR 19 BX	MCFR 19 SBX																		Cylindrical	
MCFRE 19	MCFRE 19 S	19.000 .7480	+0/-0.050 +0/-0.002	11.000 +0/-0.12 .4331 +0/-0.005	8.000 +0/-0.015 .3150 +0/-0.0006	20	.60	.024	11.0	.43	32	1.3	500 19.7	0.5	.02	9	0.35	11	.43	
	MCFRE 19 SB																			
	MCFRE 19 SX		+0/-0.009 +0/-0.0004																	
	MCFRE 19 SBX																			Cylindrical

1. Standard bearing has a crowned roller outside diameter. For straight cylindrical outside roller diameter, add suffix "X". Example - MCFR-35-X or MCF-35-SX.  
 2. Clamping torque is based on dry threads. If threads are lubricated, use half of value shown.  
 3. Static load rating is based on stud strength or on internal rolling element load distribution stresses.

Inch dimensions for reference only.

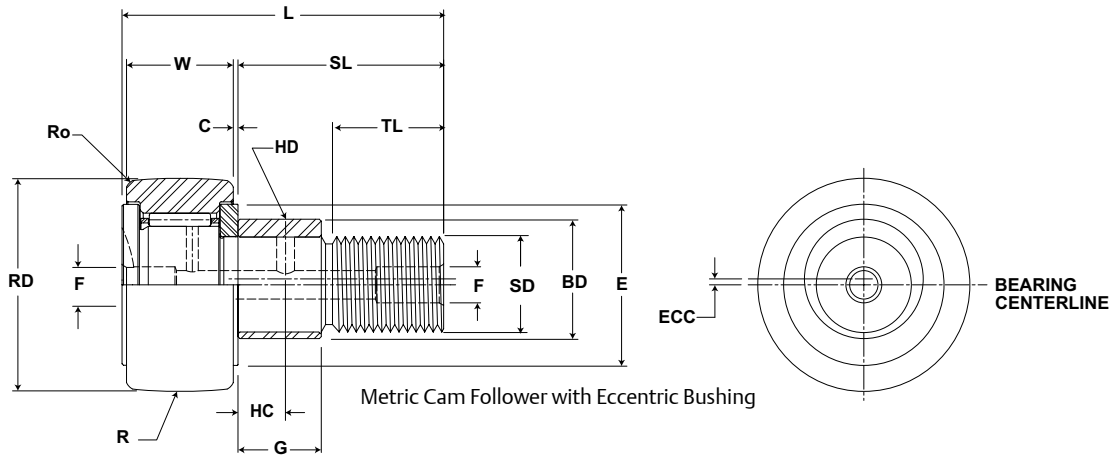

## MCF, MCFE

Part No.		HC	HD	F	H	Ro	E	Housing Bore Diameter		Thread Type	Clamping Torque	Limiting Speed (Grease)	WT
W/O Seals	With LUBRI-DISC Seals	Hole Center	Radial Lub. Hole Diameter	Lub. Hole Dia	Hex Hole Suffix MCF_xx B	Outer Corner	Min. Clamping Diameter						
		(Ref)	(Ref)	(Ref)	(Ref)	(Ref)	(Ref)	Nom.	Tol.				
MCFR 13	MCFR 13 S	-	-	3.1 .12	N/A	.3	9	5.000	+0.012/-0	M5x0.8	2.2 19	20,000	.01 .02
MCFR 13 B	MCFR 13 SB	-	-	-	3.1 .12	.01	.4	.1969	+0.0005/-0				
MCFR 13 X	MCFR 13 SX	-	-	3.1 .12	N/A								
MCFR 13 BX	MCFR 13 SBX	-	-	-	3.1 .12								
MCF 16	MCF 16 S	-	-	4 .16	N/A	.3	11	6.000	+0.012/-0	M6x1	3 27	13,000	.02 .04
MCF 16 B	MCF 16 SB	-	-	-	4 .16	.01	.4	.2362	+0.0005/-0				
MCF 16 X	MCF 16 SX	-	-	4 .16	N/A								
MCF 16 BX	MCF 16 SBX	-	-	-	4 .16								
MCFE 16	MCFE 16 S	-	-	4 .16	N/A	.3	11	11.050	+0.025/-0	M6x1	3 27	13,000	.02 .04
	MCFE 16 SB	-	-	-	4 .16	.01	.4	.4350	+0.0009/-0				
	MCFE 16 SX	-	-	4 .16	N/A								
	MCFE 16 SBX	-	-	-	4 .16								
MCFR 16	MCFR 16 S	-	-	4 .16	N/A	.3	11	6.000	+0.012/-0	M6x1	3 27	19,500	.02 .04
MCFR 16 B	MCFR 16 SB	-	-	-	4 .16	.01	.4	.2362	+0.0005/-0				
MCFR 16 X	MCFR 16 SX	-	-	4 .16	N/A								
MCFR 16 BX	MCFR 16 SBX	-	-	-	4 .16								
MCFRE 16	MCFRE 16 S	-	-	4 .16	N/A	.3	11	11.050	+0.012/-0	M6x1	3 27	19,500	.02 .04
	MCFRE 16 SB	-	-	-	4 .16	.01	.4	.4350	+0.0005/-0				
	MCFRE 16 SX	-	-	4 .16	N/A								
	MCFRE 16 SBX	-	-	-	4 .16								
MCF 19	MCF 19 S	-	-	4 .16	N/A	.3	13	8.000	+0.015/-0	M8x1.25	8 71	10,500	.03 .07
MCF 19 B	MCF 19 SB	-	-	-	4 .16	.01	.5	.3150	+0.0006/-0				
MCF 19 X	MCF 19 SX	-	-	4 .16	N/A								
MCF 19 BX	MCF 19 SBX	-	-	-	4 .16								
MCFE 19	MCFE 19 S	-	-	4 .16	N/A	.3	13	13.050	+0.025/-0	M8x1.25	8 71	10,500	.03 .07
	MCFE 19 SB	-	-	-	4 .16	.01	.5	.5138	+0.0009/-0				
	MCFE 19 SX	-	-	4 .16	N/A								
	MCFE 19 SBX	-	-	-	4 .16								
MCFR 19	MCFR 19 S	-	-	4 .16	N/A	.3	13	8.000	+0.015/-0	M8x1.25	8 71	15,500	.03 .07
MCFR 19 B	MCFR 19 SB	-	-	-	4 .16	.01	.5	.3150	+0.0006/-0				
MCFR 19 X	MCFR 19 SX	-	-	4 .16	N/A								
MCFR 19 BX	MCFR 19 SBX	-	-	-	4 .16								
MCFRE 19	MCFRE 19 S	-	-	4 .16	N/A	.3	13	13.050	+0.015/-0	M8x1.25	8 71	15,500	.03 .07
	MCFRE 19 SB	-	-	-	4 .16	.01	.5	.5138	+0.0006/-0				
	MCFRE 19 SX	-	-	4 .16	N/A								
	MCFRE 19 SBX	-	-	-	4 .16								

4. Dynamic load should not exceed 50% of Dynamic Rating as a track roller.

5. Since load, lubrication method, temperature and other factors affect the maximum operating speed, it is impossible to determine precise limiting speed. The listed limiting speeds are based on lightly loaded bearings having adequate lubrication and are listed only as a design guide. More frequent relubrication is required when operating at higher speeds. Actual bearing testing in the specific application should be conducted if the anticipated operating speed approaches the listed limiting speed.

\* Sizes 13 - 19 have no lube holes in the threaded end of the stud.

# MCGILL® Metric CAMROL Bearings



- Basic Construction Type:** Stud Type Crowned / Cylindrical Outside Diameter
- Rolling Elements:** Full Complement / Retained (Caged) Needle Roller
- Bearing Material:** Bearing Quality Steel
- Seal Type:** LUBRI-DISC®
- Lubrication:** Lithium Soap Grease NLGI #2
- System Configuration:** Concentric / Eccentric
- Mounting Feature:** Slot / Hex Hole

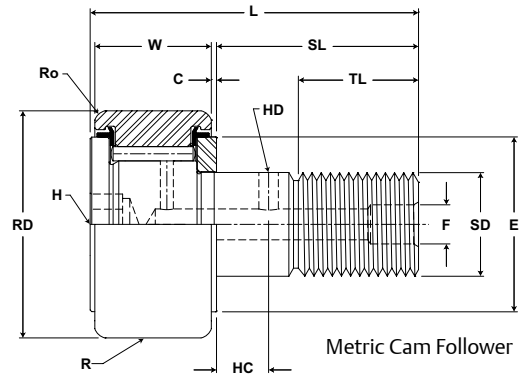

## MCF, MCCE

Part No.		RD		W		SD		SL	C	TL	L	R	ECC	G	BD	Track Roller Dynamic Rating	Track Roller Static Rating		
W/O Seals	With LUBRI-DISC Seals	Roller Diameter		Roller Width		Stud Diameter		Stud Length	Endplate Extension	Minimum Thread Length	Length Overall	Cylindrical	Eccentric						
		mm inch		mm inch		mm inch		mm inch	mm inch	mm inch	mm inch	mm inch	Base Modifier MCFE-xx						
		Nom.	Tol.	Nom.	Tol.	Nom.	Tol.	(Ref)	(Ref)	(Ref)	(Ref)	Radius	(Ref)	+05/- .15 + .002/- .006	(Ref)				
MCF 22	MCF 22 S	22.000 .8661	+0/- .050 +0/- .002	12.000 +0/- .12 .4724 +0/- .005	10.000 +0/- .015 .3937 +0/- .0006	23	.60	.024	12.0	.47	36	1.4	500 19.7	N/A	N/A	N/A	7,850 1,765	10,400 2,338	
MCF 22 B	MCF 22 SB																		
MCF 22 X	MCF 22 SX		+0/- .009 +0/- .0004																
MCF 22 BX	MCF 22 SBX																		Cylindrical
MCCE 22	MCCE 22 S	22.000 .8661	+0/- .050 +0/- .002	12.000 +0/- .12 .4724 +0/- .005	10.000 +0/- .015 .3937 +0/- .0006	23	.60	.024	12.0	.47	36	1.4	500 19.7	0.5	10	13	5,200 1,169	6,050 1,360	
	MCCE 22 SB																		
	MCCE 22 SX		+0/- .009 +0/- .0004																
	MCCE 22 SBX																		Cylindrical
MCCE 22	MCCE 22 S	22.000 .8661	+0/- .050 +0/- .002	12.000 +0/- .12 .4724 +0/- .005	10.000 +0/- .015 .3937 +0/- .0006	23	.60	.024	12.0	.47	36	1.4	500 19.7	N/A	N/A	N/A	5,200 1,169	6,050 1,360	
MCCE 22 B	MCCE 22 SB																		
MCCE 22 X	MCCE 22 SX		+0/- .009 +0/- .0004																
MCCE 22 BX	MCCE 22 SBX																		Cylindrical
MCFRE 22	MCFRE 22 S	22.000 .8661	+0/- .050 +0/- .002	12.000 +0/- .12 .4724 +0/- .005	10.000 +0/- .015 .3937 +0/- .0006	23	.60	.024	12.0	.47	36	1.4	500 19.7	0.5	10	13	5,200 1,169	6,050 1,360	
	MCFRE 22 SB																		
	MCFRE 22 SX		+0/- .009 +0/- .0004																
	MCFRE 22 SBX																		Cylindrical
MCF 22A	MCF 22A S	22.000 .8661	+0/- .050 +0/- .002	12.000 +0/- .12 .4724 +0/- .005	10.000 +0/- .015 .3937 +0/- .0006	23	.60	.024	13.0	.51	36	1.4	500 19.7	N/A	N/A	N/A	7,850 1,765	10,400 2,338	
MCF 22A B	MCF 22A SB																		
MCF 22A X	MCF 22A SX		+0/- .009 +0/- .0004																
MCF 22A BX	MCF 22A SBX																		Cylindrical
MCCE 22A	MCCE 22A S	22.000 .8661	+0/- .050 +0/- .002	12.000 +0/- .12 .4724 +0/- .005	10.000 +0/- .015 .3937 +0/- .0006	23	.60	.024	13.0	.51	36	1.4	500 19.7	0.5	10	13	5,200 1,169	6,050 1,360	
	MCCE 22A SB																		
	MCCE 22A SX		+0/- .009 +0/- .0004																
	MCCE 22A SBX																		Cylindrical
MCCE 22A	MCCE 22A S	22.000 .8661	+0/- .050 +0/- .002	12.000 +0/- .12 .4724 +0/- .005	10.000 +0/- .015 .3937 +0/- .0006	23	.60	.024	13.0	.51	36	1.4	500 19.7	N/A	N/A	N/A	5,200 1,169	6,050 1,360	
MCCE 22A B	MCCE 22A SB																		
MCCE 22A X	MCCE 22A SX		+0/- .009 +0/- .0004																
MCCE 22A BX	MCCE 22A SBX																		Cylindrical
MCFRE 22A	MCFRE 22A S	22.000 .8661	+0/- .050 +0/- .002	12.000 +0/- .12 .4724 +0/- .005	10.000 +0/- .015 .3937 +0/- .0006	23	.60	.024	13.0	.51	36	1.4	500 19.7	0.5	10	13	5,200 1,169	6,050 1,360	
	MCFRE 22A SB																		
	MCFRE 22A SX		+0/- .009 +0/- .0004																
	MCFRE 22A SBX																		Cylindrical

1. Standard bearing has a crowned roller outside diameter. For straight cylindrical outside roller diameter, add suffix "X". Example - MCFR-35-X or MCF-35-SX.  
 2. Clamping torque is based on dry threads. If threads are lubricated, use half of value shown.  
 3. Static load rating is based on stud strength or on internal rolling element load distribution stresses.  
 4. Dynamic load should not exceed 50% of Dynamic Rating as a track roller.  
 5. Since load, lubrication method, temperature and other factors affect the maximum operating speed, it is impossible to determine precise limiting speed. The listed limiting speeds are based on lightly loaded bearings having adequate lubrication and are listed only as a design guide. More frequent relubrication is required when operating at higher speeds. Actual bearing testing in the specific application should be conducted if the anticipated operating speed approaches the listed limiting speed.

Inch dimensions for reference only.  
 Not all parts are available from stock. Please contact customer service for availability (800) 626-2120.  
 For more information on bearing capabilities outside of our standard offering, please contact Application Engineering (800) 626-2093.

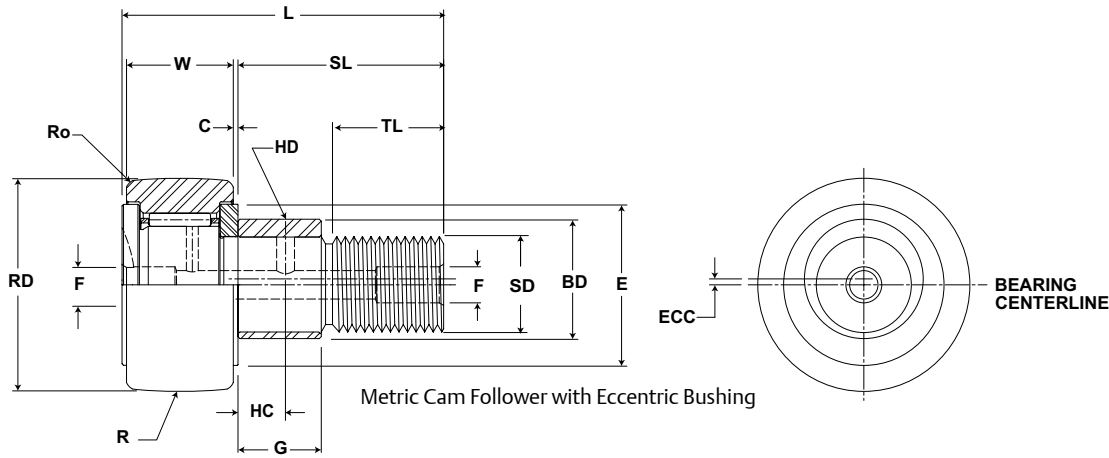

## MCF, MCFE

Part No.		HC	HD	F	H	Ro	E	Housing Bore Diameter		Thread Type	Clamping Torque	Limiting Speed (Grease)	WT
W/O Seals	With LUBRI-DISC Seals	Hole Center	Radial Lub. Hole Diameter	Lub. Hole Dia	Hex Hole Suffix MCF_xx B	Outer Corner	Min. Clamping Diameter						
		(Ref)	(Ref)	(Ref)	(Ref)	(Ref)	(Ref)	Nom.	Tol.				
MCF 22	MCF 22 S	-	-	.4 .16	N/A	.5	15	10.000	+.015/-0	M10x1	15 133	9,000	.04 .09
MCF 22 B	MCF 22 SB	-	-	-	.4 .16	.02	.6	.3937	+0.0006/-0				
MCF 22 X	MCF 22 SX	-	-	.4 .16	N/A								
MCF 22 BX	MCF 22 SBX	-	-	-	.4 .16								
MCFE 22	MCFE 22 S	-	-	.4 .16	N/A	.5	15	13.050	+0.025/-0	M10x1	15 133	9,000	.04 .09
MCFE 22 B	MCFE 22 SB	-	-	-	.4 .16	.02	.6	.5138	+0.0009/-0				
MCFE 22 X	MCFE 22 SX	-	-	.4 .16	N/A								
MCFE 22 BX	MCFE 22 SBX	-	-	-	.4 .16								
MCFR 22	MCFR 22 S	-	-	.4 .16	N/A	.5	15	10.000	+.015/-0	M10x1	15 133	13,500	.04 .09
MCFR 22 B	MCFR 22 SB	-	-	-	.4 .16	.02	.6	.3937	+0.0006/-0				
MCFR 22 X	MCFR 22 SX	-	-	.4 .16	N/A								
MCFR 22 BX	MCFR 22 SBX	-	-	-	.4 .16								
MCFRE 22	MCFRE 22 S	-	-	.4 .16	N/A	.5	15	13.050	+0.025/-0	M10x1	15 133	13,500	.04 .09
MCFRE 22 B	MCFRE 22 SB	-	-	-	.4 .16	.02	.6	.5138	+0.0009/-0				
MCFRE 22 X	MCFRE 22 SX	-	-	.4 .16	N/A								
MCFRE 22 BX	MCFRE 22 SBX	-	-	-	.4 .16								
MCF 22A	MCF 22A S	-	-	.4 .16	N/A	.5	15	10.000	+.015/-0	M10x1.25	15 133	9,000	.04 .09
MCF 22A B	MCF 22A SB	-	-	-	.5 .2	.02	.6	.3937	+0.0006/-0				
MCF 22A X	MCF 22A SX	-	-	.4 .16	N/A								
MCF 22A BX	MCF 22A SBX	-	-	-	.5 .2								
MCFE 22A	MCFE 22A S	-	-	.4 .16	N/A	.5	15	13.050	+0.025/-0	M10x1.25	15 133	9,000	.04 .09
MCFE 22A B	MCFE 22A SB	-	-	-	.5 .2	.02	.6	.5138	+0.0009/-0				
MCFE 22A X	MCFE 22A SX	-	-	.4 .16	N/A								
MCFE 22A BX	MCFE 22A SBX	-	-	-	.5 .2								
MCFR 22A	MCFR 22A S	-	-	.4 .16	N/A	.5	15	10.000	+.015/-0	M10x1.25	15 133	13,500	.04 .09
MCFR 22A B	MCFR 22A SB	-	-	-	.5 .2	.02	.6	.3937	+0.0006/-0				
MCFR 22A X	MCFR 22A SX	-	-	.4 .2	N/A								
MCFR 22A BX	MCFR 22A SBX	-	-	-	.5 .2								
MCFRE 22A	MCFRE 22A S	-	-	.4 .16	N/A	.5	15	13.050	+0.025/-0	M10x1.25	15 133	13,500	.04 .09
MCFRE 22A B	MCFRE 22A SB	-	-	-	.5 .2	.02	.6	.5138	+0.0009/-0				
MCFRE 22A X	MCFRE 22A SX	-	-	.4 .16	N/A								
MCFRE 22A BX	MCFRE 22A SBX	-	-	-	.5 .2								



# MCGILL® Metric CAMROL Bearings



- Basic Construction Type:** Stud Type Crowned / Cylindrical Outside Diameter
- Rolling Elements:** Full Complement / Retained (Caged) Needle Roller
- Bearing Material:** Bearing Quality Steel
- Seal Type:** LUBRI-DISC®
- Lubrication:** Lithium Soap Grease NLGI #2
- System Configuration:** Concentric / Eccentric
- Mounting Feature:** Slot / Hex Hole

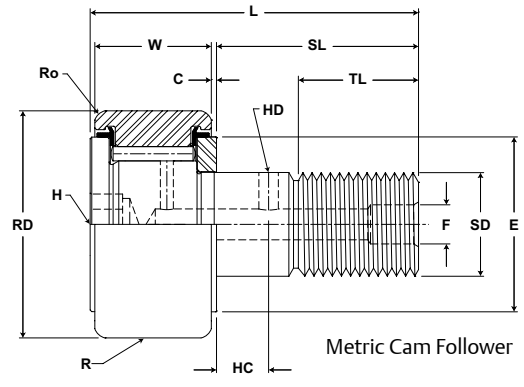

## MCF, MCFE

Part No.		RD		W		SD		SL	C	TL	L	R	ECC	G	BD	Track Roller Dynamic Rating	Track Roller Static Rating
W/O Seals	With LUBRI-DISC Seals	Roller Diameter		Roller Width		Stud Diameter		Stud Length	Endplate Extension	Minimum Thread Length	Length Overall	Cylindrical	Eccentric				
		mm inch		mm inch		mm inch		mm inch	mm inch	mm inch	mm inch	mm inch	Base Modifier MCFE-xx				
		Nom.	Tol.	Nom.	Tol.	Nom.	Tol.	(Ref)	(Ref)	(Ref)	(Ref)	Radius	(Ref)	+05/- .15 + .002/- .006	(Ref)		
MCF 26	MCF 26 S	26.000 1.0236	+0/- .050 +0/- .002	12.000 .4724	+0/- .12 +0/- .005	10.000 .3937	+0/- .015 +0/- .0006	23 .9	.60 .024	12.0 .47	36 1.4	500 19.7	N/A	N/A	N/A	7,850 1,765	10,400 2,338
MCF 26 B	MCF 26 SB		Cylindrical														
MCF 26 X	MCF 26 SX		Cylindrical														
MCF 26 BX	MCF 26 SBX		Cylindrical														
MCFE 26	MCFE 26 S	26.000 1.0236	+0/- .050 +0/- .002	12.000 .4724	+0/- .12 +0/- .005	10.000 .3937	+0/- .015 +0/- .0006	23 .9	.60 .024	12.0 .47	36 1.4	500 19.7	0.5 .02	10 0.39	13 .51	5,200 1,169	6,050 1,360
MCFE 26 B	MCFE 26 SB		Cylindrical														
MCFE 26 X	MCFE 26 SX		Cylindrical														
MCFE 26 BX	MCFE 26 SBX		Cylindrical														
MCFR 26	MCFR 26 S	26.000 1.0236	+0/- .050 +0/- .002	12.000 .4724	+0/- .12 +0/- .005	10.000 .3937	+0/- .015 +0/- .0006	23 .9	.60 .024	12.0 .47	36 1.4	500 19.7	N/A	N/A	N/A	5,200 1,169	6,050 1,360
MCFR 26 B	MCFR 26 SB		Cylindrical														
MCFR 26 X	MCFR 26 SX		Cylindrical														
MCFR 26 BX	MCFR 26 SBX		Cylindrical														
MCFRE 26	MCFRE 26 S	26.000 1.0236	+0/- .050 +0/- .002	12.000 .4724	+0/- .12 +0/- .005	10.000 .3937	+0/- .015 +0/- .0006	23 .9	.60 .024	12.0 .47	36 1.4	500 19.7	0.5 .02	10 0.39	13 .51	5,200 1,169	6,050 1,360
MCFRE 26 B	MCFRE 26 SB		Cylindrical														
MCFRE 26 X	MCFRE 26 SX		Cylindrical														
MCFRE 26 BX	MCFRE 26 SBX		Cylindrical														
MCF 26A	MCF 26A S	26.000 1.0236	+0/- .050 +0/- .002	12.000 .4724	+0/- .12 +0/- .005	10.000 .3937	+0/- .015 +0/- .0006	23 .9	.60 .024	13.0 .51	36 1.4	500 19.7	N/A	N/A	N/A	7,850 1,765	10,400 2,338
MCF 26A B	MCF 26A SB		Cylindrical														
MCF 26A X	MCF 26A SX		Cylindrical														
MCF 26A BX	MCF 26A SBX		Cylindrical														
MCFE 26A	MCFE 26A S	26.000 1.0236	+0/- .050 +0/- .002	12.000 .4724	+0/- .12 +0/- .005	10.000 .3937	+0/- .015 +0/- .0006	23 .9	.60 .024	13.0 .51	36 1.4	500 19.7	0.5 .02	10 0.39	13 .51	7,850 1,765	10,400 2,338
MCFE 26A B	MCFE 26A SB		Cylindrical														
MCFE 26A X	MCFE 26A SX		Cylindrical														
MCFE 26A BX	MCFE 26A SBX		Cylindrical														
MCFR 26A	MCFR 26A S	26.000 1.0236	+0/- .050 +0/- .002	12.000 .4724	+0/- .12 +0/- .005	10.000 .3937	+0/- .015 +0/- .0006	23 .9	.60 .024	13.0 .51	36 1.4	500 19.7	N/A	N/A	N/A	5,200 1,169	6,050 1,360
MCFR 26A B	MCFR 26A SB		Cylindrical														
MCFR 26A X	MCFR 26A SX		Cylindrical														
MCFR 26A BX	MCFR 26A SBX		Cylindrical														
MCFRE 26A	MCFRE 26A S	26.000 1.0236	+0/- .050 +0/- .002	12.000 .4724	+0/- .12 +0/- .005	10.000 .3937	+0/- .015 +0/- .0006	23 .9	.60 .024	13.0 .51	36 1.4	500 19.7	0.5 .02	10 0.39	13 .51	5,200 1,169	6,050 1,360
MCFRE 26A B	MCFRE 26A SB		Cylindrical														
MCFRE 26A X	MCFRE 26A SX		Cylindrical														
MCFRE 26A BX	MCFRE 26A SBX		Cylindrical														

1. Standard bearing has a crowned roller outside diameter. For straight cylindrical outside roller diameter, add suffix "X". Example - MCFR-35-X or MCF-35-SX.  
 2. Clamping torque is based on dry threads. If threads are lubricated, use half of value shown.  
 3. Static load rating is based on stud strength or on internal rolling element load distribution stresses.  
 4. Dynamic load should not exceed 50% of Dynamic Rating as a track roller.  
 5. Since load, lubrication method, temperature and other factors affect the maximum operating speed, it is impossible to determine precise limiting speed. The listed limiting speeds are based on lightly loaded bearings having adequate lubrication and are listed only as a design guide. More frequent relubrication is required when operating at higher speeds. Actual bearing testing in the specific application should be conducted if the anticipated operating speed approaches the listed limiting speed.

Inch dimensions for reference only.  
 Not all parts are available from stock. Please contact customer service for availability (800) 626-2120.  
 For more information on bearing capabilities outside of our standard offering, please contact Application Engineering (800) 626-2093.

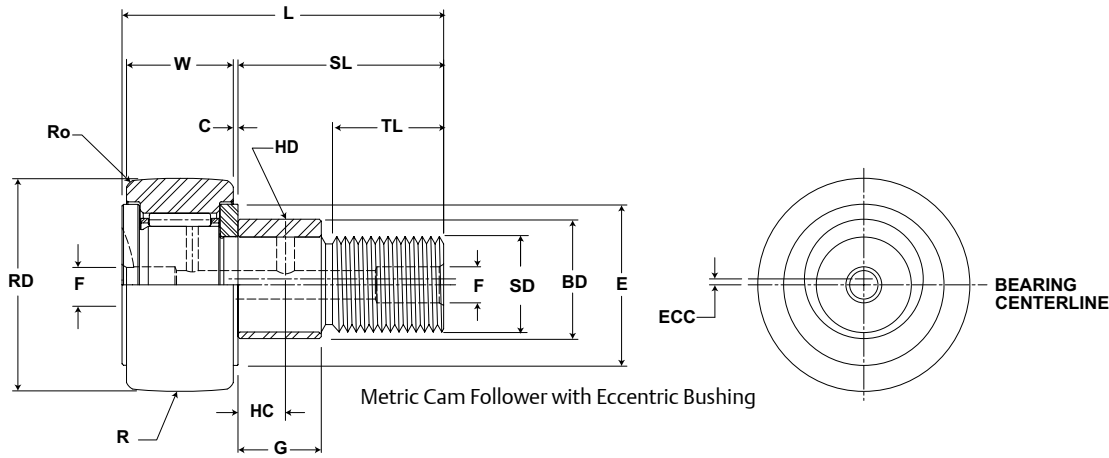

## MCF, MCFE

Part No.		HC	HD	F	H	Ro	E	Housing Bore Diameter		Thread Type	Clamping Torque	Limiting Speed (Grease)	WT
W/O Seals	With LUBRI-DISC Seals	Hole Center	Radial Lub. Hole Diameter	Lub. Hole Dia	Hex Hole Suffix MCF_xx B	Outer Corner	Min. Clamping Diameter						
		mm inch	mm inch	mm inch	mm inch	mm inch	mm inch						
		(Ref)	(Ref)	(Ref)	(Ref)	(Ref)	Nom.	Tol.	Nm in-lb	RPM	kg lb		
MCF 26	MCF 26 S	-	-	.4 .16	N/A	.5	15	10.000	+.015/-0	M10x1	15 133	9,000	.05 .11
MCF 26 B	MCF 26 SB	-	-	-	.4 .16	.02	.6	.3937	+0.0006/-0				
MCF 26 X	MCF 26 SX	-	-	.4 .16	N/A								
MCF 26 BX	MCF 26 SBX	-	-	-	.4 .16								
MCFE 26	MCFE 26 S	-	-	.4 .16	N/A	.5	15	13.050	+0.025/-0	M10x1	15 133	9,000	.05 .11
	MCFE 26 SB	-	-	-	.4 .16	.02	.6	.5138	+0.0009/-0				
	MCFE 26 SX	-	-	.4 .16	N/A								
	MCFE 26 SBX	-	-	-	.4 .16								
MCFR 26	MCFR 26 S	-	-	.4 .16	N/A	.5	15	10.000	+.015/-0	M10x1	15 133	13,500	.05 .11
MCFR 26 B	MCFR 26 SB	-	-	-	.4 .16	.02	.6	.3937	+0.0006/-0				
MCFR 26 X	MCFR 26 SX	-	-	.4 .16	N/A								
MCFR 26 BX	MCFR 26 SBX	-	-	-	.4 .16								
MCFRE 26	MCFRE 26 S	-	-	.4 .16	N/A	.5	15	13.050	+0.025/-0	M10x1	15 133	13,500	.05 .11
	MCFRE 26 SB	-	-	-	.4 .16	.02	.6	.5138	+0.0009/-0				
	MCFRE 26 SX	-	-	.4 .16	N/A								
	MCFRE 26 SBX	-	-	-	.4 .16								
MCF 26A	MCF 26A S	-	-	.4 .16	N/A	.5	19	10.000	+.015/-0	M10x1.25	22 195	9,000	.05 .11
MCF 26A B	MCF 26A SB	-	-	-	.5 .2	.02	.7	.3937	+0.0006/-0				
MCF 26A X	MCF 26A SX	-	-	.4 .16	N/A								
MCF 26A BX	MCF 26A SBX	-	-	-	.5 .2								
MCFE 26A	MCFE 26A S	-	-	.4 .16	N/A	.5	19	13.050	+0.025/-0	M10x1.25	22 195	9,000	.05 .11
	MCFE 26A SB	-	-	-	.5 .2	.02	.7	.5138	+0.0009/-0				
	MCFE 26A SX	-	-	.4 .16	N/A								
	MCFE 26A SBX	-	-	-	.5 .2								
MCFR 26A	MCFR 26A S	-	-	.4 .16	N/A	.5	19	10.000	+.015/-0	M10x1.25	22 195	13,500	.05 .11
MCFR 26A B	MCFR 26A SB	-	-	-	.5 .2	.02	.7	.3937	+0.0006/-0				
MCFR 26A X	MCFR 26A SX	-	-	.4 .16	N/A								
MCFR 26A BX	MCFR 26A SBX	-	-	-	.5 .2								
MCFRE 26A	MCFRE 26A S	-	-	.4 .16	N/A	.5	19	13.050	+0.025/-0	M10x1.25	22 195	13,500	.05 .11
	MCFRE 26A SB	-	-	-	.5 .2	.02	.7	.5138	+0.0009/-0				
	MCFRE 26A SX	-	-	.4 .16	N/A								
	MCFRE 26A SBX	-	-	-	.5 .2								

# MCGILL® Metric CAMROL Bearings



- Basic Construction Type:** Stud Type Crowned / Cylindrical Outside Diameter
- Rolling Elements:** Full Complement / Retained (Caged) Needle Roller
- Bearing Material:** Bearing Quality Steel
- Seal Type:** LUBRI-DISC®
- Lubrication:** Lithium Soap Grease NLGI #2
- System Configuration:** Concentric / Eccentric
- Mounting Feature:** Slot / Hex Hole

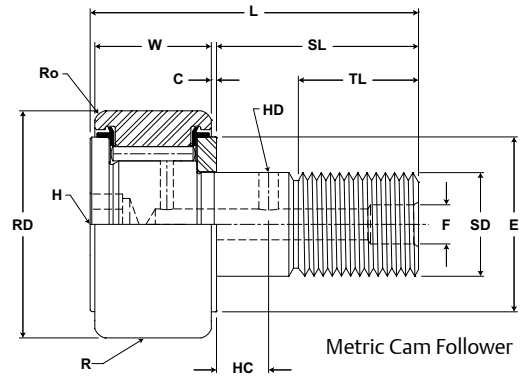

## MCF, MCFE

Part No.		RD		W		SD		SL	C	TL	L	R	ECC	G	BD	Track Roller Dynamic Rating	Track Roller Static Rating
W/O Seals	With LUBRI-DISC Seals	Roller Diameter		Roller Width		Stud Diameter		Stud Length	Endplate Extension	Minimum Thread Length	Length Overall	Cylindrical	Eccentric				
		mm inch		mm inch		mm inch		mm inch	mm inch	mm inch	mm inch	mm inch	Base Modifier MCFE-xx				
		Nom.	Tol.	Nom.	Tol.	Nom.	Tol.	(Ref)	(Ref)	(Ref)	(Ref)	Radius	(Ref)	+05/- .15 +0.02/- .006	(Ref)		
MCF 30	MCF 30 S	30.000 1.1811	+0/- .050 +0/- .002	14.000 +0/- .12 .5512 +0/- .005	12.000 +0/- .018 .4724 +0/- .0007	25 .9	.60 .024	14.0 .55	40 1.6	500 19.7	Cylindrical	N/A	N/A	N/A	11,080 2,491	15,300 3,440	
MCF 30 B	MCF 30 SB																
MCF 30 X	MCF 30 SX																
MCF 30 BX	MCF 30 SBX																
MCFE 30	MCFE 30 S	30.000 1.1811	+0/- .050 +0/- .002	14.000 +0/- .12 .5512 +0/- .005	12.000 +0/- .018 .4724 +0/- .0007	25 .9	.60 .024	14.0 .55	40 1.6	500 19.7	Cylindrical	0.5 .02	11 0.43	15 .59	6,860 1,542	8,050 1,810	
MCFE 30 B	MCFE 30 SB																
MCFE 30 X	MCFE 30 SX																
MCFE 30 BX	MCFE 30 SBX																
MCFRE 30	MCFRE 30 S	30.000 1.1811	+0/- .050 +0/- .002	14.000 +0/- .12 .5512 +0/- .005	12.000 +0/- .018 .4724 +0/- .0007	25 .9	.60 .024	14.0 .55	40 1.6	500 19.7	Cylindrical	0.5 .02	11 0.43	15 .59	6,860 1,542	8,050 1,810	
MCFRE 30 B	MCFRE 30 SB																
MCFRE 30 X	MCFRE 30 SX																
MCFRE 30 BX	MCFRE 30 SBX																
MCF 32	MCF 32 S	32.000 1.2598	+0/- .050 +0/- .002	14.000 +0/- .12 .5512 +0/- .005	12.000 +0/- .018 .4724 +0/- .0007	25 .9	.60 .024	14.0 .55	40 1.6	500 19.7	Cylindrical	N/A	N/A	N/A	11,080 2,491	15,300 3,440	
MCF 32 B	MCF 32 SB																
MCF 32 X	MCF 32 SX																
MCF 32 BX	MCF 32 SBX																
MCFE 32	MCFE 32 S	32.000 1.2598	+0/- .050 +0/- .002	14.000 +0/- .12 .5512 +0/- .005	12.000 +0/- .018 .4724 +0/- .0007	25 .9	.60 .024	14.0 .55	40 1.6	500 19.7	Cylindrical	0.5 .02	11 0.43	15 .59	6,860 1,542	8,050 1,810	
MCFE 32 B	MCFE 32 SB																
MCFE 32 X	MCFE 32 SX																
MCFE 32 BX	MCFE 32 SBX																
MCFRE 32	MCFRE 32 S	32.000 1.2598	+0/- .050 +0/- .002	14.000 +0/- .12 .5512 +0/- .005	12.000 +0/- .018 .4724 +0/- .0007	25 .9	.60 .024	14.0 .55	40 1.6	500 19.7	Cylindrical	0.5 .02	11 0.43	15 .59	6,860 1,542	8,050 1,810	
MCFRE 32 B	MCFRE 32 SB																
MCFRE 32 X	MCFRE 32 SX																
MCFRE 32 BX	MCFRE 32 SBX																

1. Standard bearing has a crowned roller outside diameter. For straight cylindrical outside roller diameter, add suffix "X". Example - MCFR-35-X or MCF-35-SX.  
 2. Clamping torque is based on dry threads. If threads are lubricated, use half of value shown.  
 3. Static load rating is based on stud strength or on internal rolling element load distribution stresses.  
 4. Dynamic load should not exceed 50% of Dynamic Rating as a track roller.  
 5. Since load, lubrication method, temperature and other factors affect the maximum operating speed, it is impossible to determine precise limiting speed. The listed limiting speeds are based on lightly loaded bearings having adequate lubrication and are listed only as a design guide. More frequent relubrication is required when operating at higher speeds. Actual bearing testing in the specific application should be conducted if the anticipated operating speed approaches the listed limiting speed.

Inch dimensions for reference only.  
 Not all parts are available from stock. Please contact customer service for availability (800) 626-2120.  
 For more information on bearing capabilities outside of our standard offering, please contact Application Engineering (800) 626-2093.

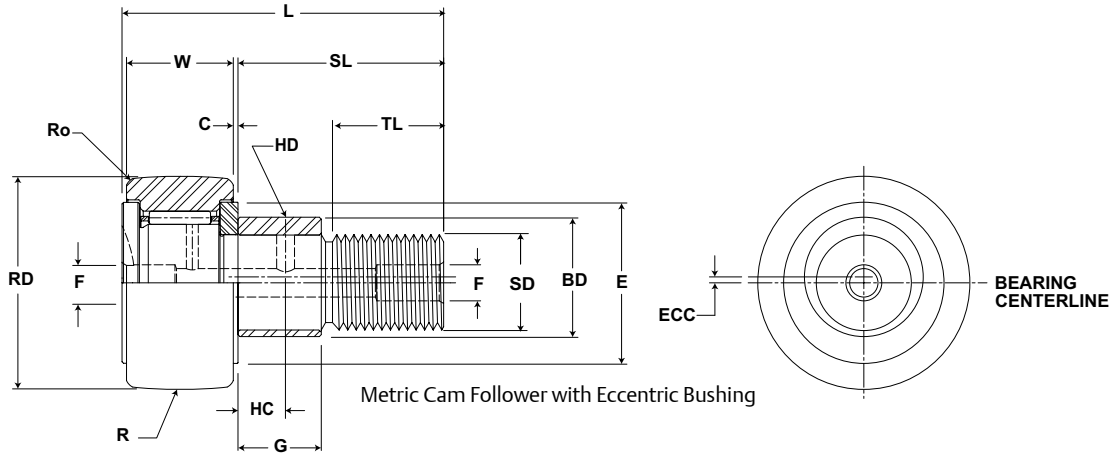

## MCF, MCFE

Part No.		HC	HD	F	H	Ro	E	Housing Bore Diameter		Thread Type	Clamping Torque	Limiting Speed (Grease)	WT
W/O Seals	With LUBRI-DISC Seals	Hole Center	Radial Lub. Hole Diameter	Lub. Hole Dia	Hex Hole Suffix MCF_xx B	Outer Corner	Min. Clamping Diameter						
		(Ref)	(Ref)	(Ref)	(Ref)	(Ref)	(Ref)	Nom.	Tol.				
MCF 30	MCF 30 S	6 .236	3 .118	6 .24	N/A	1.0 .04	19 .7	12.000 .4724	+0.018/-0 +0.0007/-0	M12x1.5	22 195	6,400	.09 .20
MCF 30 B	MCF 30 SB			-	6 .24								
MCF 30 X	MCF 30 SX			6 .24	N/A								
MCF 30 BX	MCF 30 SBX			-	6 .24								
MCFE 30	MCFE 30 S	N/A	N/A	6 .24	N/A	1.0 .04	19 .7	15.050 .5925	+0.025/-0 +0.0009/-0	M12x1.5	22 195	6,400	.09 .20
	MCFE 30 SB			-	6 .24								
	MCFE 30 SX			6 .24	N/A								
	MCFE 30 SBX			-	6 .24								
MCFR 30	MCFR 30 S	6 .236	3 .118	6 .24	N/A	1.0 .04	19 .7	12.000 .4724	+0.018/-0 +0.0007/-0	M12x1.5	22 195	9,600	.09 .20
MCFR 30 B	MCFR 30 SB			-	6 .24								
MCFR 30 X	MCFR 30 SX			6 .24	N/A								
MCFR 30 BX	MCFR 30 SBX			-	6 .24								
MCFRE 30	MCFRE 30 S	N/A	N/A	6 .24	N/A	1.0 .04	19 .7	15.050 .5925	+0.025/-0 +0.0009/-0	M12x1.5	22 195	9,600	.09 .20
	MCFRE 30 SB			-	6 .24								
	MCFRE 30 SX			6 .24	N/A								
	MCFRE 30 SBX			-	6 .24								
MCF 32	MCF 32 S	6 .236	3 .118	6 .24	N/A	1.0 .04	21 .8	12.000 .4724	+0.018/-0 +0.0007/-0	M12x1.5	57 504	6,400	.10 .22
MCF 32 B	MCF 32 SB			-	6 .24								
MCF 32 X	MCF 32 SX			6 .24	N/A								
MCF 32 BX	MCF 32 SBX			-	6 .24								
MCFE 32	MCFE 32 S	N/A	N/A	6 .24	N/A	1.0 .04	21 .8	15.050 .5925	+0.025/-0 +0.0009/-0	M12x1.5	57 504	6,400	.10 .22
	MCFE 32 SB			-	6 .24								
	MCFE 32 SX			6 .24	N/A								
	MCFE 32 SBX			-	6 .24								
MCFR 32	MCFR 32 S	6 .236	3 .118	6 .24	N/A	1.0 .04	21 .8	12.000 .4724	+0.018/-0 +0.0007/-0	M12x1.5	57 504	9,600	.10 .22
MCFR 32 B	MCFR 32 SB			-	6 .24								
MCFR 32 X	MCFR 32 SX			6 .24	N/A								
MCFR 32 BX	MCFR 32 SBX			-	6 .24								
MCFRE 32	MCFRE 32 S	N/A	N/A	6 .24	N/A	1.0 .04	21 .8	15.050 .5925	+0.025/-0 +0.0009/-0	M12x1.5	57 504	9,600	.10 .22
	MCFRE 32 SB			-	6 .24								
	MCFRE 32 SX			6 .24	N/A								
	MCFRE 32 SBX			-	6 .24								

# MCGILL® Metric CAMROL Bearings



- Basic Construction Type:** Stud Type Crowned / Cylindrical Outside Diameter
- Rolling Elements:** Full Complement / Retained (Caged) Needle Roller
- Bearing Material:** Bearing Quality Steel
- Seal Type:** LUBRI-DISC®
- Lubrication:** Lithium Soap Grease NLGI #2
- System Configuration:** Concentric / Eccentric
- Mounting Feature:** Slot / Hex Hole

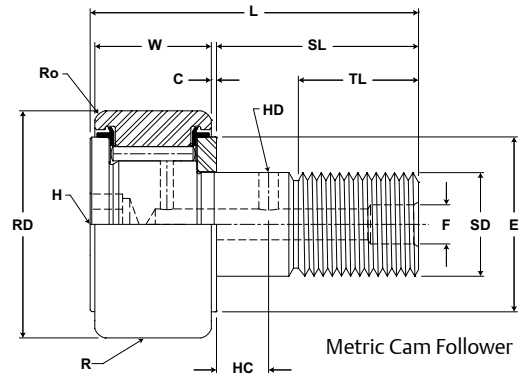

## MCF, MCCE

Part No.		RD		W		SD		SL	C	TL	L	R	ECC	G	BD	Track Roller Dynamic Rating	Track Roller Static Rating
W/O Seals	With LUBRI-DISC Seals	Roller Diameter		Roller Width		Stud Diameter		Stud Length	Endplate Extension	Minimum Thread Length	Length Overall	Cylindrical	Eccentric				
		mm inch		mm inch		mm inch		mm inch	mm inch	mm inch	mm inch	mm inch	Base Modifier MCFE-xx				
		Nom.	Tol.	Nom.	Tol.	Nom.	Tol.	(Ref)	(Ref)	(Ref)	(Ref)	Radius	(Ref)	+05/-15 +002/-006	(Ref)	N/lb	N/lb
MCF 35	MCF 35 S	35.000 1.3780	+0/-0.050 +0/-0.002	18.000 .7087	+0/-0.12 +0/-0.005	16.000 .6299	+0/-0.018 +0/-0.0007	33 1.3	.80 .031	18.0 .71	52 2.0	500 19.7	N/A	N/A	N/A	16,970 3,815	28,500 6,407
MCF 35 B	MCF 35 SB		Cylindrical														
MCF 35 X	MCF 35 SX																
MCF 35 BX	MCF 35 SBX																
MCCE 35	MCCE 35 S	35.000 1.3780	+0/-0.050 +0/-0.002	18.000 .7087	+0/-0.12 +0/-0.005	16.000 .6299	+0/-0.018 +0/-0.0007	33 1.3	.80 .031	18.0 .71	52 2.0	500 19.7	0.5 .02	14 0.55	20 .79	16,970 3,815	28,500 6,407
MCCE 35 B	MCCE 35 SB		Cylindrical														
MCCE 35 X	MCCE 35 SX																
MCCE 35 BX	MCCE 35 SBX																
MCCE 35	MCCE 35 S	35.000 1.3780	+0/-0.050 +0/-0.002	18.000 .7087	+0/-0.12 +0/-0.005	16.000 .6299	+0/-0.018 +0/-0.0007	33 1.3	.80 .031	18.0 .71	52 2.0	500 19.7	N/A	N/A	N/A	10,890 2,448	15,900 3,575
MCCE 35 B	MCCE 35 SB		Cylindrical														
MCCE 35 X	MCCE 35 SX																
MCCE 35 BX	MCCE 35 SBX																
MCFRE 35	MCFRE 35 S	35.000 1.3780	+0/-0.050 +0/-0.002	18.000 .7087	+0/-0.12 +0/-0.005	16.000 .6299	+0/-0.018 +0/-0.0007	33 1.3	.80 .031	18.0 .71	52 2.0	500 19.7	0.5 .02	14 0.55	20 .79	10,890 2,448	15,900 3,575
MCFRE 35 B	MCFRE 35 SB		Cylindrical														
MCFRE 35 X	MCFRE 35 SX																
MCFRE 35 BX	MCFRE 35 SBX																
MCF 40	MCF 40 S	40.000 1.5748	+0/-0.050 +0/-0.002	20.000 .7874	+0/-0.12 +0/-0.005	18.000 .7087	+0/-0.018 +0/-0.0007	37 1.4	.80 .031	19.0 .75	58 2.3	500 19.7	N/A	N/A	N/A	19,420 4,366	32,200 7,239
MCF 40 B	MCF 40 SB		Cylindrical														
MCF 40 X	MCF 40 SX																
MCF 40 BX	MCF 40 SBX																
MCCE 40	MCCE 40 S	40.000 1.5748	+0/-0.050 +0/-0.002	20.000 .7874	+0/-0.12 +0/-0.005	18.000 .7087	+0/-0.018 +0/-0.0007	37 1.4	.80 .031	19.0 .75	58 2.3	500 19.7	1 .04	16 0.63	22 .87	19,420 4,366	32,200 7,239
MCCE 40 B	MCCE 40 SB		Cylindrical														
MCCE 40 X	MCCE 40 SX																
MCCE 40 BX	MCCE 40 SBX																
MCFR 40	MCFR 40 S	40.000 1.5748	+0/-0.050 +0/-0.002	20.000 .7874	+0/-0.12 +0/-0.005	18.000 .7087	+0/-0.018 +0/-0.0007	37 1.4	.80 .031	19.0 .75	58 2.3	500 19.7	N/A	N/A	N/A	13,340 2,999	19,800 4,451
MCFR 40 B	MCFR 40 SB		Cylindrical														
MCFR 40 X	MCFR 40 SX																
MCFR 40 BX	MCFR 40 SBX																
MCFRE 40	MCFRE 40 S	40.000 1.5748	+0/-0.050 +0/-0.002	20.000 .7874	+0/-0.12 +0/-0.005	18.000 .7087	+0/-0.018 +0/-0.0007	37 1.4	.80 .031	19.0 .75	58 2.3	500 19.7	1 .04	16 0.63	22 .87	13,340 2,999	19,800 4,451
MCFRE 40 B	MCFRE 40 SB		Cylindrical														
MCFRE 40 X	MCFRE 40 SX																
MCFRE 40 BX	MCFRE 40 SBX																

1. Standard bearing has a crowned roller outside diameter. For straight cylindrical outside roller diameter, add suffix "X". Example - MCFR-35-X or MCF-35-SX.  
 2. Clamping torque is based on dry threads. If threads are lubricated, use half of value shown.  
 3. Static load rating is based on stud strength or on internal rolling element load distribution stresses.  
 4. Dynamic load should not exceed 50% of Dynamic Rating as a track roller.  
 5. Since load, lubrication method, temperature and other factors affect the maximum operating speed, it is impossible to determine precise limiting speed. The listed limiting speeds are based on lightly loaded bearings having adequate lubrication and are listed only as a design guide. More frequent relubrication is required when operating at higher speeds. Actual bearing testing in the specific application should be conducted if the anticipated operating speed approaches the listed limiting speed.

Inch dimensions for reference only.  
 Not all parts are available from stock. Please contact customer service for availability (800) 626-2120.  
 For more information on bearing capabilities outside of our standard offering, please contact Application Engineering (800) 626-2093.

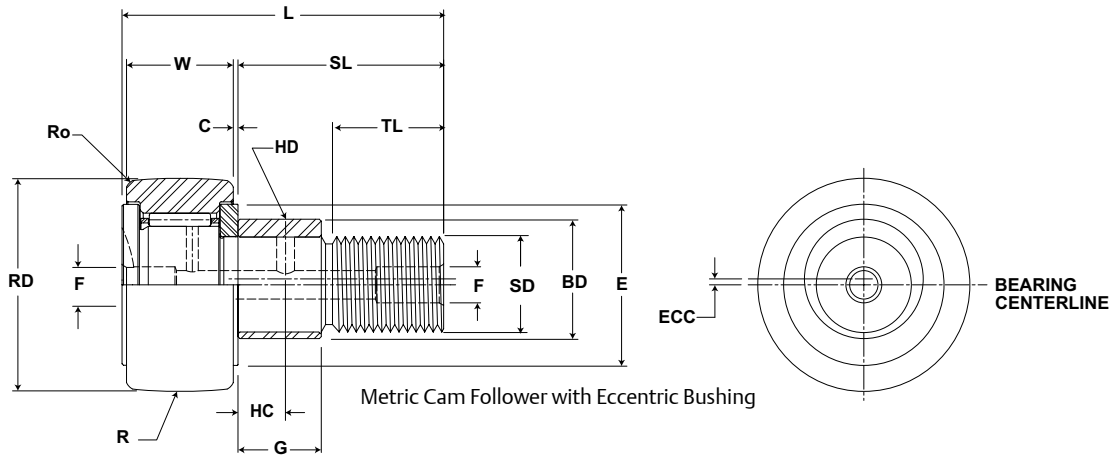

## MCF, MCFE

Part No.		HC	HD	F	H	Ro	E	Housing Bore Diameter		Thread Type	Clamping Torque	Limiting Speed (Grease)	WT		
W/O Seals	With LUBRI-DISC Seals	Hole Center	Radial Lub. Hole Diameter	Lub. Hole Dia	Hex Hole Suffix MCF_xx B	Outer Corner	Min. Clamping Diameter							Nm in-lb	RPM
		(Ref)	(Ref)	(Ref)	(Ref)	(Ref)	(Ref)	Nom.	Tol.						
MCF 35	MCF 35 S	.315	.118	6/24	N/A	1.0	24	16.000	+.018/-0	M16x1.5	85	4,200	.16		
MCF 35 B	MCF 35 SB			-	8/31									.6299	+0.0007/-0
MCF 35 X	MCF 35 SX			6/24	N/A										
MCF 35 BX	MCF 35 SBX			-	8/31										
MCFE 35	MCFE 35 S	N/A	N/A	6/24	N/A	1.0	24	20.050	+0.025/-0	M16x1.5	85	4,200	.16		
MCFE 35 B	MCFE 35 SB			-	8/31									.7894	+0.0009/-0
MCFE 35 X	MCFE 35 SX			6/24	N/A										
MCFE 35 BX	MCFE 35 SBX			-	8/31										
MCFR 35	MCFR 35 S	.315	.118	6/24	N/A	1.0	24	16.000	+.018/-0	M16x1.5	85	6,300	.16		
MCFR 35 B	MCFR 35 SB			-	8/31									.6299	+0.0007/-0
MCFR 35 X	MCFR 35 SX			6/24	N/A										
MCFR 35 BX	MCFR 35 SBX			-	8/31										
MCFRE 35	MCFRE 35 S	N/A	N/A	6/24	N/A	1.0	24	20.050	+0.025/-0	M16x1.5	85	6,300	.16		
MCFRE 35 B	MCFRE 35 SB			-	8/31									.7894	+0.0009/-0
MCFRE 35 X	MCFRE 35 SX			6/24	N/A										
MCFRE 35 BX	MCFRE 35 SBX			-	8/31										
MCF 40	MCF 40 S	.315	.118	6/24	N/A	1.5	27	18.000	+.018/-0	M18x1.5	85	3,300	.25		
MCF 40 B	MCF 40 SB			-	8/31									.7087	+0.0007/-0
MCF 40 X	MCF 40 SX			6/24	N/A										
MCF 40 BX	MCF 40 SBX			-	8/31										
MCFE 40	MCFE 40 S	N/A	N/A	6/24	N/A	1.5	27	22.050	+0.025/-0	M18x1.5	85	3,300	.25		
MCFE 40 B	MCFE 40 SB			-	8/31									.8681	+0.0009/-0
MCFE 40 X	MCFE 40 SX			6/24	N/A										
MCFE 40 BX	MCFE 40 SBX			-	8/31										
MCFR 40	MCFR 40 S	.315	.118	6/24	N/A	1.5	27	18.000	+.018/-0	M18x1.5	85	5,000	.25		
MCFR 40 B	MCFR 40 SB			-	8/31									.7087	+0.0007/-0
MCFR 40 X	MCFR 40 SX			6/24	N/A										
MCFR 40 BX	MCFR 40 SBX			-	8/31										
MCFRE 40	MCFRE 40 S	N/A	N/A	6/24	N/A	1.5	27	22.050	+0.025/-0	M18x1.5	85	5,000	.25		
MCFRE 40 B	MCFRE 40 SB			-	8/31									.8681	+0.0009/-0
MCFRE 40 X	MCFRE 40 SX			6/24	N/A										
MCFRE 40 BX	MCFRE 40 SBX			-	8/31										

# MCGILL® Metric CAMROL Bearings



- Basic Construction Type:** Stud Type Crowned / Cylindrical Outside Diameter
- Rolling Elements:** Full Complement / Retained (Caged) Needle Roller
- Bearing Material:** Bearing Quality Steel
- Seal Type:** LUBRI-DISC®
- Lubrication:** Lithium Soap Grease NLGI #2
- System Configuration:** Concentric / Eccentric
- Mounting Feature:** Slot / Hex Hole

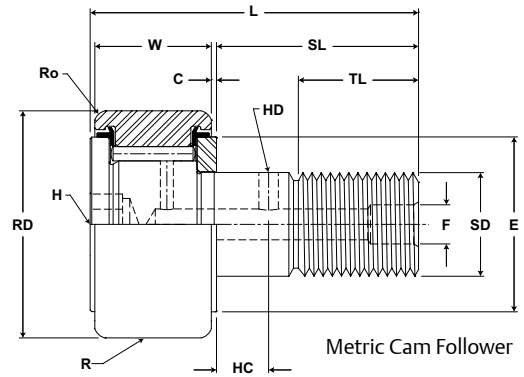

## MCF, MCFE

Part No.		RD		W		SD		SL	C	TL	L	R	ECC	G	BD	Track Roller Dynamic Rating	Track Roller Static Rating
W/O Seals	With LUBRI-DISC Seals	Roller Diameter		Roller Width		Stud Diameter		Stud Length	Endplate Extension	Minimum Thread Length	Length Overall	Cylindrical	Eccentric				
		mm inch		mm inch		mm inch		mm inch	mm inch	mm inch	mm inch	mm inch	Base Modifier MCFE-xx				
		Nom.	Tol.	Nom.	Tol.	Nom.	Tol.	(Ref)	(Ref)	(Ref)	(Ref)	Radius	(Ref)	+05/- .15 + .002/- .006	(Ref)		
MCF 40A	MCF 40A S	40.000 1.5748	+0/- .050 +0/- .002	20.000 +0/- .12 .7874 +0/- .005	18.000 +0/- .018 .7087 +0/- .0007	37 1.4	.80 .031	20.0 .79	58 2.3	500 19.7	Cylindrical	N/A	N/A	N/A	19,420 4,366	32,200 7,239	
MCF 40A B	MCF 40A SB																
MCF 40A X	MCF 40A SX																
MCF 40A BX	MCF 40A SBX																
MCFE 40A	MCFE 40A S	40.000 1.5748	+0/- .050 +0/- .002	20.000 +0/- .12 .7874 +0/- .005	18.000 +0/- .018 .7087 +0/- .0007	37 1.4	.80 .031	20.0 .79	58 2.3	500 19.7	Cylindrical	1 .04	16 0.63	22 .87	13,340 2,999	19,800 4,451	
MCFE 40A B	MCFE 40A SB																
MCFE 40A X	MCFE 40A SX																
MCFE 40A BX	MCFE 40A SBX																
MCFRE 40A	MCFRE 40A S	40.000 1.5748	+0/- .050 +0/- .002	20.000 +0/- .12 .7874 +0/- .005	18.000 +0/- .018 .7087 +0/- .0007	37 1.4	.80 .031	20.0 .79	58 2.3	500 19.7	Cylindrical	1 .04	16 0.63	22 .87	17,750 3,991	29,800 6,700	
MCFRE 40A B	MCFRE 40A SB																
MCFRE 40A X	MCFRE 40A SX																
MCFRE 40A BX	MCFRE 40A SBX																
MCF 47	MCF 47 S	47.000 1.8504	+0/- .050 +0/- .002	24.000 +0/- .12 .9449 +0/- .005	20.000 +0/- .021 .7874 +0/- .0008	41 1.6	.80 .031	21.0 .83	66 2.6	500 19.7	Cylindrical	N/A	N/A	N/A	25,690 5,776	46,700 10,499	
MCF 47 B	MCF 47 SB																
MCF 47 X	MCF 47 SX																
MCF 47 BX	MCF 47 SBX																
MCFE 47	MCFE 47 S	47.000 1.8504	+0/- .050 +0/- .002	24.000 +0/- .12 .9449 +0/- .005	20.000 +0/- .021 .7874 +0/- .0008	41 1.6	.80 .031	21.0 .83	66 2.6	500 19.7	Cylindrical	1 .04	18 0.71	24 .94	17,750 3,991	29,800 6,700	
MCFE 47 B	MCFE 47 SB																
MCFE 47 X	MCFE 47 SX																
MCFE 47 BX	MCFE 47 SBX																
MCFRE 47	MCFRE 47 S	47.000 1.8504	+0/- .050 +0/- .002	24.000 +0/- .12 .9449 +0/- .005	20.000 +0/- .021 .7874 +0/- .0008	41 1.6	.80 .031	21.0 .83	66 2.6	500 19.7	Cylindrical	1 .04	18 0.71	24 .94	17,750 3,991	29,800 6,700	
MCFRE 47 B	MCFRE 47 SB																
MCFRE 47 X	MCFRE 47 SX																
MCFRE 47 BX	MCFRE 47 SBX																

1. Standard bearing has a crowned roller outside diameter. For straight cylindrical outside roller diameter, add suffix "X". Example - MCFR-35-X or MCF-35-SX.  
 2. Clamping torque is based on dry threads. If threads are lubricated, use half of value shown.  
 3. Static load rating is based on stud strength or on internal rolling element load distribution stresses.  
 4. Dynamic load should not exceed 50% of Dynamic Rating as a track roller.  
 5. Since load, lubrication method, temperature and other factors affect the maximum operating speed, it is impossible to determine precise limiting speed. The listed limiting speeds are based on lightly loaded bearings having adequate lubrication and are listed only as a design guide. More frequent relubrication is required when operating at higher speeds. Actual bearing testing in the specific application should be conducted if the anticipated operating speed approaches the listed limiting speed.

Inch dimensions for reference only.  
 Not all parts are available from stock. Please contact customer service for availability (800) 626-2120.  
 For more information on bearing capabilities outside of our standard offering, please contact Application Engineering (800) 626-2093.

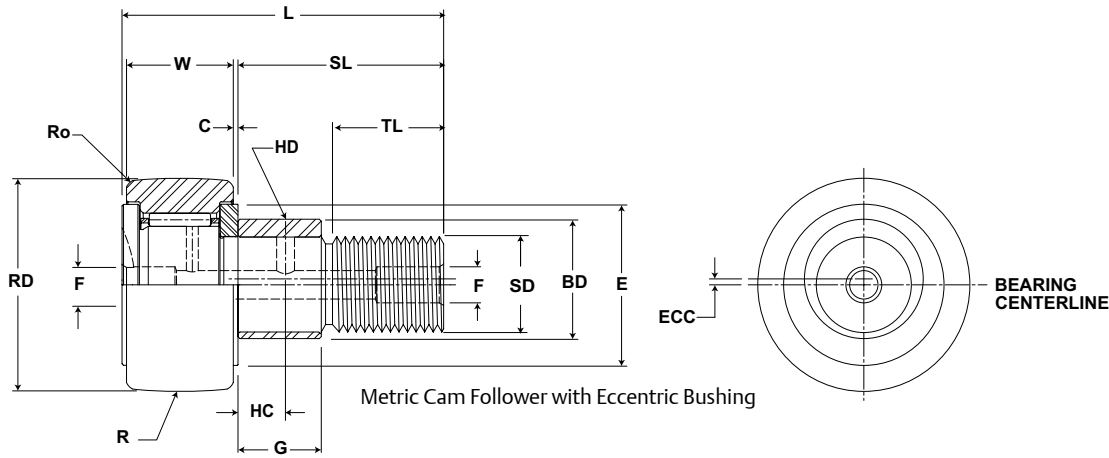

## MCF, MCFE

Part No.		HC	HD	F	H	Ro	E	Housing Bore Diameter		Thread Type	Clamping Torque	Limiting Speed (Grease)	WT
W/O Seals	With LUBRI-DISC Seals	Hole Center	Radial Lub. Hole Diameter	Lub. Hole Dia	Hex Hole Suffix MCF_xx B	Outer Corner	Min. Clamping Diameter						
		(Ref)	(Ref)	(Ref)	(Ref)	(Ref)	(Ref)	Nom.	Tol.				
MCF 40A	MCF 40A S			$\frac{6}{24}$	N/A					M18x1.5	118 1,044	3,300	.25 .55
MCF 40A B	MCF 40A SB	10	3	-	$\frac{8}{31}$	1.5	27	18.000	+0.018/-0				
MCF 40A X	MCF 40A SX	.394	.118	$\frac{6}{24}$	N/A	.06	1.1	.7087	+0.0007/-0				
MCF 40A BX	MCF 40A SBX			-	$\frac{8}{31}$								
MCFE 40A	MCFE 40A S			$\frac{6}{24}$	N/A					M18x1.5	118 1,044	3,300	.25 .55
	MCFE 40A SB	N/A	N/A	-	$\frac{8}{31}$	1.5	27	22.050	+0.025/-0				
	MCFE 40A SX			$\frac{6}{24}$	N/A	.06	1.1	.8681	+0.0009/-0				
	MCFE 40A SBX			-	$\frac{8}{31}$								
MCFR 40A	MCFR 40A S			$\frac{6}{24}$	N/A					M18x1.5	118 1,044	5,000	.25 .55
MCFR 40A B	MCFR 40A SB	10	3	-	$\frac{8}{31}$	1.5	27	18.000	+0.018/-0				
MCFR 40A X	MCFR 40A SX	.394	.118	$\frac{6}{24}$	N/A	.06	1.1	.7087	+0.0007/-0				
MCFR 40A BX	MCFR 40A SBX			-	$\frac{8}{31}$								
MCFRE 40A	MCFRE 40A S			$\frac{6}{24}$	N/A					M18x1.5	118 1,044	5,000	.25 .55
	MCFRE 40A SB	N/A	N/A	-	$\frac{8}{31}$	1.5	27	22.050	+0.025/-0				
	MCFRE 40A SX			$\frac{6}{24}$	N/A	.06	1.1	.8681	+0.0009/-0				
	MCFRE 40A SBX			-	$\frac{8}{31}$								
MCF 47	MCF 47 S			$\frac{8}{31}$	N/A					M20x1.5	118 1,044	2,600	.39 .86
MCF 47 B	MCF 47 SB	9	4	-	$\frac{10}{39}$	1.5	30	20.000	+0.021/-0				
MCF 47 X	MCF 47 SX	.354	.157	$\frac{8}{31}$	N/A	.06	1.2	.7874	+0.0008/-0				
MCF 47 BX	MCF 47 SBX			-	$\frac{10}{39}$								
MCFE 47	MCFE 47 S			$\frac{8}{31}$	N/A					M20x1.5	118 1,044	2,600	.39 .86
	MCFE 47 SB	N/A	N/A	-	$\frac{10}{39}$	1.5	30	24.050	+0.025/-0				
	MCFE 47 SX			$\frac{8}{31}$	N/A	.06	1.2	.9469	+0.0009/-0				
	MCFE 47 SBX			-	$\frac{10}{39}$								
MCFR 47	MCFR 47 S			$\frac{8}{31}$	N/A					M20x1.5	118 1,044	3,900	.39 .86
MCFR 47 B	MCFR 47 SB	9	4	-	$\frac{10}{39}$	1.5	30	20.000	+0.021/-0				
MCFR 47 X	MCFR 47 SX	.354	.157	$\frac{8}{31}$	N/A	.06	1.2	.7874	+0.0008/-0				
MCFR 47 BX	MCFR 47 SBX			-	$\frac{10}{39}$								
MCFRE 47	MCFRE 47 S			$\frac{8}{31}$	N/A					M20x1.5	118 1,044	3,900	.39 .86
	MCFRE 47 SB	N/A	N/A	-	$\frac{10}{39}$	1.5	30	24.050	+0.025/-0				
	MCFRE 47 SX			$\frac{8}{31}$	N/A	.06	1.2	.9469	+0.0009/-0				
	MCFRE 47 SBX			-	$\frac{10}{39}$								



# McGILL® Metric CAMROL Bearings



- Basic Construction Type:** Stud Type Crowned / Cylindrical Outside Diameter
- Rolling Elements:** Full Complement / Retained (Caged) Needle Roller
- Bearing Material:** Bearing Quality Steel
- Seal Type:** LUBRI-DISC®
- Lubrication:** Lithium Soap Grease NLGI #2
- System Configuration:** Concentric / Eccentric
- Mounting Feature:** Slot / Hex Hole

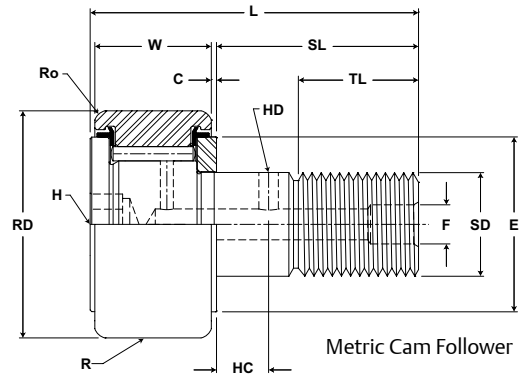

## MCF, MCFE

Part No.		RD		W		SD		SL	C	TL	L	R	ECC	G	BD	Track Roller Dynamic Rating	Track Roller Static Rating	
W/O Seals	With LUBRI-DISC Seals	Roller Diameter		Roller Width		Stud Diameter		Stud Length	Endplate Extension	Minimum Thread Length	Length Overall	Cylindrical	Eccentric					
		mm inch		mm inch		mm inch		mm inch	mm inch	mm inch	mm inch	mm inch	Base Modifier MCFE-xx					
		Nom.	Tol.	Nom.	Tol.	Nom.	Tol.	(Ref)	(Ref)	(Ref)	(Ref)	Radius	(Ref)	+05/- .15 + .002/- .006	(Ref)			
MCF 47A	MCF 47A S	47.000 1.8504	+0/- .050 +0/- .002	24.000 +0/- .12 .9449 +0/- .005	20.000 +0/- .021 .7874 +0/- .0008	41	.80	.031	22.0	.87	66	2.6	500	N/A	N/A	N/A	25,690	46,700
MCF 47A B	MCF 47A SB		19.7															
MCF 47A X	MCF 47A SX		Cylindrical															
MCF 47A BX	MCF 47A SBX		Cylindrical															
MCFE 47A	MCFE 47A S	47.000 1.8504	+0/- .050 +0/- .002	24.000 +0/- .12 .9449 +0/- .005	20.000 +0/- .021 .7874 +0/- .0008	41	.80	.031	22.0	.87	66	2.6	500	1	18	24	5,776	10,499
MCFE 47A B	MCFE 47A SB		19.7															
MCFE 47A X	MCFE 47A SX		Cylindrical															
MCFE 47A BX	MCFE 47A SBX		Cylindrical															
MCFR 47A	MCFR 47A S	47.000 1.8504	+0/- .050 +0/- .002	24.000 +0/- .12 .9449 +0/- .005	20.000 +0/- .021 .7874 +0/- .0008	41	.80	.031	22.0	.87	66	2.6	500	N/A	N/A	N/A	17,750	29,800
MCFR 47A B	MCFR 47A SB		19.7															
MCFR 47A X	MCFR 47A SX		Cylindrical															
MCFR 47A BX	MCFR 47A SBX		Cylindrical															
MCFRE 47A	MCFRE 47A S	47.000 1.8504	+0/- .050 +0/- .002	24.000 +0/- .12 .9449 +0/- .005	20.000 +0/- .021 .7874 +0/- .0008	41	.80	.031	22.0	.87	66	2.6	500	1	18	24	3,991	6,700
MCFRE 47A B	MCFRE 47A SB		19.7															
MCFRE 47A X	MCFRE 47A SX		Cylindrical															
MCFRE 47A BX	MCFRE 47A SBX		Cylindrical															
MCF 52	MCF 52 S	52.000 2.0472	+0/- .050 +0/- .002	24.000 +0/- .12 .9449 +0/- .005	20.000 +0/- .021 .7874 +0/- .0008	41	.80	.031	21.0	.83	66	2.6	500	N/A	N/A	N/A	25,690	46,700
MCF 52 B	MCF 52 SB		19.7															
MCF 52 X	MCF 52 SX		Cylindrical															
MCF 52 BX	MCF 52 SBX		Cylindrical															
MCFE 52	MCFE 52 S	52.000 2.0472	+0/- .050 +0/- .002	24.000 +0/- .12 .9449 +0/- .005	20.000 +0/- .021 .7874 +0/- .0008	41	.80	.031	21.0	.83	66	2.6	500	1	18	24	5,776	10,499
MCFE 52 B	MCFE 52 SB		19.7															
MCFE 52 X	MCFE 52 SX		Cylindrical															
MCFE 52 BX	MCFE 52 SBX		Cylindrical															
MCFR 52	MCFR 52 S	52.000 2.0472	+0/- .050 +0/- .002	24.000 +0/- .12 .9449 +0/- .005	20.000 +0/- .021 .7874 +0/- .0008	41	.80	.031	21.0	.83	66	2.6	500	N/A	N/A	N/A	17,750	29,800
MCFR 52 B	MCFR 52 SB		19.7															
MCFR 52 X	MCFR 52 SX		Cylindrical															
MCFR 52 BX	MCFR 52 SBX		Cylindrical															
MCFRE 52	MCFRE 52 S	52.000 2.0472	+0/- .050 +0/- .002	24.000 +0/- .12 .9449 +0/- .005	20.000 +0/- .021 .7874 +0/- .0008	41	.80	.031	21.0	.83	66	2.6	500	1	18	24	3,991	6,700
MCFRE 52 B	MCFRE 52 SB		19.7															
MCFRE 52 X	MCFRE 52 SX		Cylindrical															
MCFRE 52 BX	MCFRE 52 SBX		Cylindrical															

1. Standard bearing has a crowned roller outside diameter. For straight cylindrical outside roller diameter, add suffix "X". Example - MCFR-35-X or MCF-35-SX.  
 2. Clamping torque is based on dry threads. If threads are lubricated, use half of value shown.  
 3. Static load rating is based on stud strength or on internal rolling element load distribution stresses.  
 4. Dynamic load should not exceed 50% of Dynamic Rating as a track roller.  
 5. Since load, lubrication method, temperature and other factors affect the maximum operating speed, it is impossible to determine precise limiting speed. The listed limiting speeds are based on lightly loaded bearings having adequate lubrication and are listed only as a design guide. More frequent relubrication is required when operating at higher speeds. Actual bearing testing in the specific application should be conducted if the anticipated operating speed approaches the listed limiting speed.

Inch dimensions for reference only.  
 Not all parts are available from stock. Please contact customer service for availability (800) 626-2120.  
 For more information on bearing capabilities outside of our standard offering, please contact Application Engineering (800) 626-2093.

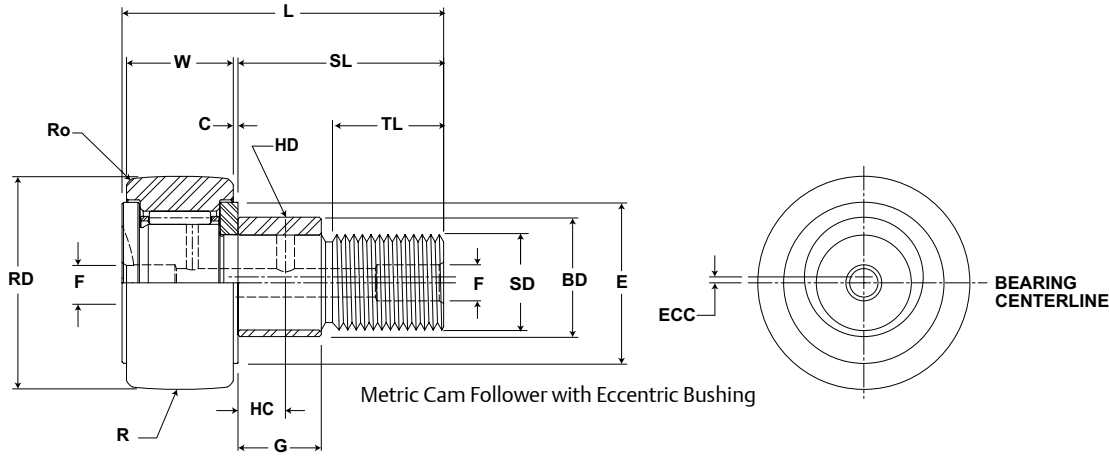

## MCF, MCFE

Part No.		HC	HD	F	H	Ro	E	Housing Bore Diameter		Thread Type	Clamping Torque	Limiting Speed (Grease)	WT			
W/O Seals	With LUBRI-DISC Seals	Hole Center	Radial Lub. Hole Diameter	Lub. Hole Dia	Hex Hole Suffix MCF_xx B	Outer Corner	Min. Clamping Diameter							Nm in-lb	RPM	kg lb
		mm inch		mm inch		mm inch		mm inch								
		(Ref)	(Ref)	(Ref)	(Ref)	(Ref)	(Ref)	Nom.	Tol.							
MCF 47A	MCF 47A S			$\frac{8}{.31}$	N/A					M20x1.5	118 1,044	2,600	.39 .86			
MCF 47A B	MCF 47A SB	12	4	-	$\frac{10}{.39}$	1.5	30	20.000	+0.021/-0							
MCF 47A X	MCF 47A SX	.472	.157	$\frac{8}{.31}$	N/A	.06	1.2	.7874	+0.0008/-0							
MCF 47A BX	MCF 47A SBX			-	$\frac{10}{.39}$											
MCFE 47A	MCFE 47A S			$\frac{8}{.31}$	N/A					M20x1.5	118 1,044	2,600	.39 .86			
	MCFE 47A SB	N/A	N/A	-	$\frac{10}{.39}$	1.5	30	24.050	+0.025/-0							
	MCFE 47A SX			$\frac{8}{.31}$	N/A	.06	1.2	.9469	+0.0009/-0							
	MCFE 47A SBX			-	$\frac{10}{.39}$											
MCFR 47A	MCFR 47A S			$\frac{8}{.31}$	N/A					M20x1.5	118 1,044	3,900	.39 .86			
MCFR 47A B	MCFR 47A SB	12	4	-	$\frac{10}{.39}$	1.5	30	20.000	+0.021/-0							
MCFR 47A X	MCFR 47A SX	.472	.157	$\frac{8}{.31}$	N/A	.06	1.2	.7874	+0.0008/-0							
MCFR 47A BX	MCFR 47A SBX			-	$\frac{10}{.39}$											
MCFRE 47A	MCFRE 47A S			$\frac{8}{.31}$	N/A					M20x1.5	118 1,044	3,900	.39 .86			
	MCFRE 47A SB	N/A	N/A	-	$\frac{10}{.39}$	1.5	30	24.050	+0.025/-0							
	MCFRE 47A SX			$\frac{8}{.31}$	N/A	.06	1.2	.9469	+0.0009/-0							
	MCFRE 47A SBX			-	$\frac{10}{.39}$											
MCF 52	MCF 52 S			$\frac{8}{.31}$	N/A					M20x1.5	118 1,044	2,600	.45 .99			
MCF 52 B	MCF 52 SB	9	4	-	$\frac{10}{.39}$	1.5	36	20.000	+0.021/-0							
MCF 52 X	MCF 52 SX	.354	.157	$\frac{8}{.31}$	N/A	.06	1.4	.7874	+0.0008/-0							
MCF 52 BX	MCF 52 SBX			-	$\frac{10}{.39}$											
MCFE 52	MCFE 52 S			$\frac{8}{.31}$	N/A					M20x1.5	118 1,044	2,600	.45 .99			
	MCFE 52 SB	N/A	N/A	-	$\frac{10}{.39}$	1.5	36	24.050	+0.025/-0							
	MCFE 52 SX			$\frac{8}{.31}$	N/A	.06	1.4	.9469	+0.0009/-0							
	MCFE 52 SBX			-	$\frac{10}{.39}$											
MCFR 52	MCFR 52 S			$\frac{8}{.31}$	N/A					M20x1.5	118 1,044	3,900	.45 .99			
MCFR 52 B	MCFR 52 SB	9	4	-	$\frac{10}{.39}$	1.5	36	20.000	+0.021/-0							
MCFR 52 X	MCFR 52 SX	.354	.157	$\frac{8}{.31}$	N/A	.06	1.4	.7874	+0.0008/-0							
MCFR 52 BX	MCFR 52 SBX			-	$\frac{10}{.39}$											
MCFRE 52	MCFRE 52 S			$\frac{8}{.31}$	N/A					M20x1.5	118 1,044	3,900	.45 .99			
	MCFRE 52 SB	N/A	N/A	-	$\frac{10}{.39}$	1.5	36	24.050	+0.025/-0							
	MCFRE 52 SX			$\frac{8}{.31}$	N/A	.06	1.4	.9469	+0.0009/-0							
	MCFRE 52 SBX			-	$\frac{10}{.39}$											

# MCGILL® Metric CAMROL Bearings



- Basic Construction Type:** Stud Type Crowned / Cylindrical Outside Diameter
- Rolling Elements:** Full Complement / Retained (Caged) Needle Roller
- Bearing Material:** Bearing Quality Steel
- Seal Type:** LUBRI-DISC®
- Lubrication:** Lithium Soap Grease NLGI #2
- System Configuration:** Concentric / Eccentric
- Mounting Feature:** Slot / Hex Hole

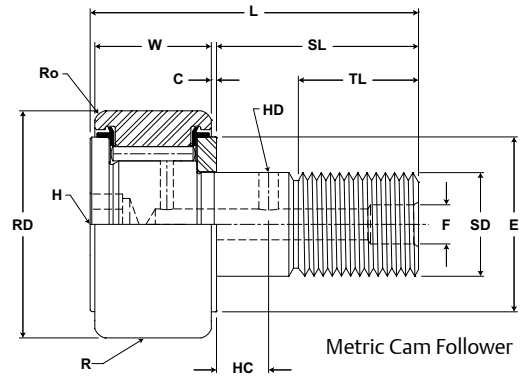

## MCF, MCFE

Part No.		RD		W		SD		SL	C	TL	L	R	ECC	G	BD	Track Roller Dynamic Rating	Track Roller Static Rating	
W/O Seals	With LUBRI-DISC Seals	Roller Diameter		Roller Width		Stud Diameter		Stud Length	Endplate Extension	Minimum Thread Length	Length Overall	Cylindrical	Eccentric					
		mm inch		mm inch		mm inch		mm inch		mm inch		mm inch	Base Modifier					
		Nom.	Tol.	Nom.	Tol.	Nom.	Tol.	(Ref)	(Ref)	(Ref)	(Ref)	Radius	(Ref)	+05/- .15 + .002/- .006	(Ref)			
MCF 52A	MCF 52A S	52.000 2.0472	+0/- .050 +0/- .002	24.000 +0/- .12 .9449 +0/- .005	20.000 +0/- .021 .7874 +0/- .0008	41	.80	22.0	66	500 19.7	66	500 19.7	N/A	N/A	N/A	25,690 5,776	46,700 10,499	
MCF 52A B	MCF 52A SB		+0/- .013 +0/- .0005															Cylindrical
MCF 52A X	MCF 52A SX																	
MCF 52A BX	MCF 52A SBX																	
MCFE 52A	MCFE 52A S	52.000 2.0472	+0/- .050 +0/- .002	24.000 +0/- .12 .9449 +0/- .005	20.000 +0/- .021 .7874 +0/- .0008	41	.80	22.0	66	500 19.7	66	500 19.7	1	18	24	25,690 5,776	46,700 10,499	
MCFE 52A B	MCFE 52A SB		+0/- .013 +0/- .0005															Cylindrical
MCFE 52A X	MCFE 52A SX																	
MCFE 52A BX	MCFE 52A SBX																	
MCFR 52A	MCFR 52A S	52.000 2.0472	+0/- .050 +0/- .002	24.000 +0/- .12 .9449 +0/- .005	20.000 +0/- .021 .7874 +0/- .0008	41	.80	22.0	66	500 19.7	66	500 19.7	N/A	N/A	N/A	17,750 3,991	29,800 6,700	
MCFR 52A B	MCFR 52A SB		+0/- .013 +0/- .0005															Cylindrical
MCFR 52A X	MCFR 52A SX																	
MCFR 52A BX	MCFR 52A SBX																	
MCFRE 52A	MCFRE 52A S	52.000 2.0472	+0/- .050 +0/- .002	24.000 +0/- .12 .9449 +0/- .005	20.000 +0/- .021 .7874 +0/- .0008	41	.80	22.0	66	500 19.7	66	500 19.7	1	18	24	17,750 3,991	29,800 6,700	
MCFRE 52A B	MCFRE 52A SB		+0/- .013 +0/- .0005															Cylindrical
MCFRE 52A X	MCFRE 52A SX																	
MCFRE 52A BX	MCFRE 52A SBX																	
MCF 62	MCF 62 S	62.000 2.4409	+0/- .050 +0/- .002	29.000 +0/- .12 1.1417 +0/- .005	24.000 +0/- .021 .9449 +0/- .0008	50	.80	25.0	80	500 19.7	80	500 19.7	N/A	N/A	N/A	38,840 8,732	65,400 14,703	
MCF 62 B	MCF 62 SB		+0/- .013 +0/- .0005															Cylindrical
MCF 62 X	MCF 62 SX																	
MCF 62 BX	MCF 62 SBX																	
MCFE 62	MCFE 62 S	62.000 2.4409	+0/- .050 +0/- .002	29.000 +0/- .12 1.1417 +0/- .005	24.000 +0/- .021 .9449 +0/- .0008	50	.80	25.0	80	500 19.7	80	500 19.7	1	22	28	38,840 8,732	65,400 14,703	
MCFE 62 B	MCFE 62 SB		+0/- .013 +0/- .0005															Cylindrical
MCFE 62 X	MCFE 62 SX																	
MCFE 62 BX	MCFE 62 SBX																	
MCFR 62	MCFR 62 S	62.000 2.4409	+0/- .050 +0/- .002	29.000 +0/- .12 1.1417 +0/- .005	24.000 +0/- .021 .9449 +0/- .0008	50	.80	25.0	80	500 19.7	80	500 19.7	N/A	N/A	N/A	26,380 5,931	46,300 10,409	
MCFR 62 B	MCFR 62 SB		+0/- .013 +0/- .0005															Cylindrical
MCFR 62 X	MCFR 62 SX																	
MCFR 62 BX	MCFR 62 SBX																	
MCFRE 62	MCFRE 62 S	62.000 2.4409	+0/- .050 +0/- .002	29.000 +0/- .12 1.1417 +0/- .005	24.000 +0/- .021 .9449 +0/- .0008	50	.80	25.0	80	500 19.7	80	500 19.7	1	22	28	26,380 5,931	46,300 10,409	
MCFRE 62 B	MCFRE 62 SB		+0/- .013 +0/- .0005															Cylindrical
MCFRE 62 X	MCFRE 62 SX																	
MCFRE 62 BX	MCFRE 62 SBX																	

1. Standard bearing has a crowned roller outside diameter. For straight cylindrical outside roller diameter, add suffix "X". Example - MCFR-35-X or MCF-35-SX.  
 2. Clamping torque is based on dry threads. If threads are lubricated, use half of value shown.  
 3. Static load rating is based on stud strength or on internal rolling element load distribution stresses.  
 4. Dynamic load should not exceed 50% of Dynamic Rating as a track roller.  
 5. Since load, lubrication method, temperature and other factors affect the maximum operating speed, it is impossible to determine precise limiting speed. The listed limiting speeds are based on lightly loaded bearings having adequate lubrication and are listed only as a design guide. More frequent relubrication is required when operating at higher speeds. Actual bearing testing in the specific application should be conducted if the anticipated operating speed approaches the listed limiting speed.

Inch dimensions for reference only.  
 Not all parts are available from stock. Please contact customer service for availability (800) 626-2120.  
 For more information on bearing capabilities outside of our standard offering, please contact Application Engineering (800) 626-2093.

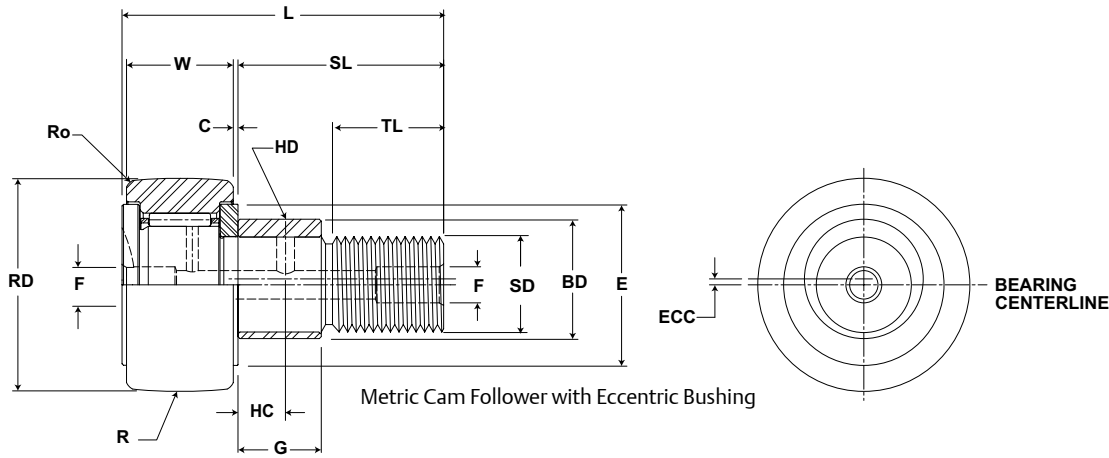

## MCF, MCFE

Part No.		HC	HD	F	H	Ro	E	Housing Bore Diameter		Thread Type	Clamping Torque	Limiting Speed (Grease)	WT
W/O Seals	With LUBRI-DISC Seals	Hole Center	Radial Lub. Hole Diameter	Lub. Hole Dia	Hex Hole Suffix MCF_xx B	Outer Corner	Min. Clamping Diameter						
		mm inch	mm inch	mm inch	mm inch	mm inch	mm inch						
		(Ref)	(Ref)	(Ref)	(Ref)	(Ref)	Nom.	Tol.	Nm in-lb	RPM	kg lb		
MCF 52A	MCF 52A S			$\frac{8}{.31}$	N/A					M20x1.5	216 1,912	2,600	.45 .99
MCF 52A B	MCF 52A SB	12	4	-	$\frac{10}{.39}$	1.5	36	20.000	+0.021/-0				
MCF 52A X	MCF 52A SX	.472	.157	$\frac{8}{.31}$	N/A	.06	1.4	.7874	+0.0008/-0				
MCF 52A BX	MCF 52A SBX			-	$\frac{10}{.39}$								
MCFE 52A	MCFE 52A S			$\frac{8}{.31}$	N/A					M20x1.5	216 1,912	2,600	.45 .99
	MCFE 52A SB	N/A	N/A	-	$\frac{10}{.39}$	1.5	36	24.050	+0.025/-0				
	MCFE 52A SX			$\frac{8}{.31}$	N/A	.06	1.4	.9469	+0.0009/-0				
	MCFE 52A SBX			-	$\frac{10}{.39}$								
MCFR 52A	MCFR 52A S			$\frac{8}{.31}$	N/A					M20x1.5	216 1,912	3,900	.45 .99
MCFR 52A B	MCFR 52A SB	12	4	-	$\frac{10}{.39}$	1.5	36	20.000	+0.021/-0				
MCFR 52A X	MCFR 52A SX	.472	.157	$\frac{8}{.31}$	N/A	.06	1.4	.7874	+0.0008/-0				
MCFR 52A BX	MCFR 52A SBX			-	$\frac{10}{.39}$								
MCFRE 52A	MCFRE 52A S			$\frac{8}{.31}$	N/A					M20x1.5	216 1,912	3,900	.45 .99
	MCFRE 52A SB	N/A	N/A	-	$\frac{10}{.39}$	1.5	36	24.050	+0.025/-0				
	MCFRE 52A SX			$\frac{8}{.31}$	N/A	.06	1.4	.9469	+0.0009/-0				
	MCFRE 52A SBX			-	$\frac{10}{.39}$								
MCF 62	MCF 62 S			$\frac{8}{.31}$	N/A					M24x1.5	216 1,912	2,100	.81 1.79
MCF 62 B	MCF 62 SB	11	4	-	$\frac{14}{.55}$	2.0	44	24.000	+0.021/-0				
MCF 62 X	MCF 62 SX	.433	.157	$\frac{8}{.31}$	N/A	.08	1.7	.9449	+0.0008/-0				
MCF 62 BX	MCF 62 SBX			-	$\frac{14}{.55}$								
MCFE 62	MCFE 62 S			$\frac{8}{.31}$	N/A					M24x1.5	216 1,912	2,100	.81 1.79
	MCFE 62 SB	N/A	N/A	-	$\frac{14}{.55}$	2.0	63	28.050	+0.025/-0				
	MCFE 62 SX			$\frac{8}{.31}$	N/A	.08	2.5	.1043	+0.0009/-0				
	MCFE 62 SBX			-	$\frac{14}{.55}$								
MCFR 62	MCFR 62 S			$\frac{8}{.31}$	N/A					M24x1.5	216 1,912	3,100	.81 1.79
MCFR 62 B	MCFR 62 SB	11	4	-	$\frac{14}{.55}$	2.0	63	24.000	+0.021/-0				
MCFR 62 X	MCFR 62 SX	.433	.157	$\frac{8}{.31}$	N/A	.08	2.5	.9449	+0.0008/-0				
MCFR 62 BX	MCFR 62 SBX			-	$\frac{14}{.55}$								
MCFRE 62	MCFRE 62 S			$\frac{8}{.31}$	N/A					M24x1.5	216 1,912	3,100	.81 1.79
	MCFRE 62 SB	N/A	N/A	-	$\frac{14}{.55}$	2.0	63	28.050	+0.025/-0				
	MCFRE 62 SX			$\frac{8}{.31}$	N/A	.08	2.5	.1043	+0.0009/-0				
	MCFRE 62 SBX			-	$\frac{14}{.55}$								

# McGILL® Metric CAMROL Bearings



- Basic Construction Type:** Stud Type Crowned / Cylindrical Outside Diameter
- Rolling Elements:** Full Complement / Retained (Caged) Needle Roller
- Bearing Material:** Bearing Quality Steel
- Seal Type:** LUBRI-DISC®
- Lubrication:** Lithium Soap Grease NLGI #2
- System Configuration:** Concentric / Eccentric
- Mounting Feature:** Slot / Hex Hole

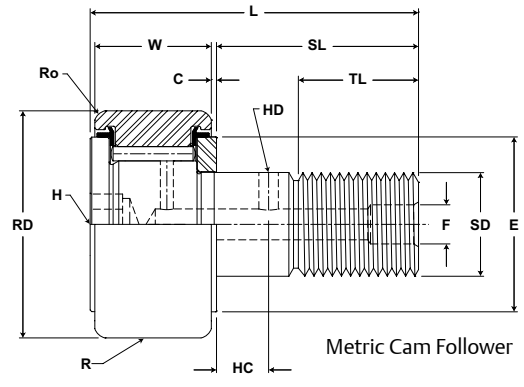

## MCF, MCFE

Part No.		RD		W		SD		SL	C	TL	L	R	ECC	G	BD	Track Roller Dynamic Rating	Track Roller Static Rating	
W/O Seals	With LUBRI-DISC Seals	Roller Diameter		Roller Width		Stud Diameter		Stud Length	Endplate Extension	Minimum Thread Length	Length Overall	Cylindrical	Eccentric					
		mm inch		mm inch		mm inch		mm inch	mm inch	mm inch	mm inch	Suffix MCF-xx-X	Base Modifier MCFE-xx					
		Nom.	Tol.	Nom.	Tol.	Nom.	Tol.	(Ref)	(Ref)	(Ref)	(Ref)	Radius	(Ref)	+05/- .15 + .002/- .006	(Ref)	N/lb	N/lb	
MCF 62A	MCF 62A S	62.000 2.4409	+0/- .050 +0/- .002	29.000 +0/- .12 1.1417 +0/- .005	24.000 +0/- .021 .9449 +0/- .0008	50 1.9	.80 .031	25.0 .98	80 3.1	500 19.7	N/A	N/A	N/A	N/A	N/A	38,840 8,732	65,400 14,703	
MCF 62A B	MCF 62A SB		Cylindrical															
MCF 62A X	MCF 62A SX																	
MCF 62A BX	MCF 62A SBX																	
MCFE 62A	MCFE 62A S	62.000 2.4409	+0/- .050 +0/- .002	29.000 +0/- .12 1.1417 +0/- .005	24.000 +0/- .021 .9449 +0/- .0008	50 1.9	.80 .031	25.0 .98	80 3.1	500 19.7	1 .04	22 0.87	28 .10	N/A	N/A	N/A	26,380 5,931	46,300 10,409
MCFE 62A B	MCFE 62A SB		Cylindrical															
MCFE 62A X	MCFE 62A SX																	
MCFE 62A BX	MCFE 62A SBX																	
MCFRE 62A	MCFRE 62A S	62.000 2.4409	+0/- .050 +0/- .002	29.000 +0/- .12 1.1417 +0/- .005	24.000 +0/- .021 .9449 +0/- .0008	50 1.9	.80 .031	25.0 .98	80 3.1	500 19.7	1 .04	22 0.87	28 .10	N/A	N/A	N/A	26,380 5,931	46,300 10,409
MCFRE 62A B	MCFRE 62A SB		Cylindrical															
MCFRE 62A X	MCFRE 62A SX																	
MCFRE 62A BX	MCFRE 62A SBX																	
MCF 72	MCF 72 S	72.000 2.8346	+0/- .050 +0/- .002	29.000 +0/- .12 1.1417 +0/- .005	24.000 +0/- .021 .9449 +0/- .0008	50 1.9	.80 .031	25.0 .98	80 3.1	500 19.7	N/A	N/A	N/A	N/A	N/A	38,840 8,732	65,400 14,703	
MCF 72 B	MCF 72 SB		Cylindrical															
MCF 72 X	MCF 72 SX																	
MCF 72 BX	MCF 72 SBX																	
MCFE 72	MCFE 72 S	72.000 2.8346	+0/- .050 +0/- .002	29.000 +0/- .12 1.1417 +0/- .005	24.000 +0/- .021 .9449 +0/- .0008	50 1.9	.80 .031	25.0 .98	80 3.1	500 19.7	1 .04	22 0.87	28 .10	N/A	N/A	N/A	26,380 5,931	46,300 10,409
MCFE 72 B	MCFE 72 SB		Cylindrical															
MCFE 72 X	MCFE 72 SX																	
MCFE 72 BX	MCFE 72 SBX																	
MCFRE 72	MCFRE 72 S	72.000 2.8346	+0/- .050 +0/- .002	29.000 +0/- .12 1.1417 +0/- .005	24.000 +0/- .021 .9449 +0/- .0008	50 1.9	.80 .031	25.0 .98	80 3.1	500 19.7	1 .04	22 0.87	28 .10	N/A	N/A	N/A	26,380 5,931	46,300 10,409
MCFRE 72 B	MCFRE 72 SB		Cylindrical															
MCFRE 72 X	MCFRE 72 SX																	
MCFRE 72 BX	MCFRE 72 SBX																	

1. Standard bearing has a crowned roller outside diameter. For straight cylindrical outside roller diameter, add suffix "X". Example - MCFR-35-X or MCF-35-SX.  
 2. Clamping torque is based on dry threads. If threads are lubricated, use half of value shown.  
 3. Static load rating is based on stud strength or on internal rolling element load distribution stresses.  
 4. Dynamic load should not exceed 50% of Dynamic Rating as a track roller.  
 5. Since load, lubrication method, temperature and other factors affect the maximum operating speed, it is impossible to determine precise limiting speed. The listed limiting speeds are based on lightly loaded bearings having adequate lubrication and are listed only as a design guide. More frequent relubrication is required when operating at higher speeds. Actual bearing testing in the specific application should be conducted if the anticipated operating speed approaches the listed limiting speed.

Inch dimensions for reference only.  
 Not all parts are available from stock. Please contact customer service for availability (800) 626-2120.  
 For more information on bearing capabilities outside of our standard offering, please contact Application Engineering (800) 626-2093.

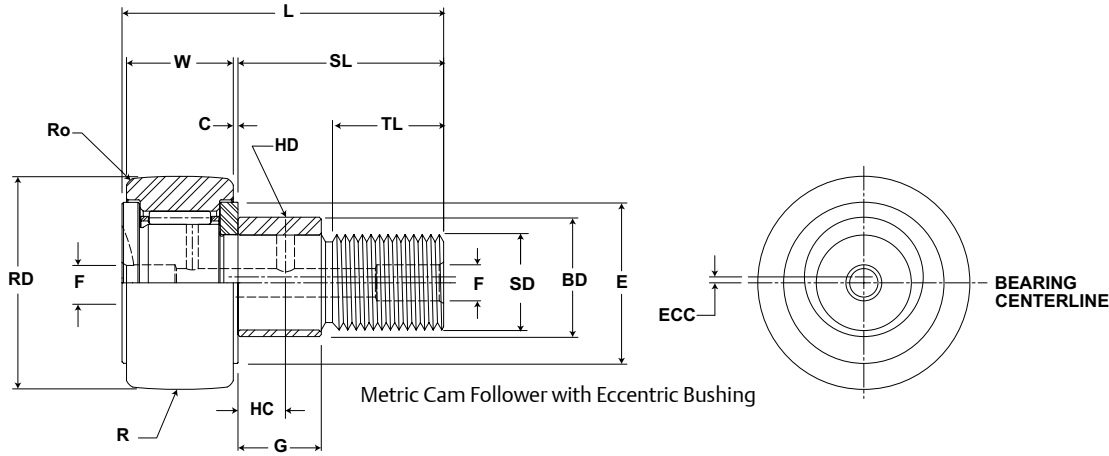

## MCF, MCFE

Part No.		HC	HD	F	H	Ro	E	Housing Bore Diameter		Thread Type	Clamping Torque	Limiting Speed (Grease)	WT
W/O Seals	With LUBRI-DISC Seals	Hole Center	Radial Lub. Hole Diameter	Lub. Hole Dia	Hex Hole Suffix MCF_xx B	Outer Corner	Min. Clamping Diameter						
		mm inch		mm inch		mm inch		mm inch					
		(Ref)	(Ref)	(Ref)	(Ref)	(Ref)	(Ref)	Nom.	Tol.	Nm in-lb	RPM	kg lb	
MCF 62A	MCF 62A S	12 .472	4 .157	8 .31	N/A	2.0 .08	63 2.5	24.000 .9449	+0.021/-0 +0.0008/-0	M24x1.5	216 1,912	2,100	.81 1.79
MCF 62A B	MCF 62A SB			-	14 .55								
MCF 62A X	MCF 62A SX			8 .31	N/A								
MCF 62A BX	MCF 62A SBX			-	14 .55								
MCFE 62A	MCFE 62A S	N/A	N/A	8 .31	N/A	2.0 .08	63 2.5	28.050 .1043	+0.025/-0 +0.0009/-0	M24x1.5	216 1,912	2,100	.81 1.79
	MCFE 62A SB			-	14 .55								
	MCFE 62A SX			8 .31	N/A								
	MCFE 62A SBX			-	14 .55								
MCFR 62A	MCFR 62A S	12 .472	4 .157	8 .31	N/A	2.0 .08	63 2.5	24.000 .9449	+0.021/-0 +0.0008/-0	M24x1.5	216 1,912	3,100	.81 1.79
MCFR 62A B	MCFR 62A SB			-	14 .55								
MCFR 62A X	MCFR 62A SX			8 .31	N/A								
MCFR 62A BX	MCFR 62A SBX			-	14 .55								
MCFRE 62A	MCFRE 62A S	N/A	N/A	8 .31	N/A	2.0 .08	63 2.5	28.050 .1043	+0.025/-0 +0.0009/-0	M24x1.5	216 1,912	3,100	.81 1.79
	MCFRE 62A SB			-	14 .55								
	MCFRE 62A SX			8 .31	N/A								
	MCFRE 62A SBX			-	14 .55								
MCF 72	MCF 72 S	12 .472	4 .157	8 .31	N/A	2.0 .08	63 2.5	24.000 .9449	+0.021/-0 +0.0008/-0	M24x1.5	216 1,912	2,100	1.04 2.29
MCF 72 B	MCF 72 SB			-	14 .55								
MCF 72 X	MCF 72 SX			8 .31	N/A								
MCF 72 BX	MCF 72 SBX			-	14 .55								
MCFE 72	MCFE 72 S	N/A	N/A	8 .31	N/A	2.0 .08	63 2.5	28.050 .1043	+0.025/-0 +0.0009/-0	M24x1.5	216 1,912	2,100	1.04 2.29
	MCFE 72 SB			-	14 .55								
	MCFE 72 SX			8 .31	N/A								
	MCFE 72 SBX			-	14 .55								
MCFR 72	MCFR 72 S	12 .472	4 .157	8 .31	N/A	2.0 .08	63 2.5	24.000 .9449	+0.021/-0 +0.0008/-0	M24x1.5	216 1,912	3,100	1.04 2.29
MCFR 72 B	MCFR 72 SB			-	14 .55								
MCFR 72 X	MCFR 72 SX			8 .31	N/A								
MCFR 72 BX	MCFR 72 SBX			-	14 .55								
MCFRE 72	MCFRE 72 S	N/A	N/A	8 .31	N/A	2.0 .08	63 2.5	28.050 .1043	+0.025/-0 +0.0009/-0	M24x1.5	216 1,912	3,100	1.04 2.29
	MCFRE 72 SB			-	14 .55								
	MCFRE 72 SX			8 .31	N/A								
	MCFRE 72 SBX			-	14 .55								

# MCGILL® Metric CAMROL Bearings



- Basic Construction Type:** Stud Type Crowned / Cylindrical Outside Diameter
- Rolling Elements:** Full Complement / Retained (Caged) Needle Roller
- Bearing Material:** Bearing Quality Steel
- Seal Type:** LUBRI-DISC®
- Lubrication:** Lithium Soap Grease NLGI #2
- System Configuration:** Concentric / Eccentric
- Mounting Feature:** Slot / Hex Hole

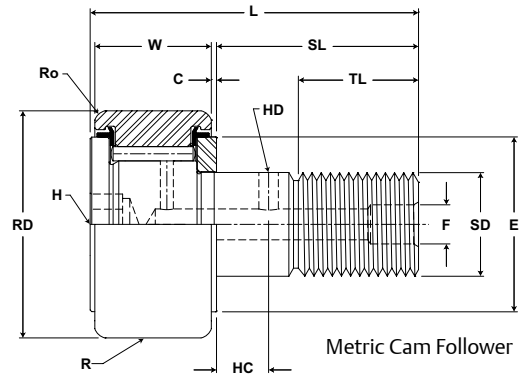

## MCF, MCFE

Part No.		RD		W		SD		SL	C	TL	L	R	ECC	G	BD	Track Roller Dynamic Rating	Track Roller Static Rating
W/O Seals	With LUBRI-DISC Seals	Roller Diameter		Roller Width		Stud Diameter		Stud Length	Endplate Extension	Minimum Thread Length	Length Overall	Cylindrical	Eccentric				
		mm inch		mm inch		mm inch		mm inch	mm inch	mm inch	mm inch	mm inch	Base Modifier MCFE-xx				
		Nom.	Tol.	Nom.	Tol.	Nom.	Tol.	(Ref)	(Ref)	(Ref)	(Ref)	Radius	(Ref)	+05/- .15 + .002/- .006	(Ref)		
MCF 72A	MCF 72A S	72.000 2.8346	+0/- .050 +0/- .002	29.000 +0/- .12 1.1417 +0/- .005	24.000 +0/- .021 .9449 +0/- .0008	50 1.9	.80 .031	25.0 .98	80 3.1	500 19.7	Cylindrical	N/A	N/A	N/A	38,840 8,732	65,400 14,703	
MCF 72A B	MCF 72A SB																
MCF 72A X	MCF 72A SX																
MCF 72A BX	MCF 72A SBX																
MCFE 72A	MCFE 72A S	72.000 2.8346	+0/- .050 +0/- .002	29.000 +0/- .12 1.1417 +0/- .005	24.000 +0/- .021 .9449 +0/- .0008	50 1.9	.80 .031	25.0 .98	80 3.1	500 19.7	Cylindrical	1 .04	22 0.87	28 .10	26,380 5,931	46,300 10,409	
MCFE 72A B	MCFE 72A SB																
MCFE 72A X	MCFE 72A SX																
MCFE 72A BX	MCFE 72A SBX																
MCFRE 72A	MCFRE 72A S	72.000 2.8346	+0/- .050 +0/- .002	29.000 +0/- .12 1.1417 +0/- .005	24.000 +0/- .021 .9449 +0/- .0008	50 1.9	.80 .031	25.0 .98	80 3.1	500 19.7	Cylindrical	1 .04	22 0.87	28 .10	64,140 14,420	102,300 22,999	
MCFRE 72A B	MCFRE 72A SB																
MCFRE 72A X	MCFRE 72A SX																
MCFRE 72A BX	MCFRE 72A SBX																
MCF 80	MCF 80 S	80.000 3.1496	+0/- .050 +0/- .002	35.000 +0/- .12 1.3780 +0/- .005	30.000 +0/- .021 1.1811 +0/- .0008	63 2.5	1.00 .039	32.0 1.26	100 3.9	500 19.7	Cylindrical	N/A	N/A	N/A	46,680 10,495	87,600 19,694	
MCF 80 B	MCF 80 SB																
MCF 80 X	MCF 80 SX																
MCF 80 BX	MCF 80 SBX																
MCFE 80	MCFE 80 S	80.000 3.1496	+0/- .050 +0/- .002	35.000 +0/- .12 1.3780 +0/- .005	30.000 +0/- .021 1.1811 +0/- .0008	63 2.5	1.00 .039	32.0 1.26	100 3.9	500 19.7	Cylindrical	1.5 .06	29 1.14	35 .38	MCFRE 80A	MCFRE 80A S	
MCFE 80 B	MCFE 80 SB																
MCFE 80 X	MCFE 80 SX																
MCFE 80 BX	MCFE 80 SBX																
MCFR 80A	MCFR 80A S	80.000 3.1496	+0/- .050 +0/- .002	35.000 +0/- .12 1.3780 +0/- .005	30.000 +0/- .021 1.1811 +0/- .0008	63 2.5	1.00 .039	32.0 1.26	100 3.9	500 19.7	Cylindrical	N/A	N/A	N/A	MCFRE 80A B	MCFRE 80A SB	
MCFR 80A B	MCFR 80A SB																
MCFR 80A X	MCFR 80A SX																
MCFR 80A BX	MCFR 80A SBX																
MCFRE 80A	MCFRE 80A S	80.000 3.1496	+0/- .050 +0/- .002	35.000 +0/- .12 1.3780 +0/- .005	30.000 +0/- .021 1.1811 +0/- .0008	63 2.5	1.00 .039	32.0 1.26	100 3.9	500 19.7	Cylindrical	1.5 .06	29 1.14	35 .38	MCFRE 80A X	MCFRE 80A SX	
MCFRE 80A B	MCFRE 80A SB																
MCFRE 80A X	MCFRE 80A SX																
MCFRE 80A BX	MCFRE 80A SBX																

1. Standard bearing has a crowned roller outside diameter. For straight cylindrical outside roller diameter, add suffix "X". Example - MCFR-35-X or MCF-35-SX.  
 2. Clamping torque is based on dry threads. If threads are lubricated, use half of value shown.  
 3. Static load rating is based on stud strength or on internal rolling element load distribution stresses.  
 4. Dynamic load should not exceed 50% of Dynamic Rating as a track roller.  
 5. Since load, lubrication method, temperature and other factors affect the maximum operating speed, it is impossible to determine precise limiting speed. The listed limiting speeds are based on lightly loaded bearings having adequate lubrication and are listed only as a design guide. More frequent relubrication is required when operating at higher speeds. Actual bearing testing in the specific application should be conducted if the anticipated operating speed approaches the listed limiting speed.

Inch dimensions for reference only.  
 Not all parts are available from stock. Please contact customer service for availability (800) 626-2120.  
 For more information on bearing capabilities outside of our standard offering, please contact Application Engineering (800) 626-2093.

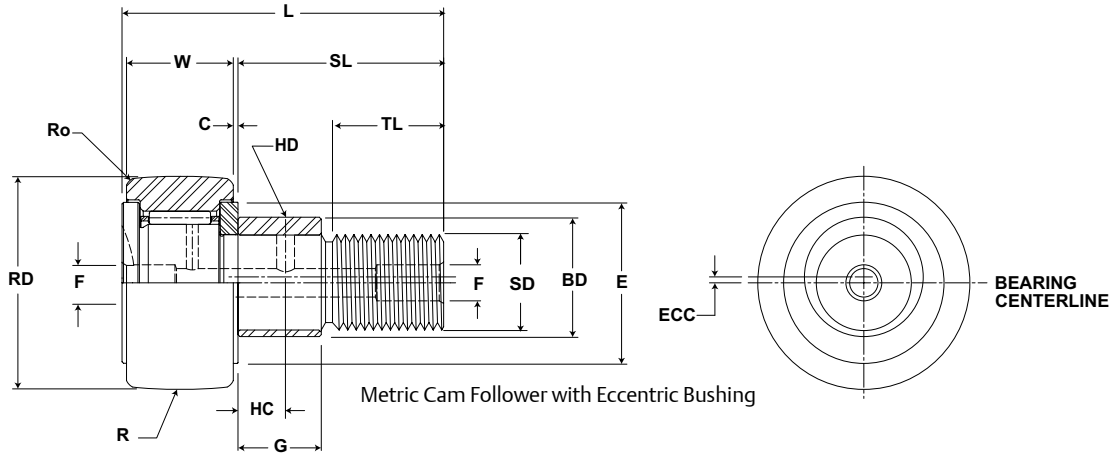

## MCF, MCFE

Part No.		HC	HD	F	H	Ro	E	Housing Bore Diameter		Thread Type	Clamping Torque	Limiting Speed (Grease)	WT
W/O Seals	With LUBRI-DISC Seals	Hole Center	Radial Lub. Hole Diameter	Lub. Hole Dia	Hex Hole Suffix MCF_xx B	Outer Corner	Min. Clamping Diameter						
		mm inch		mm inch		mm inch		mm inch					
		(Ref)	(Ref)	(Ref)	(Ref)	(Ref)	(Ref)	Nom.	Tol.	Nm in-lb	RPM	kg lb	
MCF 72A	MCF 72A S			$\frac{8}{.31}$	N/A					M24x1.5	216 1,912	2,100	1.04 2.29
MCF 72A B	MCF 72A SB	11	4	-	$\frac{14}{.55}$	2.0	63	24.000	+0.021/-0				
MCF 72A X	MCF 72A SX	.433	.157	$\frac{8}{.31}$	N/A	.08	2.5	.9449	+0.0008/-0				
MCF 72A BX	MCF 72A SBX			-	$\frac{14}{.55}$								
MCFE 72A	MCFE 72A S			$\frac{8}{.31}$	N/A					M24x1.5	216 1,912	2,100	1.04 2.29
	MCFE 72A SB	N/A	N/A	-	$\frac{14}{.55}$	2.0	63	28.050	+0.025/-0				
	MCFE 72A SX			$\frac{8}{.31}$	N/A	.08	2.5	.1043	+0.0009/-0				
	MCFE 72A SBX			-	$\frac{14}{.55}$								
MCFR 72A	MCFR 72A S			$\frac{8}{.31}$	N/A					M24x1.5	216 1,912	3,100	1.04 2.29
MCFR 72A B	MCFR 72A SB	11	4	-	$\frac{14}{.55}$	2.0	63	24.000	+0.021/-0				
MCFR 72A X	MCFR 72A SX	.433	.157	$\frac{8}{.31}$	N/A	.08	2.5	.9449	+0.0008/-0				
MCFR 72A BX	MCFR 72A SBX			-	$\frac{14}{.55}$								
MCFRE 72A	MCFRE 72A S			$\frac{8}{.31}$	N/A					M24x1.5	216 1,912	3,100	1.04 2.29
	MCFRE 72A SB	N/A	N/A	-	$\frac{14}{.55}$	2.0	63	28.050	+0.025/-0				
	MCFRE 72A SX			$\frac{8}{.31}$	N/A	.08	2.5	.1043	+0.0009/-0				
	MCFRE 72A SBX			-	$\frac{14}{.55}$								
MCF 80	MCF 80 S			$\frac{8}{.31}$	N/A					M30x1.5	441 3,903	1,500	1.64 3.62
MCF 80 B	MCF 80 SB	15	4	-	$\frac{14}{.55}$	2.0	63	30.000	+0.021/-0				
MCF 80 X	MCF 80 SX	.591	.157	$\frac{8}{.31}$	N/A	.08	2.5	.1811	+0.0008/-0				
MCF 80 BX	MCF 80 SBX			-	$\frac{14}{.55}$								
MCFE 80	MCFE 80 S			$\frac{8}{.31}$	N/A					M30x1.5	441 3,903	2,200	1.64 3.62
	MCFE 80 SB	N/A	N/A	-	$\frac{14}{.55}$	2.0	63	35.050	+0.025/-0				
	MCFE 80 SX			$\frac{8}{.31}$	N/A	.08	2.5	.3799	+0.0009/-0				
	MCFE 80 SBX			-	$\frac{14}{.55}$								
MCFR 80A	MCFR 80A S			$\frac{8}{.31}$	N/A					M30x1.5	441 3,903	2,200	1.64 3.62
MCFR 80A B	MCFR 80A SB	15	4	-	$\frac{14}{.55}$	2.0	63	30.000	+0.021/-0				
MCFR 80A X	MCFR 80A SX	.591	.157	$\frac{8}{.31}$	N/A	.08	2.5	.1811	+0.0008/-0				
MCFR 80A BX	MCFR 80A SBX			-	$\frac{14}{.55}$								
MCFRE 80A	MCFRE 80A S			$\frac{8}{.31}$	N/A					M30x1.5	441 3,903	2,200	1.64 3.62
	MCFRE 80A SB	N/A	N/A	-	$\frac{14}{.55}$	2.0	63	35.050	+0.025/-0				
	MCFRE 80A SX			$\frac{8}{.31}$	N/A	.08	2.5	.3799	+0.0009/-0				
	MCFRE 80A SBX			-	$\frac{14}{.55}$								



# MCGILL® Metric CAMROL Bearings



- Basic Construction Type:** Stud Type Crowned / Cylindrical Outside Diameter
- Rolling Elements:** Full Complement / Retained (Caged) Needle Roller
- Bearing Material:** Bearing Quality Steel
- Seal Type:** LUBRI-DISC®
- Lubrication:** Lithium Soap Grease NLGI #2
- System Configuration:** Concentric / Eccentric
- Mounting Feature:** Slot / Hex Hole

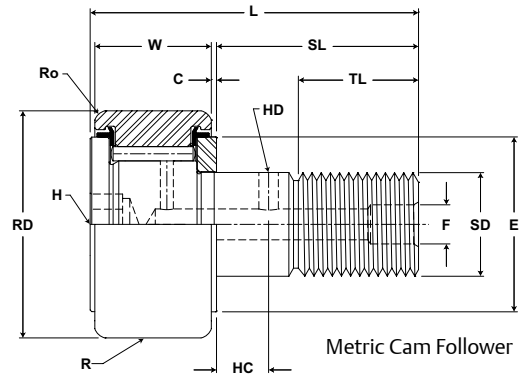

## MCF, MCFE

Part No.		RD		W		SD		SL	C	TL	L	R	ECC	G	BD	Track Roller Dynamic Rating	Track Roller Static Rating			
W/O Seals	With LUBRI-DISC Seals	Roller Diameter		Roller Width		Stud Diameter		Stud Length	Endplate Extension	Minimum Thread Length	Length Overall	Cylindrical	Eccentric							
		mm inch		mm inch		mm inch		mm inch	mm inch	mm inch	mm inch	mm inch	Base Modifier MCFE-xx							
		Nom.	Tol.	Nom.	Tol.	Nom.	Tol.	(Ref)	(Ref)	(Ref)	(Ref)	Radius	(Ref)	+05/- .15 + .002/- .006	(Ref)					
MCF 80	MCF 80 S	85.000 3.3465	+0/- .050 +0/- .002	35.000 +0/- .12 1.3780 +0/- .005	30.000 +0/- .021 1.1811 +0/- .0008	63	1.00	.039	32.0	1.26	100	3.9	500 19.7	N/A	N/A	N/A	64,140 14,420	102,300 22,999		
MCF 80 B	MCF 80 SB		+0/- .015 +0/- .0006																Cylindrical	
MCF 80 X	MCF 80 SX																			
MCF 80 BX	MCF 80 SBX																			
MCFE 80	MCFE 80 S	85.000 3.3465	+0/- .050 +0/- .002	35.000 +0/- .12 1.3780 +0/- .005	30.000 +0/- .021 1.1811 +0/- .0008	63	1.00	.039	32.0	1.26	100	3.9	500 19.7	1.5	.06	29	1.14	35	.38	
MCFE 80 SB	MCFE 80 SX		+0/- .015 +0/- .0006																	Cylindrical
MCFE 80 SBX	MCFE 80 SBX																			
MCFR 85	MCFR 85 S		85.000 3.3465																	+0/- .050 +0/- .002
MCFR 85 B	MCFR 85 SB	+0/- .015 +0/- .0006		Cylindrical																
MCFR 85 X	MCFR 85 SX																			
MCFR 85 BX	MCFR 85 SBX																			
MCFRE 85	MCFRE 85 S	85.000 3.3465	+0/- .050 +0/- .002	35.000 +0/- .12 1.3780 +0/- .005	30.000 +0/- .021 1.1811 +0/- .0008	63	1.00	.039	32.0	1.26	100	3.9	500 19.7	1.5	.06	29	1.14	35	.38	
MCFRE 85 B	MCFRE 85 SB		+0/- .015 +0/- .0006																	Cylindrical
MCFRE 85 X	MCFRE 85 SX																			
MCFRE 85 BX	MCFRE 85 SBX																			
MCF 90	MCF 90 S	90.000 3.5433	+0/- .050 +0/- .002	35.000 +0/- .12 1.3780 +0/- .005	30.000 +0/- .021 1.1811 +0/- .0008	63	1.00	.039	32.0	1.26	100	3.9	500 19.7	N/A	N/A	N/A	64,140 14,420	102,300 22,999		
MCF 90 B	MCF 90 SB		+0/- .015 +0/- .0006																Cylindrical	
MCF 90 X	MCF 90 SX																			
MCF 90 BX	MCF 90 SBX																			
MCFE 90	MCFE 90 S	90.000 3.5433	+0/- .050 +0/- .002	35.000 +0/- .12 1.3780 +0/- .005	30.000 +0/- .021 1.1811 +0/- .0008	63	1.00	.039	32.0	1.26	100	3.9	500 19.7	1.5	.06	29	1.14	35	.38	
MCFE 90 SB	MCFE 90 SX		+0/- .015 +0/- .0006																	Cylindrical
MCFE 90 SBX	MCFE 90 SBX																			
MCFR 90	MCFR 90 S		90.000 3.5433																	+0/- .050 +0/- .002
MCFR 90 B	MCFR 90 SB	+0/- .015 +0/- .0006		Cylindrical																
MCFR 90 X	MCFR 90 SX																			
MCFR 90 BX	MCFR 90 SBX																			
MCFRE 90	MCFRE 90 S	90.000 3.5433	+0/- .050 +0/- .002	35.000 +0/- .12 1.3780 +0/- .005	30.000 +0/- .021 1.1811 +0/- .0008	63	1.00	.039	32.0	1.26	100	3.9	500 19.7	1.5	.06	29	1.14	35	.38	
MCFRE 90 SB	MCFRE 90 SX		+0/- .015 +0/- .0006																	Cylindrical
MCFRE 90 SBX	MCFRE 90 SBX																			

1. Standard bearing has a crowned roller outside diameter. For straight cylindrical outside roller diameter, add suffix "X". Example - MCFR-35-X or MCF-35-SX.  
 2. Clamping torque is based on dry threads. If threads are lubricated, use half of value shown.  
 3. Static load rating is based on stud strength or on internal rolling element load distribution stresses.  
 4. Dynamic load should not exceed 50% of Dynamic Rating as a track roller.  
 5. Since load, lubrication method, temperature and other factors affect the maximum operating speed, it is impossible to determine precise limiting speed. The listed limiting speeds are based on lightly loaded bearings having adequate lubrication and are listed only as a design guide. More frequent relubrication is required when operating at higher speeds. Actual bearing testing in the specific application should be conducted if the anticipated operating speed approaches the listed limiting speed.

Inch dimensions for reference only.  
 Not all parts are available from stock. Please contact customer service for availability (800) 626-2120.  
 For more information on bearing capabilities outside of our standard offering, please contact Application Engineering (800) 626-2093.

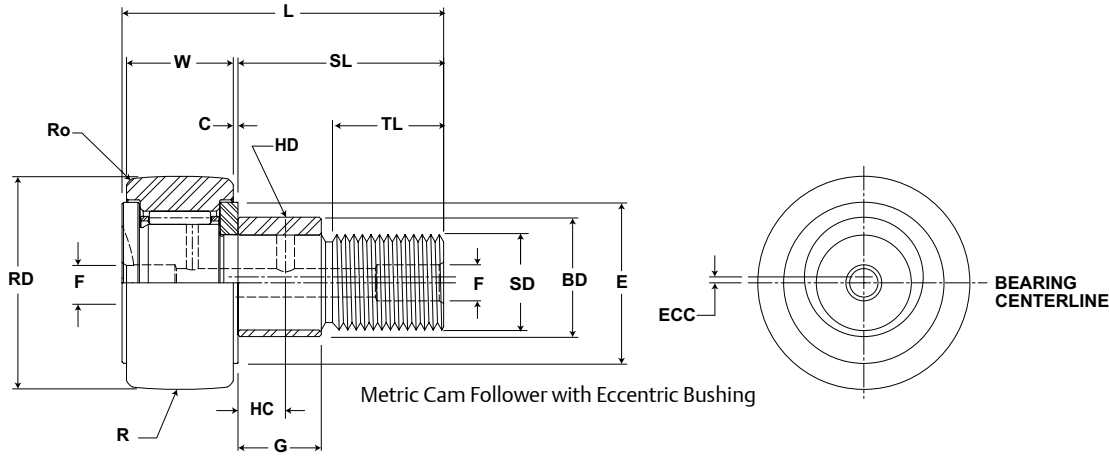

## MCF, MCFE

Part No.		HC	HD	F	H	Ro	E	Housing Bore Diameter		Thread Type	Clamping Torque	Limiting Speed (Grease)	WT
W/O Seals	With LUBRI-DISC Seals	Hole Center	Radial Lub. Hole Diameter	Lub. Hole Dia	Hex Hole Suffix MCF_xx B	Outer Corner	Min. Clamping Diameter						
		(Ref)	(Ref)	(Ref)	(Ref)	(Ref)	(Ref)	Nom.	Tol.				
MCF 80	MCF 80 S	15 .591	4 .157	8 .31	N/A	2.0 .08	63 2.5	30.000 .1811	+0.021/-0 +0.0008/-0	M30x1.5	441 3,903	1,500	1.64 3.62
MCF 80 B	MCF 80 SB			-	14 .55								
MCF 80 X	MCF 80 SX			8 .31	N/A								
MCF 80 BX	MCF 80 SBX			-	14 .55								
MCFE 80	MCFE 80 S	15 .591	4 .157	8 .31	N/A	2.0 .08	63 2.5	35.050 .3799	+0.025/-0 +0.0009/-0	M30x1.5	441 3,903	1,500	1.64 3.62
	MCFE 80 SB			-	14 .55								
	MCFE 80 SX			8 .31	N/A								
	MCFE 80 SBX			-	14 .55								
MCFR 85	MCFR 85 S	15 .591	4 .157	8 .31	N/A	2.0 .08	63 2.5	30.000 .1811	+0.021/-0 +0.0008/-0	M30x1.5	441 3,903	2,200	1.81 3.99
MCFR 85 B	MCFR 85 SB			-	14 .55								
MCFR 85 X	MCFR 85 SX			8 .31	N/A								
MCFR 85 BX	MCFR 85 SBX			-	14 .55								
MCFRE 85	MCFRE 85 S	N/A	N/A	8 .31	N/A	2.0 .08	63 2.5	35.050 .3799	+0.025/-0 +0.0009/-0	M30x1.5	441 3,903	2,200	1.81 3.99
MCFRE 85 B	MCFRE 85 SB			-	14 .55								
MCFRE 85 X	MCFRE 85 SX			8 .31	N/A								
MCFRE 85 BX	MCFRE 85 SBX			-	14 .55								
MCF 90	MCF 90 S	15 .591	4 .157	8 .31	N/A	2.0 .08	68 2.7	30.000 .1811	+0.021/-0 +0.0008/-0	M30x1.5	441 3,903	1,500	1.99 4.39
MCF 90 B	MCF 90 SB			-	14 .55								
MCF 90 X	MCF 90 SX			8 .31	N/A								
MCF 90 BX	MCF 90 SBX			-	14 .55								
MCFE 90	MCFE 90 S	15 .591	4 .157	8 .31	N/A	2.0 .08	68 2.7	35.050 .3799	+0.025/-0 +0.0009/-0	M30x1.5	441 3,903	1,500	1.99 4.39
	MCFE 90 SB			-	14 .55								
	MCFE 90 SX			8 .31	N/A								
	MCFE 90 SBX			-	14 .55								
MCFR 90	MCFR 90 S	15 .591	4 .157	8 .31	N/A	2.0 .08	68 2.7	30.000 .1811	+0.021/-0 +0.0008/-0	M30x1.5	441 3,903	2,200	1.99 4.39
MCFR 90 B	MCFR 90 SB			-	14 .55								
MCFR 90 X	MCFR 90 SX			8 .31	N/A								
MCFR 90 BX	MCFR 90 SBX			-	14 .55								
MCFRE 90	MCFRE 90 S	N/A	N/A	8 .31	N/A	2.0 .08	68 2.7	35.050 .3799	+0.025/-0 +0.0009/-0	M30x1.5	441 3,903	2,200	1.99 4.39
	MCFRE 90 SB			-	14 .55								
	MCFRE 90 SX			8 .31	N/A								
	MCFRE 90 SBX			-	14 .55								

# MCGILL® Metric CAMROL Bearings



**Basic Construction Type:** Yoke Type Crowned / Cylindrical Outside Diameter

**Rolling Elements:** Full Complement / Retained (Caged) Needle Roller

**Bearing Material:** Bearing Quality Steel

**Seal Type:** LUBRI-DISC®

**Lubrication:** Lithium Soap Grease NLGI #2

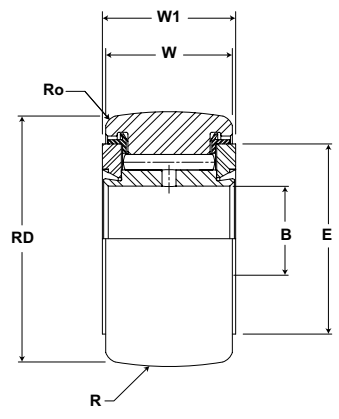

Metric Cam Yoke Roller with Crowned O.D.

## MCYR

Part No.		RD		W		B		W1		R	Track Roller Dynamic Rating	Track Roller Static Rating
W/O Seals	With LUBRI-DISC Seals	Roller Diameter		Roller Width		Bore		Overall Width		Cylindrical Suffix MCYR-X	N/lb	N/lb
		mm inch		mm inch		mm inch		mm inch		mm inch		
		Nom.	Tol.	Nom.	Tol.	Nom	Tol	(Ref)	(Ref)	Radius (Ref)		
MCYR 5	MCYR 5 S	16.000 .6299	0/-0.05 +0/-0.0002	11.00 .433	+0/- .12 +0/- .005	5.000 .1969	+0/- .008 +0/- .0003	12.000 .4724	+0/- .18 +0/- .007	500 20	5,790 1,302	6,900 1,551
MCYR 5 X	MCYR 5 SX		+0/- .008 +0/- .0003							Cylindrical		
MCYRR 5	MCYRR 5 S		0/-0.05 +0/-0.0002							500 20		
MCYR 6	MCYR 6 S	19.000 .7480	0/-0.05 +0/-0.0002	11.00 .433	+0/- .12 +0/- .009	6.000 .2362	+0/- .008 +0/- .0003	12.000 .4724	+0/- .18 +0/- .007	500 20	6,670 1,500	8,760 1,969
MCYR 6 X	MCYR 6 SX		+0/- .009 +0/- .0004							Cylindrical		
MCYRR 6	MCYRR 6 S		0/-0.05 +0/-0.0002							500 20		
MCYR 8	MCYR 8 S	24.000 0.9449	0/-0.05 +0/-0.0002	14.00 .551	+0/- .12 +0/- .013	8.000 .3150	+0/- .008 +0/- .0003	15.000 .5906	+0/- .18 +0/- .007	500 20	9,610 2,161	12,600 2,833
MCYR 8 X	MCYR 8 SX		+0/- .009 +0/- .0004							Cylindrical		
MCYRR 8	MCYRR 8 S		0/-0.05 +0/-0.0002							500 20		
MCYR 10	MCYR 10 S	30.000 1.1811	0/-0.05 +0/-0.0002	14.00 .551	+0/- .12 +0/- .017	10.000 .3937	+0/- .008 +0/- .0003	15.000 .5906	+0/- .18 +0/- .007	500 20	11,080 2,491	15,300 3,440
MCYR 10 X	MCYR 10 SX		+0/- .009 +0/- .0004							Cylindrical		
MCYRR 10	MCYRR 10 S		0/-0.05 +0/-0.0002							500 20		
MCYR 12	MCYR 12 S	32.000 1.2598	0/-0.05 +0/-0.0002	14.00 .551	+0/- .12 +0/- .021	12.000 .4724	+0/- .008 +0/- .0003	15.000 .5906	+0/- .18 +0/- .007	500 20	12,060 2,711	17,400 3,912
MCYR 12 X	MCYR 12 SX		+0/- .011 +0/- .0004							Cylindrical		
MCYRR 12	MCYRR 12 S		0/-0.05 +0/-0.0002							500 20		
MCYR 15	MCYR 15 S	35.000 1.3780	0/-0.05 +0/-0.0002	18.00 .709	+0/- .12 +0/- .025	15.000 .5906	+0/- .008 +0/- .0003	19.000 .7480	+0/- .21 +0/- .008	500 20	16,970 3,815	28,500 6,407
MCYR 15 X	MCYR 15 SX		+0/- .011 +0/- .0004							Cylindrical		
MCYRR 15	MCYRR 15 S		0/-0.05 +0/-0.0002							500 20		
MCYR 17	MCYR 17 S	40.000 1.5748	0/-0.05 +0/-0.0002	20.00 .787	+0/- .12 +0/- .029	17.000 .6693	+0/- .008 +0/- .0003	21.000 .8268	+0/- .21 +0/- .008	500 20	19,420 4,366	32,200 7,239
MCYR 17 X	MCYR 17 SX		+0/- .011 +0/- .0004							Cylindrical		
MCYRR 17	MCYRR 17 S		0/-0.05 +0/-0.0002							500 20		
MCYR 17 X	MCYR 17 SX		+0/- .011 +0/- .0004							Cylindrical		

1. Standard bearing has a crowned roller outside diameter. For straight cylindrical outside roller diameter, add suffix "X". Example - MCFR-35-X or MCF-35-SX.  
 2. Clamping torque is based on dry threads. If threads are lubricated, use half of value shown.  
 3. Static load rating is based on stud strength or on internal rolling element load distribution stresses.

Inch dimensions for reference only.  
 Not all parts are available from stock. Please contact customer service for availability (800) 626-2120.  
 For more information on bearing capabilities outside of our standard offering, please contact Application Engineering (800) 626-2093.

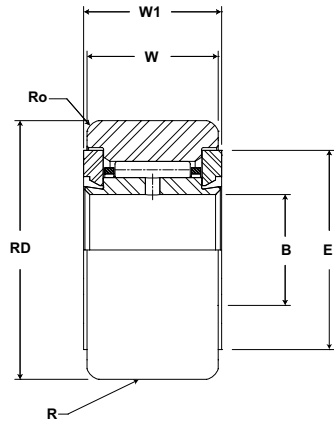

Metric Cam Yoke Roller with Cylindrical O.D.

## MCYR

Part No.		E	Ro	LF	LFT	TF	TFT	Limiting Speed	WT	
W/O Seals	With LUBRI-DISC Seals	Min. Clamping Diameter	Outer Corner	Recommended Shaft Diameters					RPM	Bearing Weight
				Loose Fit (for light loads) g6		Light Fit (for medium loads) h6				kg lb
		mm inch		mm inch		mm inch				
(Ref)	(Ref)	Nom.	Tol.	Nom.	Tol.					
MCYR 5	MCYR 5 S	11 .4	.30 .012	4.996 .1967	+0/-0.008 +0/-0.0003	5.000 .1968	+0/-0 +0/-0.00	13,000	.01 .02	
MCYR 5 X	MCYR 5 SX							19,500		
MCYR 6	MCYR 6 S	13 .5	.30 .012	5.996 .2361	+0/-0.008 +0/-0.0003	6.000 .2362	+0/-0 +0/-0.00	10,500	.02 .04	
MCYR 6 X	MCYR 6 SX							15,500		
MCYR 8	MCYR 8 S	16 .6	.50 .020	7.995 .3148	+0/-0.009 +0/-0.0004	8.000 .3149	+0/-0 +0/-0.00	8,400	.04 .09	
MCYR 8 X	MCYR 8 SX							12,500		
MCYR 10	MCYR 10 S	19 .7	1.00 .039	9.995 .3935	+0/-0.009 +0/-0.0004	10.000 .3937	+0/-0 +0/-0.00	6,400	.06 .13	
MCYR 10 X	MCYR 10 SX							9,600		
MCYR 12	MCYR 12 S	21 .8	1.00 .039	11.994 .4722	+0/-0.011 +0/-0.0004	12.000 .4724	+0/-0 +0/-0.00	6,400	.07 .15	
MCYR 12 X	MCYR 12 SX							9,600		
MCYR 15	MCYR 15 S	24 0.9	1.00 .039	14.994 .5903	+0/-0.011 +0/-0.0004	15.000 .5905	+0/-0 +0/-0.00	4,200	.10 .22	
MCYR 15 X	MCYR 15 SX							6,300		
MCYR 17	MCYR 17 S	27 1.1	1.50 .059	16.994 .6691	+0/-0.011 +0/-0.0004	17.000 .6692	+0/-0 +0/-0.00	3,300	.15 .33	
MCYR 17 X	MCYR 17 SX							5,000		

For a tight fit and heavy loads, us ISO tolerance J6.

# MCGILL® Metric CAMROL Bearings



**Basic Construction Type:** Yoke Type Crowned / Cylindrical Outside Diameter

**Rolling Elements:** Full Complement / Retained (Caged) Needle Roller

**Bearing Material:** Bearing Quality Steel

**Seal Type:** LUBRI-DISC®

**Lubrication:** Lithium Soap Grease NLGI #2

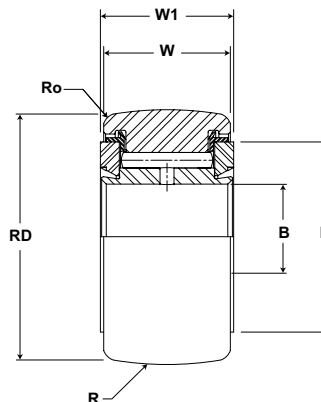

Metric Cam Yoke Roller with Crowning O.D.

## MCYR

Part No.		RD		W		B		W1		R	Track Roller Dynamic Rating	Track Roller Static Rating
W/O Seals	With LUBRI-DISC Seals	Roller Diameter		Roller Width		Bore		Overall Width		Cylindrical Suffix MCYR-X	N/lb	N/lb
		mm inch		mm inch		mm inch		mm inch		mm inch		
		Nom.	Tol.	Nom.	Tol.	Nom	Tol	(Ref)	(Ref)	Radius (Ref)		
MCYR 20	MCYR 20 S	47.000 1.8504	0/-0.05 +0/-0.0002	24.00 .945	+0/- .12 +0/- .033	20.000 .7874	+0/- .010 +0/- .0004	25.000 .9843	+0/- .21 +0/- .008	500 20	25,690 5,776	48,000 10,791
MCYR 20 X	MCYR 20 SX		+0/- .011 +0/- .0004							Cylindrical		
MCYRR 20	MCYRR 20 S	47.000 1.8504	0/-0.05 +0/-0.0002	24.00 .945	+0/- .12 +0/- .033	20.000 .7874	+0/- .010 +0/- .0004	25.000 .9843	+0/- .21 +0/- .008	500 20	17,750 3,991	29,800 6,700
MCYRR 20 X	MCYRR 20 SX		+0/- .011 +0/- .0004							Cylindrical		
MCYR 25	MCYR 25 S	52.000 2.0472	0/-0.05 +0/-0.0002	24.00 .945	+0/- .12 +0/- .037	25.000 .9843	+0/- .010 +0/- .0004	25.000 .9843	+0/- .21 +0/- .008	500 20	28,440 6,394	58,700 13,197
MCYR 25 X	MCYR 25 SX		+0/- .013 +0/- .0005							Cylindrical		
MCYRR 25	MCYRR 25 S	52.000 2.0472	0/-0.05 +0/-0.0002	24.00 .945	+0/- .12 +0/- .037	25.000 .9843	+0/- .010 +0/- .0004	25.000 .9843	+0/- .21 +0/- .008	500 20	19,120 4,299	34,900 7,846
MCYRR 25 X	MCYRR 25 SX		+0/- .013 +0/- .0005							Cylindrical		
MCYR 30	MCYR 30 S	62.000 2.4409	0/-0.05 +0/-0.0002	29.00 1.142	+0/- .12 +0/- .041	30.000 1.1811	+0/- .010 +0/- .0004	29.000 1.1417	+0/- .21 +0/- .008	500 20	41,480 9,326	89,000 20,009
MCYR 30 X	MCYR 30 SX		+0/- .013 +0/- .0005							Cylindrical		
MCYRR 30	MCYRR 30 S	62.000 2.4409	0/-0.05 +0/-0.0002	29.00 1.142	+0/- .12 +0/- .041	30.000 1.1811	+0/- .010 +0/- .0004	29.000 1.1417	+0/- .21 +0/- .008	500 20	28,340 6,371	54,300 12,208
MCYRR 30 X	MCYRR 30 SX		+0/- .013 +0/- .0005							Cylindrical		
MCYR 35	MCYR 35 S	72.000 2.8346	0/-0.05 +0/-0.0002	29.00 1.142	+0/- .12 +0/- .045	35.000 1.3780	+0/- .012 +0/- .0005	29.000 1.1417	+0/- .21 +0/- .008	500 20	47,370 10,650	10,000 2,248
MCYR 35 X	MCYR 35 SX		+0/- .013 +0/- .0005							Cylindrical		
MCYRR 35	MCYRR 35 S	72.000 2.8346	0/-0.05 +0/-0.0002	29.00 1.142	+0/- .12 +0/- .045	35.000 1.3780	+0/- .012 +0/- .0005	29.000 1.1417	+0/- .21 +0/- .008	500 20	32,460 7,298	60,900 13,692
MCYRR 35 X	MCYRR 35 SX		+0/- .013 +0/- .0005							Cylindrical		
MCYR 40	MCYR 40 S	80.000 3.1496	0/-0.05 +0/-0.0002	35.00 1.378	+0/- .12 +0/- .049	40.000 1.5748	+0/- .012 +0/- .0005	32.000 1.2598	+0/- .25 +0/- .010	500 20	58,350 13,118	123,000 27,653
MCYR 40 X	MCYR 40 SX		+0/- .015 +0/- .0006							Cylindrical		
MCYRR 40	MCYRR 40 S	80.000 3.1496	0/-0.05 +0/-0.0002	35.00 1.378	+0/- .12 +0/- .049	40.000 1.5748	+0/- .012 +0/- .0005	32.000 1.2598	+0/- .25 +0/- .010	500 20	41,480 9,326	78,700 17,693
MCYRR 40 X	MCYRR 40 SX		+0/- .015 +0/- .0006							Cylindrical		
MCYR 45	MCYR 45 S	85.000 3.3465	0/-0.05 +0/-0.0002	35.00 1.378	+0/- .12 +0/- .053	45.000 1.7717	+0/- .012 +0/- .0005	32.000 1.2598	+0/- .25 +0/- .010	500 20	61,490 13,824	136,000 30,576
MCYR 45 X	MCYR 45 SX		+0/- .015 +0/- .0006							Cylindrical		
MCYRR 45	MCYRR 45 S	85.000 3.3465	0/-0.05 +0/-0.0002	35.00 1.378	+0/- .12 +0/- .053	45.000 1.7717	+0/- .012 +0/- .0005	32.000 1.2598	+0/- .25 +0/- .010	500 20	42,760 9,613	84,100 18,907
MCYRR 45 X	MCYRR 45 SX		+0/- .015 +0/- .0006							Cylindrical		
MCYR 50	MCYR 50 S	90.000 3.5433	0/-0.05 +0/-0.0002	35.00 1.378	+0/- .12 +0/- .057	50.000 1.9685	+0/- .012 +0/- .0005	32.000 1.2598	+0/- .25 +0/- .010	500 20	64,330 14,463	148,000 33,273
MCYR 50 X	MCYR 50 SX		+0/- .015 +0/- .0006							Cylindrical		
MCYRR 50	MCYRR 50 S	90.000 3.5433	0/-0.05 +0/-0.0002	35.00 1.378	+0/- .12 +0/- .057	50.000 1.9685	+0/- .012 +0/- .0005	32.000 1.2598	+0/- .25 +0/- .010	500 20	45,600 10,252	94,800 21,313
MCYRR 50 X	MCYRR 50 SX		+0/- .015 +0/- .0006							Cylindrical		

1. Standard bearing has a crowned roller outside diameter. For straight cylindrical outside roller diameter, add suffix "X". Example - MCFR-35-X or MCF-35-SX.

2. Clamping torque is based on dry threads. If threads are lubricated, use half of value shown.

3. Static load rating is based on stud strength or on internal rolling element load distribution stresses.

Inch dimensions for reference only.

Not all parts are available from stock. Please contact customer service for availability (800) 626-2120.

For more information on bearing capabilities outside of our standard offering, please contact Application Engineering (800) 626-2093.

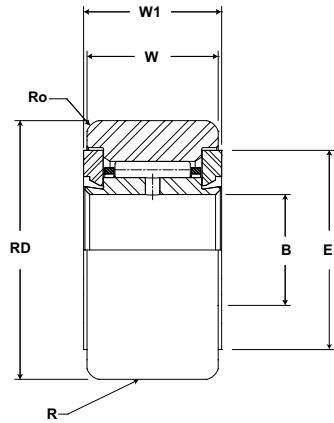

Metric Cam Yoke Roller with Cylindrical O.D.

## MCYR

Part No.		E	Ro	LF	LFT	TF	TFT	Limiting Speed	WT
W/O Seals	With LUBRI-DISC Seals	Min. Clamping Diameter	Outer Corner	Recommended Shaft Diameters					RPM
		mm inch	mm inch	Loose Fit (for light loads) g6		Light Fit (for medium loads) h6		kg lb	
				(Ref)	(Ref)	Nom.	Tol.		Nom.
MCYR 20	MCYR 20 S	30 1.2	1.50 .059	19.993 .7871	+0/-0.013 +0/-0.0005	20.000 .7874	+0/-0 +0/-0.00	2,600	.25 .55
MCYR 20 X	MCYR 20 SX							3,900	
MCYRR 20	MCYRR 20 S	36 1.4	1.50 .059	24.993 .9840	+0/-0.013 +0/-0.0005	25.000 .9842	+0/-0 +0/-0.00	2,600	.29 .64
MCYR 25 X	MCYR 25 SX							3,900	
MCYRR 25	MCYRR 25 S	44 1.7	2.00 .079	29.993 1.1808	+0/-0.013 +0/-0.0005	30.000 1.1811	+0/-0 +0/-0.00	2,100	.47 1.04
MCYR 30 X	MCYR 30 SX							3,100	
MCYRR 30	MCYRR 30 S	52 2.0	2.00 .079	34.991 1.3776	+0/-0.016 +0/-0.0006	35.000 1.3779	+0/-0 +0/-0.00	2,100	.64 1.41
MCYR 35 X	MCYR 35 SX							3,100	
MCYRR 35	MCYRR 35 S	58 2.3	2.00 .079	39.991 1.5744	+0/-0.016 +0/-0.0006	40.000 1.5748	+0/-0 +0/-0.00	1,500	.84 1.84
MCYR 40 X	MCYR 40 SX							2,200	
MCYRR 40	MCYRR 40 S	63 2.5	2.00 .079	44.991 1.7713	+0/-0.016 +0/-0.0006	45.000 1.7716	+0/-0 +0/-0.00	1,500	.90 1.99
MCYR 45 X	MCYR 45 SX							2,200	
MCYRR 45	MCYRR 45 S	68 2.7	2.00 .079	45.991 1.8107	+0/-0.016 +0/-0.0006	50.000 1.9685	+0/-0 +0/-0.00	1,500	.97 2.14
MCYR 50 X	MCYR 50 SX							2,200	
MCYRR 50	MCYRR 50 S								
MCYR 50 X	MCYR 50 SX								

For a tight fit and heavy loads, us ISO tolerance J6.

## Heavy-Duty Inch and Metric CAMROL®

McGill Heavy-Duty CAMROL bearings are full complement cylindrical roller bearings featuring black oxide treated bearing steel, available in two basic mounting styles (stud or yoke) for use mechanical automation or linear motion applications. Our standard integral flange construction of stud version bearings helps maintain bearing integrity throughout the life. The inch series utilizes a rubber lip seal to provide a barrier for contamination and lubricant retention. Within the following section you can learn more about how these features and others can be applied to your application.

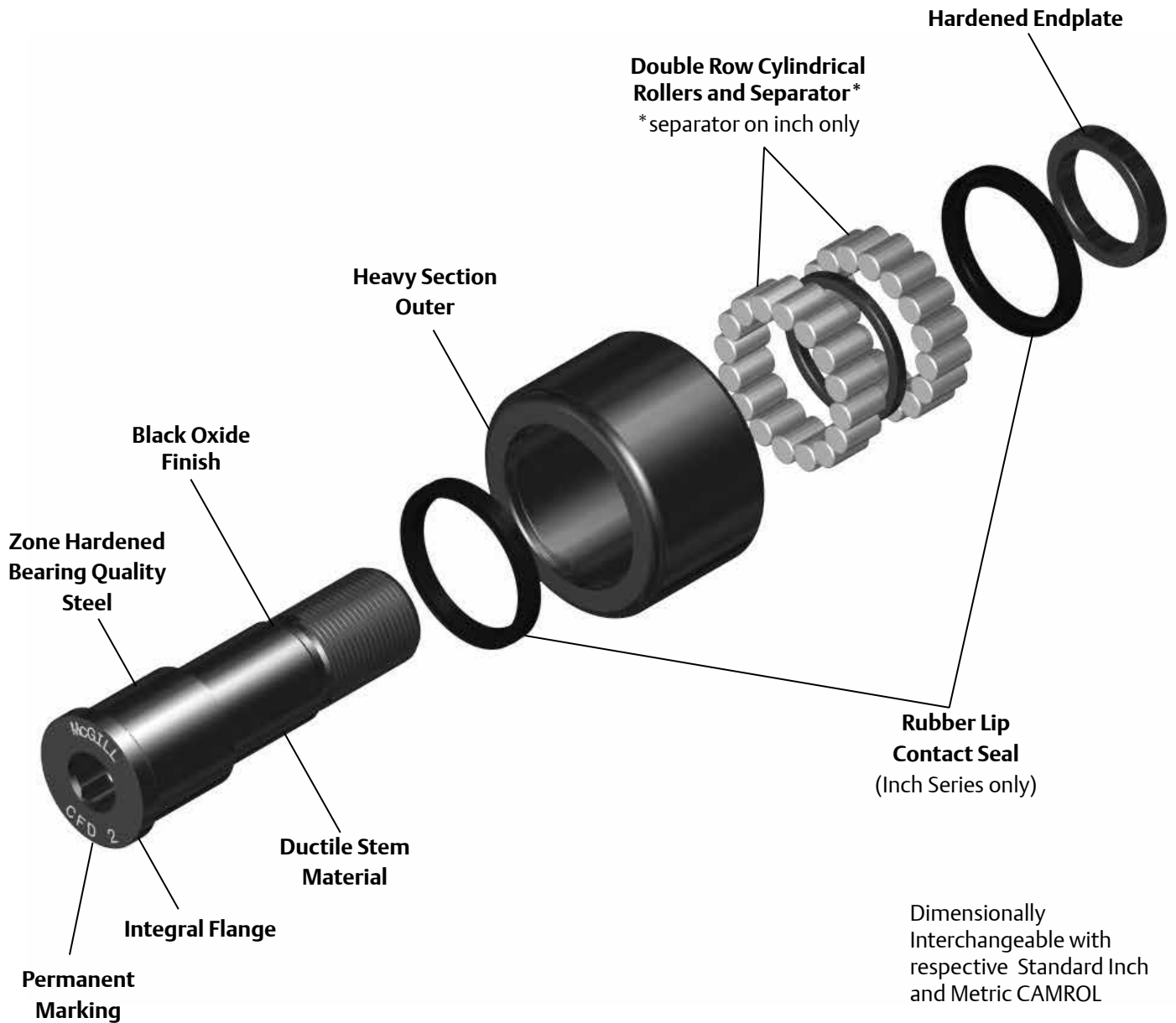

# Cam Follower Inch and Metric Nomenclature

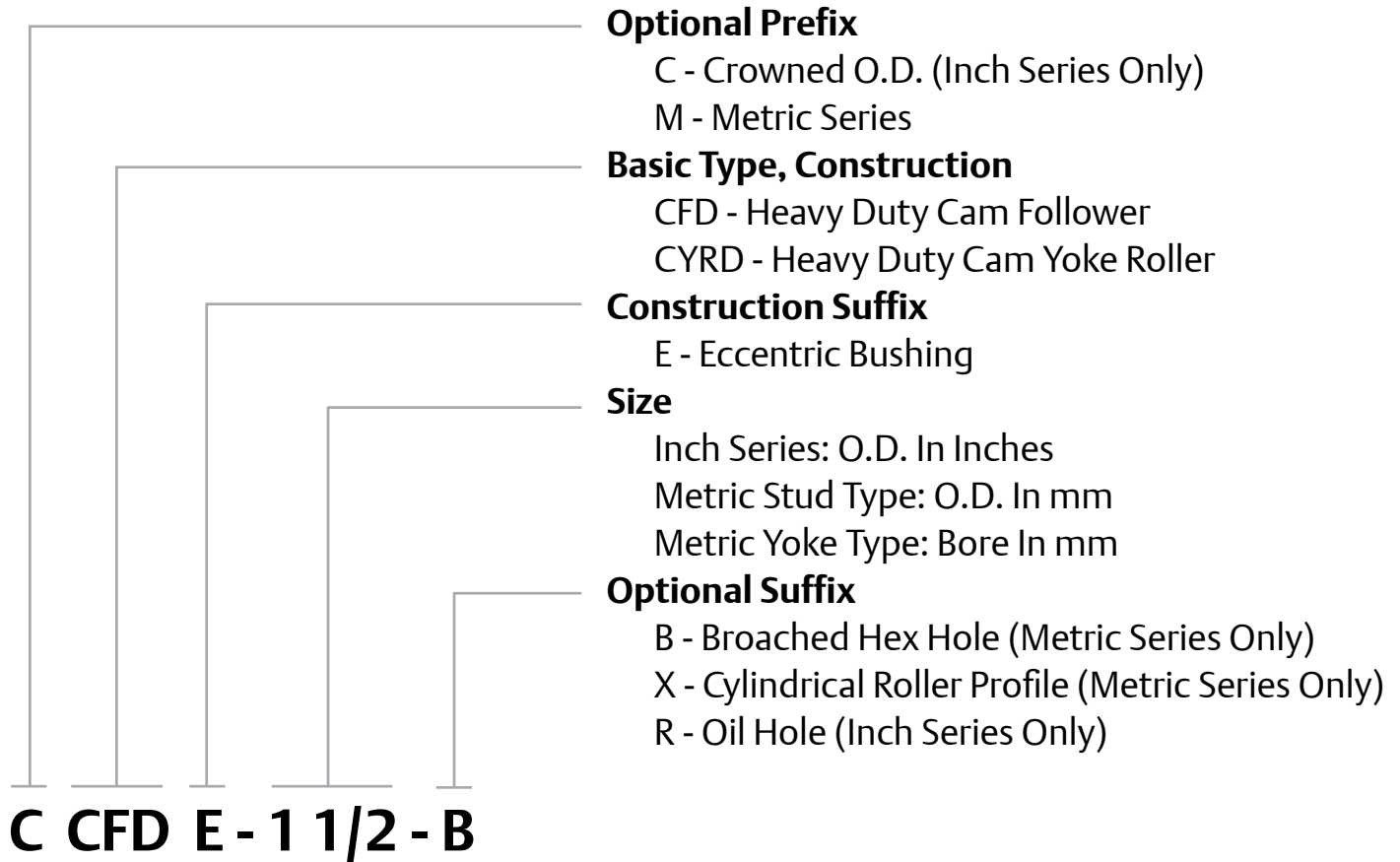



## Features and Benefits

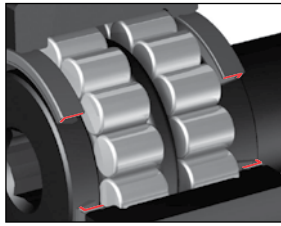

### Double Row Full Complement Needle Rollers

The roller diameter to length ratio of Cylindrical rollers provides an end face and increases surface area to help support incidental thrust loads.

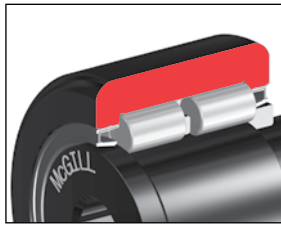

### Heavy Section Outer

The heavy section outer helps support radial loading and provide proper rolling element support.

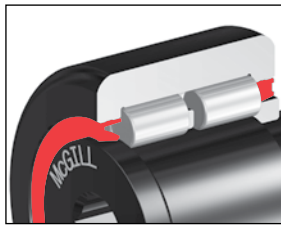

### Rubber Lip Seals - Inch Series

Heavy-Duty CAMROL® Bearings have rubber lip seals to help keep contamination out and lubricant in. The seals are mounted inward to improve grease retention. Inch Only, removed as option- NS

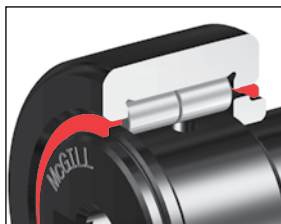

### Metallic Shields - Metric Series

The metric series Heavy-Duty bearings metallic side shields providing a barriers to help retain grease and keep out contaminants. Metric Only, removed as option – NS

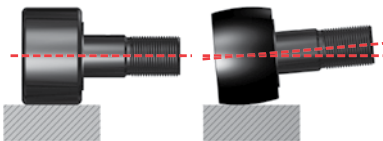

### Crowned Outside Diameter (OD)

A crown on the OD of a cam follower bearing can increase bearing life versus a standard cylindrical cam follower. The crown achieves this performance by helping to distribute the stress on the outer ring and rolling elements resulting from misalignment due to mounting inaccuracy or stud deflection. The crown also helps reduce outer skidding in turntable or rotary applications. Not all applications may see the benefit of a crowned OD, consult Application Engineering for guidance for your application. Crowned OD is an option for Inch Series. Crowned OD is standard for Metric Series.

## Features and Benefits continued



### Cylindrical Outside Diameter (OD)

The cylindrical OD can improve performance in certain applications such as improved track capacity by maximizing the contact area with the track. Cylindrical OD is standard for Inch Series. Cylindrical OD is an option for Metric Series.



### Zone Hardened Raceways

Heat treatment used to precisely harden working surfaces of the raceway and flange. The hardened surfaces provide support for the rolling element contact stresses, while keeping the core of the inner ductile to help absorb shock loads.

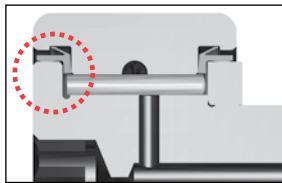

### Integral Flange

The integral flange helps maintain bearing integrity throughout the bearing life. Zone hardened to provide wear resistance from incidental contact with the outer or rollers, and provides a sealing surface for rubber lipped seal.



### Hex Hole (Broached)

The hex hole can aid in the installation and removal of stud type cam followers by increasing the holding power over a standard screw driver slot.

\*Standard on inch, option on Metric.

## Features and Benefits continued

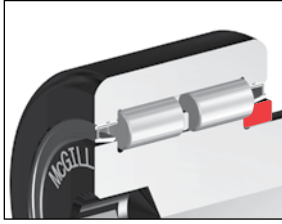

### Hardened Endplate

Similar to the flange, the endplate must provide a contact surface for the seal and resist wear from incidental contact with the outer or rollers.

### Factory Grease Fill

The cam follower and cam yoke roller bearings are factory lubricated with a medium temperature grease. Contact Application Engineering when application conditions require special lubricants.

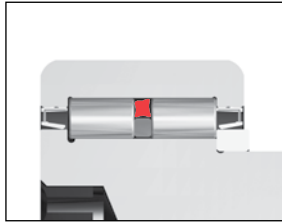

### Lubrication Reservoir

The inch series heavy-Duty bearings incorporate a spacer, resulting in an increased lubricant reservoir. Inch only



### Black Oxide Finish

Bearings have a black oxide finish on all external surfaces.

## Options



### Permanent Marking

Part number permanently marked on bearing face, helps bearing identification after years of service.

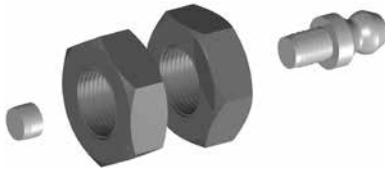

### Installation Accessory Pack - Metric Series Stud Type

All McGill Metric Cam followers include (2) oil hole plug to help provide proper lubrication path to the rolling elements and prevent contamination from entering the bearing through a unused oil hole. Metric only, Inch as -OH option,

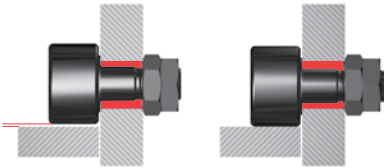

### Eccentric Stud

Eccentric stud option provides a means of adjusting the radial position of the bearing, which can improve the load sharing of inline bearing combinations. Cam follower load sharing helps reduce operation costs by reducing premature failures due to overloaded bearings, the need of precise mounting hole location tolerances and providing ability to realign bearing due to track wear.

## Additional Options



### BHT

Broached (Hex) hole at threaded end of cam follower stud.



### THT

Threaded axial lubrication hole at threaded end of cam follower stud.



### THF

Threaded axial lubrication hole at flanged end of cam follower stud. Available with all screw driver slot cam followers or broached cam followers over 3".



### THB

Threaded axial oil hole on both ends of cam follower stud. Available with all screw driver slot cam followers or broached cam followers over 3".



### ALG

Annular lubrication groove at cam follower stem radial lubrication hole.

## **Custom Capabilities**

- *Customer specified factory grease fill*
- *Grease fitting installed*
- *Stud or thread length modifications*
- *Roller diameter variations or tolerances*
- *Cam followers grouped or matched diameter tolerance / run out sets*
- *Custom engineered to order designs*

# MCGILL® Heavy Duty CAMROL Bearings



- Basic Construction Type:** Stud Type Crowned / Cylindrical Outside Diameter
- Rolling Elements:** Full Complement Cylindrical Roller
- Bearing Material:** Bearing Quality Steel
- Seal Type:** LUBRI-DISC
- Lubrication:** Lithium Soap Grease NLGI #2
- System Configuration:** Concentric / Eccentric / Heavy Stud
- Mounting Feature:** Slot / Hex Hole

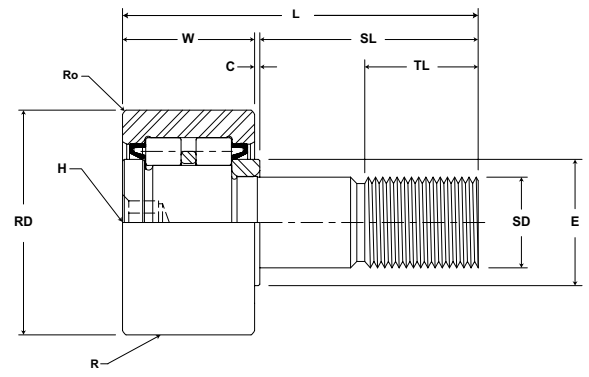

## CFD

Part No.	RD		W		SD		SL	C	TL	L	R	Track Roller Dynamic Rating lb/N	Track Roller Static Rating lb/N
	Roller Diameter		Roller Width		Stud Diameter		Stud Length	Endplate Extension	Minimum Thread Length	Length Overall	Crown Prefix CCFD		
	inch mm	inch mm	inch mm	inch mm	inch mm	inch mm	inch mm	inch mm	inch mm	inch mm			
With Seals	Nom.	Tol.	Nom.	Tol.	Nom.	Tol.	(Ref)	(Ref)	(Ref)	(Ref)	Radius		
CFD 1 1/4	1.250	+0/-0.001	.750	+0/-0.001	.500	+0/-0.001	1.25	.03	.63	2.03	Cylindrical	3,300 14,680	2,400 10,680
CCFD 1 1/4	31.75	+0/-0.03	19.05	+0/-0.03	12.70	+0/-0.03	31.8	.8	15.9	51.6	14 356		
CFD 1 3/8	1.375	+0/-0.001	.750	+0/-0.001	.500	+0/-0.001	1.25	.03	.63	2.03	Cylindrical	3,600 16,000	2,400 10,680
CCFD 1 3/8	34.93	+0/-0.03	19.05	+0/-0.03	12.70	+0/-0.03	31.8	.8	15.9	51.6	14 356		
CFD 1 1/2	1.500	+0/-0.001	.875	+0/-0.001	.625	+0/-0.001	1.50	.03	.75	2.41	Cylindrical	5,000 22,240	4,100 18,240
CCFD 1 1/2	38.10	+0/-0.03	22.23	+0/-0.03	15.88	+0/-0.03	38.1	.8	19.1	61.1	20 508		
CFD 1 5/8	1.625	+0/-0.001	.875	+0/-0.001	.625	+0/-0.001	1.50	.03	.75	2.41	Cylindrical	5,400 24,020	4,100 18,240
CCFD 1 5/8	41.28	+0/-0.03	22.23	+0/-0.03	15.88	+0/-0.03	38.1	.8	19.1	61.1	20 508		
CFD 1 3/4	1.750	+0/-0.001	1.000	+0/-0.001	.750	+0/-0.001	1.75	.03	.88	2.78	Cylindrical	6,650 29,580	6,100 27,130
CCFD 1 3/4	44.45	+0/-0.03	25.40	+0/-0.03	19.05	+0/-0.03	44.5	.8	22.2	70.6	20 508		
CFD 1 7/8	1.875	+0/-0.001	1.000	+0/-0.001	.750	+0/-0.001	1.75	.03	.88	2.78	Cylindrical	7,100 31,580	6,100 27,130
CCFD 1 7/8	47.63	+0/-0.03	25.40	+0/-0.03	19.05	+0/-0.03	44.5	.8	22.2	70.6	20 508		
CFD 2	2.000	+0/-0.001	1.250	+0/-0.001	.875	+0/-0.001	2.00	.03	1.00	3.28	Cylindrical	9,500 42,260	8,300 36,920
CCFD 2	50.80	+0/-0.03	31.75	+0/-0.03	22.23	+0/-0.03	50.8	.8	25.4	83.3	24 610		
CFD 2 1/4	2.250	+0/-0.001	1.250	+0/-0.001	.875	+0/-0.001	2.00	.03	1.00	3.28	Cylindrical	10,500 46,700	8,300 36,920
CCFD 2 1/4	57.15	+0/-0.03	31.75	+0/-0.03	22.23	+0/-0.03	50.8	.8	25.4	83.3	24 610		

Clamping torque is based on dry threads. If threads are lubricated, use half of value shown.

Metric dimensions for reference only.  
 Not all parts are available from stock. Please contact customer service for availability (800) 626-2120.  
 For more information on bearing capabilities outside of our standard offering, please contact Application Engineering (800) 626-2093.

# Heavy Duty CAMROL Bearings **McGILL**



CFD

Part No.	H		E		Ro		Housing Bore Diameter	Thread Type	Clamping Torque		WT			
	Hex Hole		Min. Clamping Diameter		Corner				Clamping Torque		Bearing Weight			
	inch mm		(Ref)		(Ref)				inch mm		in-lb Nm		lb kg	
	Size								Nom. Tol.					
CFD 1 1/4	.25	.98	.03	25.0	.8	12.708	.5003	1/2-20	350	40	.29	.13		
CCFD 1 1/4	6.4	25.0	N/A										+0.002/-0.0003	+0.0005/-0.0008
CFD 1 3/8	.25	.98	.05	25.0	1.2	12.708	.5003	1/2-20	350	40	.35	.16		
CCFD 1 3/8	6.4	25.0	N/A										+0.002/-0.0003	+0.0005/-0.0012
CFD 1 1/2	.312	1.09	.06	27.8	1.6	15.883	.6253	5/8-18	650	73	.50	.22		
CCFD 1 1/2	7.9	27.8	N/A										+0.002/-0.0003	+0.0005/-0.0016
CFD 1 5/8	.312	1.09	.06	27.8	1.6	15.883	.6253	5/8-18	650	73	.58	.26		
CCFD 1 5/8	7.9	27.8	N/A										+0.002/-0.0003	+0.0005/-0.0020
CFD 1 3/4	.312	1.25	.06	31.8	1.6	19.058	.7503	3/4-16	1,250	141	.81	.37		
CCFD 1 3/4	7.9	31.8	N/A										+0.002/-0.0003	+0.0005/-0.0024
CFD 1 7/8	.312	1.25	.06	31.8	1.6	19.058	.7503	3/4-16	1,250	141	.91	.41		
CCFD 1 7/8	7.9	31.8	N/A										+0.002/-0.0003	+0.0005/-0.0028
CFD 2	.437	1.41	.09	35.7	2.4	22.233	.8753	7/8-14	1,500	170	1.29	.59		
CCFD 2	11.1	35.7	N/A										+0.002/-0.0003	+0.0005/-0.0032
CFD 2 1/4	.437	1.41	.09	35.7	2.4	22.233	.8753	7/8-14	1,500	170	1.59	.72		
CCFD 2 1/4	11.1	35.7	N/A										+0.002/-0.0003	+0.0005/-0.0036

Clamping torque is based on dry threads. If threads are lubricated, use half of value shown.



# MCGILL® Heavy Duty CAMROL Bearings



- Basic Construction Type:** Stud Type Crowned / Cylindrical Outside Diameter
- Rolling Elements:** Full Complement Cylindrical Roller
- Bearing Material:** Bearing Quality Steel
- Seal Type:** LUBRI-DISC®
- Lubrication:** Lithium Soap Grease NLGI #2
- System Configuration:** Concentric / Eccentric / Heavy Stud
- Mounting Feature:** Slot / Hex Hole

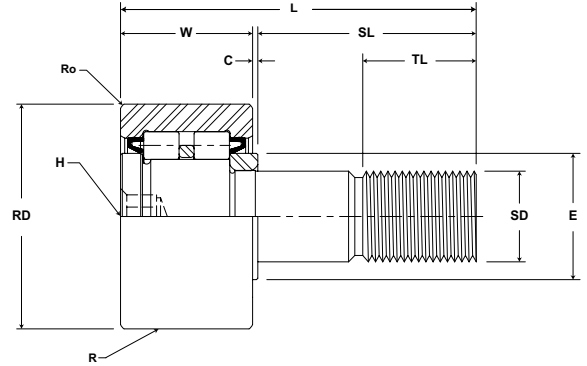

## CFD

Part No.	RD		W		SD		SL	C	TL	L	R	Track Roller Dynamic Rating lb/N	Track Roller Static Rating lb/N
	Roller Diameter		Roller Width		Stud Diameter		Stud Length	Endplate Extension	Minimum Thread Length	Length Overall	Crown Prefix CCFD		
	inch mm	inch mm	inch mm	inch mm	inch mm	inch mm	inch mm	inch mm	inch mm	inch mm	Radius		
	Nom.	Tol.	Nom.	Tol.	Nom.	Tol.	(Ref)	(Ref)	(Ref)	(Ref)	Radius		
CFD 2 1/2	2.500	+0/-0.001	1.500	+0/-0.001	1.000	+0/-0.001	2.25	.03	1.125	3.78	Cylindrical	14,000 62,270	10,400 46,260
CCFD 2 1/2	63.50	+0/-0.03	38.10	+0/-0.03	25.40	+0/-0.03	57.2	.8	28.6	96.0	30 762		
CFD 2 3/4	2.750	+0/-0.001	1.500	+0/-0.001	1.000	+0/-0.001	2.25	.03	1.125	3.78	Cylindrical	15,000 66,720	10,400 46,260
CCFD 2 3/4	69.85	+0/-0.03	38.10	+0/-0.03	25.40	+0/-0.03	57.2	.8	28.6	96.0	30 762		
CFD 3	3.000	+0/-0.001	1.750	+0/-0.001	1.250	+0/-0.001	2.50	.03	1.25	4.28	Cylindrical	18,300 81,400	18,100 80,510
CCFD 3	76.20	+0/-0.03	44.45	+0/-0.03	31.75	+0/-0.03	63.5	.8	31.7	108.7	30 762		
CFD 3 1/4	3.250	+0/-0.001	1.750	+0/-0.001	1.250	+0/-0.001	2.50	.03	1.25	4.28	Cylindrical	20,300 90,290	18,100 80,510
CCFD 3 1/4	82.55	+0/-0.03	44.45	+0/-0.03	31.75	+0/-0.03	63.5	.8	31.7	108.7	30 762		
CFD 3 1/2	3.500	+0/-0.001	2.000	+0/-0.001	1.375	+0/-0.001	2.75	.03	1.375	4.78	Cylindrical	23,700 105,420	21,500 95,630
CCFD 3 1/2	88.90	+0/-0.03	50.80	+0/-0.03	34.93	+0/-0.03	69.9	.8	34.9	121.4	30 762		
CFD 4	4.000	+0/-0.001	2.250	+0/-0.001	1.500	+0/-0.001	3.50	.03	1.50	5.78	Cylindrical	32,500 144,560	22,800 101,410
CCFD 4	101.60	+0/-0.03	57.15	+0/-0.03	38.10	+0/-0.03	88.9	.8	38.1	146.8	30 762		
CFD 5	5.000	+0/-0.001	2.750	+0/-0.001	2.000	+0/-0.001	5.06	.06	2.00	7.88	Cylindrical	50,500 224,620	50,800 225,960
CCFD 5	127.00	+0/-0.03	69.85	+0/-0.03	50.80	+0/-0.03	128.6	1.6	50.4	200.0	48 1,219		
CFD 6	6.000	+0/-0.001	3.250	+0/-0.001	2.500	+0/-0.001	6.00	.06	2.50	9.31	Cylindrical	71,500 318,030	86,100 382,970
CCFD 6	152.40	+0/-0.03	82.55	+0/-0.03	63.50	+0/-0.03	152.4	1.6	63.5	236.5	30 762		

Metric dimensions for reference only.

Not all parts are available from stock. Please contact customer service for availability (800) 626-2120.

For more information on bearing capabilities outside of our standard offering, please contact Application Engineering (800) 626-2093.

# Heavy Duty CAMROL Bearings **McGILL**



CFD

Part No.	H		E		Ro		Housing Bore Diameter	Thread Type	Clamping Torque		WT			
	Hex Hole		Min. Clamping Diameter		Corner				Clamping Torque		Bearing Weight			
	inch mm				inch mm						in-lb Nm		lb kg	
	Size		(Ref)		(Ref)				Nom. Tol.					
CFD 2 1/2	.50		1.69		.09		1.0003		1-14		2.38			
CCFD 2 1/2	12.7		42.9		2.4		25.408 +.0002/-0.0003 +.0005/-0.0040				1.08			
CFD 2 3/4	.50		1.69		.09		1.0003		1-14		2.93			
CCFD 2 3/4	12.7		42.9		2.4		25.408 +.0002/-0.0003 +.0005/-0.0044				1.33			
CFD 3	.75		2.13		.13		1.2503		1 1/4-12		4.20			
CCFD 3	19.1		54.0		3.2		31.758 +.0002/-0.0003 +.0005/-0.0048				1.91			
CFD 3 1/4	.75		2.13		.13		1.2503		1 1/4-12		4.52			
CCFD 3 1/4	19.1		54.0		3.2		31.758 +.0002/-0.0003 +.0005/-0.0052				2.05			
CFD 3 1/2	.75		2.44		.13		1.3753		1 3/8-12		5.99			
CCFD 3 1/2	19.1		61.9		3.2		34.933 +.0002/-0.0003 +.0005/-0.0056				2.72			
CFD 4	.75		2.80		.13		1.5003		1 1/2-12		8.97			
CCFD 4	19.1		71.0		3.2		38.108 +.0002/-0.0003 +.0005/-0.0060				4.07			
CFD 5	.875		3.56		.13		2.0003		2-12		18.37			
CCFD 5	22.2		90.5		3.2		50.808 +.0002/-0.0003 +.0005/-0.0064				8.33			
CFD 6	1.00		4.47		.13		2.5003		2 1/2-12		31.99			
CCFD 6	25.4		113.5		3.2		63.508 +.0002/-0.0003 +.0005/-0.0068				14.51			

Clamping torque is based on dry threads. If threads are lubricated, use half of value shown.

# MCGILL® Heavy Duty CAMROL Bearings



**Basic Construction Type:** Yoke Type Crowned / Cylindrical Outside Diameter

**Rolling Elements:** Full Complement Cylindrical Roller

**Bearing Material:** Bearing Quality Steel

**Seal Type:** Rubber Lip Seal

**Lubrication:** Lithium Soap Grease NLGI #2

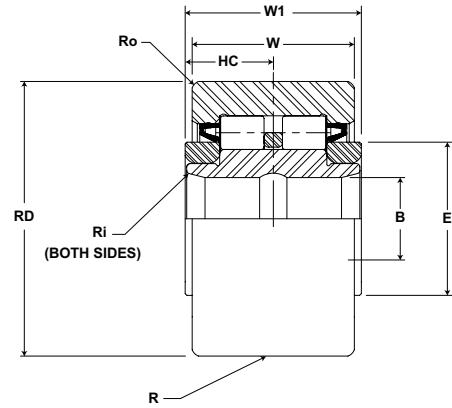

## CYRD

Part No.	RD		W		B		W1		R	Track Roller Dynamic Rating	Track Roller Static Rating
	Roller Diameter		Roller Width		Bore Diameter		Overall Width		Crown		
	inch mm		inch mm		inch mm		inch mm		Prefix CCYRD-XX		
	Nom.	Tol.	Nom.	Tol.	Nom.	Tol.	Nom.	Tol.	Radius		
CYRD 1 1/4	1.250	+0/-0.001	.750	+0/-0.001	.375	+0.002/-0.0004	.8125	+0.005/-0.01	Cylindrical	3,300 14,680	2,400 10,680
CCYRD 1 1/4	31.75	+0/-0.03	9.05	+0/-0.03	9.53	+0.0005/-0.0010	20.6	+0.13/-0.25	14 356		
CYRD 1 3/8	1.375	+0/-0.001	.750	+0/-0.001	.375	+0.002/-0.0004	.8125	+0.005/-0.01	Cylindrical	3,600 16,000	2,400 10,680
CCYRD 1 3/8	34.93	+0/-0.03	9.05	+0/-0.05	9.53	+0.0005/-0.0010	20.6	+0.13/-0.25	14 356		
CYRD 1 1/2	1.500	+0/-0.001	.875	+0/-0.001	.438	+0.002/-0.0004	.9375	+0.005/-0.01	Cylindrical	5,000 22,240	4,100 18,240
CCYRD 1 1/2	38.10	+0/-0.03	2.23	+0/-0.07	1.11	+0.0005/-0.0010	23.8	+0.13/-0.25	20 508		
CYRD 1 5/8	1.625	+0/-0.001	.875	+0/-0.001	.438	+0.002/-0.0004	.9375	+0.005/-0.01	Cylindrical	5,400 24,020	4,100 18,240
CCYRD 1 5/8	41.28	+0/-0.03	2.23	+0/-0.09	1.11	+0.0005/-0.0010	23.8	+0.13/-0.25	20 508		
CYRD 1 3/4	1.750	+0/-0.001	1.000	+0/-0.001	.500	+0.002/-0.0004	1.0625	+0.005/-0.01	Cylindrical	6,650 29,580	6,100 27,130
CCYRD 1 3/4	44.45	+0/-0.03	25.40	+0/-0.11	2.70	+0.0005/-0.0010	27.0	+0.13/-0.25	20 508		
CYRD 1 7/8	1.875	+0/-0.001	1.000	+0/-0.001	.500	+0.002/-0.0004	1.0625	+0.005/-0.01	Cylindrical	7,100 31,580	6,100 27,130
CCYRD 1 7/8	47.63	+0/-0.03	25.40	+0/-0.13	2.70	+0.0005/-0.0010	27.0	+0.13/-0.25	20 508		
CYRD 2	2.000	+0/-0.001	1.250	+0/-0.001	.625	+0.002/-0.0004	1.3125	+0.005/-0.01	Cylindrical	9,500 42,260	8,300 36,920
CCYRD 2	50.80	+0/-0.03	31.75	+0/-0.15	5.88	+0.0005/-0.0010	33.3	+0.13/-0.25	24 610		
CYRD 2 1/4	2.250	+0/-0.001	1.250	+0/-0.001	.625	+0.002/-0.0004	1.3125	+0.005/-0.01	Cylindrical	10,500 46,700	8,300 36,920
CCYRD 2 1/4	57.15	+0/-0.03	31.75	+0/-0.17	5.88	+0.0005/-0.0010	33.3	+0.13/-0.25	24 610		

Metric dimensions for reference only.

Not all parts are available from stock. Please contact customer service for availability (800) 626-2120.

For more information on bearing capabilities outside of our standard offering, please contact Application Engineering (800) 626-2093.

# Heavy Duty CAMROL Bearings **McGILL**



## CYRD

Part No.	HC	E	Ri	Ro	Recommended Shaft Diameters						WT
	Hole Center	Min. Clamping Diameter	Outer Corner Radius	Inner Corner Radius	Push Fit		Drive Fit		Press Fit		Bearing Weight
	inch mm	inch mm	inch mm	inch mm	inch mm		inch mm		inch mm		lb kg
	(Ref)	(Ref)	(Ref)	(Ref)	Nom	Tol	Nom	Tol	Nom	Tol	kg
CYRD 1 1/4	.31 7.9	.98 5.0	.03 0.8	.03 0.8	.3745 9.512	±.0002 ±.005	.3751 9.53	±.0002 ±.005	.3753 9.53	±.0002 ±.005	.21 .09
CCYRD 1 1/4											
CYRD 1 3/8	.31 7.9	.98 5.0	.03 0.8	.05 1.2	.3745 9.512	±.0002 ±.005	.3751 9.53	±.0002 ±.005	.3753 9.53	±.0002 ±.005	.26 .12
CCYRD 1 3/8											
CYRD 1 1/2	.38 9.5	1.09 27.8	.04 1.0	.06 1.6	.4370 1.100	±.0002 ±.005	.4376 11.12	±.0002 ±.005	.4378 11.12	±.0002 ±.005	.35 .16
CCYRD 1 1/2											
CYRD 1 5/8	.38 9.5	1.09 27.8	.04 1.0	.06 1.6	.4370 1.100	±.0002 ±.005	.4376 11.12	±.0002 ±.005	.4378 11.12	±.0002 ±.005	.43 .19
CCYRD 1 5/8											
CYRD 1 3/4	.44 1.1	1.25 31.8	.05 1.3	.06 1.6	.4995 2.687	±.0002 ±.005	.5001 12.70	±.0002 ±.005	.5005 12.71	±.0002 ±.005	.57 .26
CCYRD 1 3/4											
CYRD 1 7/8	.44 1.1	1.25 31.8	.05 1.3	.06 1.6	.4995 2.687	±.0002 ±.005	.5001 12.70	±.0002 ±.005	.5005 12.71	±.0002 ±.005	.66 .29
CCYRD 1 7/8											
CYRD 2	.50 2.7	1.41 35.7	.06 1.5	.09 2.4	.6245 5.862	±.0002 ±.005	.6251 15.88	±.0002 ±.005	.6255 15.89	±.0002 ±.005	.88 .39
CCYRD 2											
CYRD 2 1/4	.50 2.7	1.41 35.7	.06 1.5	.09 2.4	.6245 5.862	±.0002 ±.005	.6251 15.88	±.0002 ±.005	.6255 15.89	±.0002 ±.005	1.18 .54
CCYRD 2 1/4											

# MCGILL® Heavy Duty CAMROL Bearings



**Basic Construction Type:** Yoke Type Crowned / Cylindrical Outside Diameter

**Rolling Elements:** Full Complement Cylindrical Roller

**Bearing Material:** Bearing Quality Steel

**Seal Type:** Rubber Lip Seal

**Lubrication:** Lithium Soap Grease NLGI #2

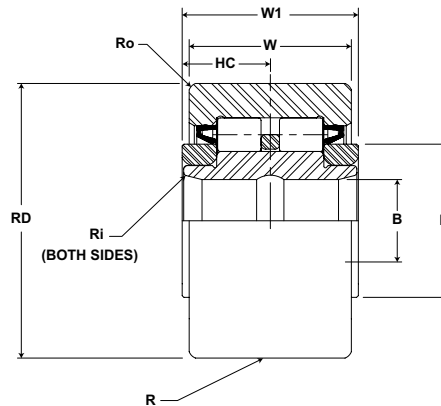

## CYRD

Part No.	RD		W		B		W1		R	Track Roller Dynamic Rating	Track Roller Static Rating
	Roller Diameter		Roller Width		Bore Diameter		Overall Width		Crown		
	inch mm	inch mm	inch mm	inch mm	inch mm	inch mm	inch mm	inch mm	Prefix CCYRD-XX	lb/N	lb/N
CYRD 2 1/2	2.500	+0/-0.001	1.500	+0/-0.001	.750	+0.002/-0.0004	1.5625	+0.005/-0.01	Cylindrical	14,000 62,270	10,400 46,260
CCYRD 2 1/2	63.50	+0/-0.03	38.10	+0/-0.19	9.05	+0.0005/-0.0010	39.7	+0.13/-0.25	30 762		
CYRD 2 3/4	2.750	+0/-0.001	1.500	+0/-0.001	.750	+0.002/-0.0004	1.5625	+0.005/-0.01	Cylindrical	15,000 66,720	10,400 46,260
CCYRD 2 3/4	69.85	+0/-0.03	38.10	+0/-0.21	9.05	+0.0005/-0.0010	39.7	+0.13/-0.25	30 762		
CYRD 3	3.000	+0/-0.001	1.750	+0/-0.001	1.000	+0.001/-0.0005	1.8125	+0.005/-0.01	Cylindrical	18,300 81,400	18,100 80,510
CCYRD 3	76.20	+0/-0.03	44.45	+0/-0.23	25.40	+0.0003/-0.0013	46.0	+0.13/-0.25	30 762		
CYRD 3 1/4	3.250	+0/-0.001	1.750	+0/-0.001	1.000	+0.001/-0.0005	1.8125	+0.005/-0.01	Cylindrical	20,300 90,290	18,100 80,510
CCYRD 3 1/4	82.55	+0/-0.03	44.45	+0/-0.25	25.40	+0.0003/-0.0013	46.0	+0.13/-0.25	30 762		
CYRD 3 1/2	3.500	+0/-0.001	2.000	+0/-0.001	1.125	+0.001/-0.0005	2.0625	+0.005/-0.01	Cylindrical	23,700 105,420	21,500 95,630
CCYRD 3 1/2	88.90	+0/-0.03	50.80	+0/-0.27	28.58	+0.0003/-0.0013	52.4	+0.13/-0.25	30 762		
CYRD 4	4.000	+0/-0.001	2.250	+0/-0.001	1.250	+0.001/-0.0005	2.3125	+0.005/-0.01	Cylindrical	32,500 144,560	22,800 101,410
CCYRD 4	101.60	+0/-0.03	57.15	+0/-0.29	31.75	+0.0003/-0.0013	58.7	+0.13/-0.25	30 762		
CYRD 5	5.000	+0/-0.001	2.750	+0/-0.001	1.750	+0.001/-0.0005	2.875	+0.005/-0.01	Cylindrical	50,500 224,620	50,800 225,960
CCYRD 5	127.00	+0/-0.03	69.85	+0/-0.31	44.45	+0.0003/-0.0013	73.0	+0.13/-0.25	48 1,219		
CYRD 6	6.000	+0/-0.001	3.250	+0/-0.001	2.250	+0.001/-0.0005	3.375	+0.005/-0.01	Cylindrical	71,500 318,030	86,100 382,970
CCYRD 6	152.40	+0/-0.03	82.55	+0/-0.33	57.15	+0.0003/-0.0013	85.7	+0.13/-0.25	56 1,422		

Metric dimensions for reference only.

Not all parts are available from stock. Please contact customer service for availability (800) 626-2120.

For more information on bearing capabilities outside of our standard offering, please contact Application Engineering (800) 626-2093.

# Heavy Duty CAMROL Bearings **McGILL**



## CYRD

Part No.	HC	E	Ri	Ro	Recommended Shaft Diameters						WT
	Hole Center	Min. Clamping Diameter	Outer Corner Radius	Inner Corner Radius	Push Fit		Drive Fit		Press Fit		Bearing Weight
	inch mm	inch mm	inch mm	inch mm	inch mm		inch mm		inch mm		lb kg
	(Ref)	(Ref)	(Ref)	(Ref)	Nom	Tol	Nom	Tol	Nom	Tol	
CYRD 2 1/2	.56 4.3	1.69 42.9	.07 1.8	.09 2.4	.7495 9.037	±.0002 ±.005	.7501 19.05	±.0002 ±.005	.7505 19.06	±.0002 ±.005	1.74 .79
CCYRD 2 1/2											
CYRD 2 3/4	.56 4.3	1.69 42.9	.07 1.8	.09 2.4	.7495 9.037	±.0002 ±.005	.7501 19.05	±.0002 ±.005	.7505 19.06	±.0002 ±.005	2.17 .98
CCYRD 2 3/4											
CYRD 3	.63 5.9	2.13 54.0	.08 2.0	.13 3.2	.9994 5.385	±.0002 ±.005	1.002 25.5	±.0002 ±.005	1.006 25.55	±.0002 ±.005	3.08 1.39
CCYRD 3											
CYRD 3 1/4	.63 5.9	2.13 54.0	.08 2.0	.13 3.2	.9994 5.385	±.0002 ±.005	1.002 25.5	±.0002 ±.005	1.006 25.55	±.0002 ±.005	3.62 1.64
CCYRD 3 1/4											
CYRD 3 1/2	.69 7.5	2.44 61.9	.09 2.3	.13 3.2	1.1244 28.560	±.0002 ±.005	1.1252 28.58	±.0002 ±.005	1.1256 28.59	±.0002 ±.005	4.41 2.00
CCYRD 3 1/2											
CYRD 4	.75 9.1	2.80 71.0	.10 2.5	.13 3.2	1.2494 31.735	±.0002 ±.005	1.2502 31.76	±.0002 ±.005	1.2506 31.77	±.0002 ±.005	6.57 2.98
CCYRD 4											
CYRD 5	.88 2.2	3.56 90.5	.11 2.8	.13 3.2	1.7494 44.435	±.0002 ±.005	1.7502 44.46	±.0002 ±.005	1.7506 44.47	±.0002 ±.005	12.33 5.59
CCYRD 5											
CYRD 6	1.00 25.4	4.47 113.5	.12 3.0	.13 3.2	2.2494 57.135	±.0002 ±.005	2.2502 57.16	±.0002 ±.005	2.2506 57.17	±.0002 ±.005	20.47 9.29
CCYRD 6											

# MCGILL® Heavy Duty CAMROL Bearings



- Basic Construction Type:** Stud Type Crowned / Cylindrical Outside Diameter
- Rolling Elements:** Full Complement Cylindrical Roller
- Bearing Material:** Bearing Quality Steel
- Seal Type:** Metallic Shield
- Lubrication:** Lithium Soap Grease NLGI #2
- System Configuration:** Concentric / Eccentric
- Mounting Feature:** Slot / Hex Hole

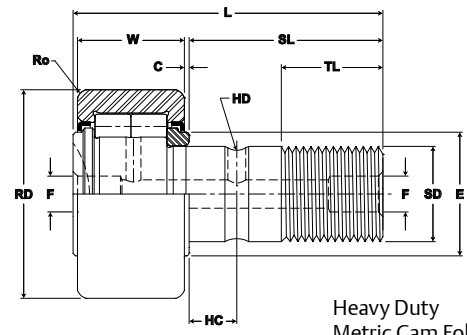

Heavy Duty Metric Cam Follower

## MCFD, MCFDE

Part No.	RD		W		SD		SL	C	TL	L	R	ECC	G	BD	Track Roller Dynamic Rating	Track Roller Static Rating
With Shields	Roller Diameter		Roller Width		Stud Diameter		Stud Length	Endplate Extension	Minimum Thread Length	Length Overall	Cylindrical	Eccentric				
	mm inch	mm inch	mm inch	mm inch	mm inch	mm inch	mm inch	mm inch	mm inch	Suffix MCFD-xx-X	Base Modifier MCFDE-xx					
Nom.	Tol.	Nom.	Tol.	Nom.	Tol.	(Ref)	(Ref)	(Ref)	(Ref)	(Ref)	(Ref)	(Ref)	mm inch	See Table	N/lb	N/lb
MCFD 35	35.000 1.3780	+0/-.050 +0/-.002	18.00 .709	+0/.12 +0/-0.005	16.000 .6299	+0/-.018 +0/-0.0007	32.50 1.280	.80 .031	17.00 .669	52.00 2.047	500 20	N/A	N/A	N/A	16,000 3,597	18,000 4,047
MCFDE 35		14 .02		20 .79												
MCFD 35 X		N/A		N/A		N/A										
MCFDE 35 X		14 .02		20 .79												
MCFD 40	40.000 1.5748	+0/-.050 +0/-.002	20.00 .787	+0/.12 +0/-0.009	18.000 .7087	+0/-.018 +0/-0.0007	36.50 1.437	.80 .031	19.00 .748	58.00 2.283	500 20	N/A	N/A	N/A	18,000 4,047	22,000 4,946
MCFDE 40		16 .04		22 .87												
MCFD 40 X		N/A		N/A		N/A										
MCFDE 40 X		16 .04		22 .87												
MCFD 47	47.000 1.8504	+0/-.050 +0/-.002	24.00 .945	+0/.12 +0/-0.013	20.000 .7874	+0/-.021 +0/-0.0008	40.50 1.594	.80 .031	21.00 .827	66.00 2.598	500 20	N/A	N/A	N/A	27,000 6,070	32,000 7,194
MCFDE 47		18 .04		24 .94												
MCFD 47 X		N/A		N/A		N/A										
MCFDE 47 X		18 .04		24 .94												
MCFD 52	52.000 2.0472	+0/-.050 +0/-.002	24.00 .945	+0/.12 +0/-0.017	20.000 .7874	+0/-.021 +0/-0.0008	40.50 1.594	.80 .031	21.00 .827	66.00 2.598	500 20	N/A	N/A	N/A	30,000 6,745	35,000 7,869
MCFDE 52		18 .04		24 .94												
MCFD 52 X		N/A		N/A		N/A										
MCFDE 52 X		18 .04		24 .94												
MCFD 62	62.000 2.4409	+0/-.050 +0/-.002	29.00 1.142	+0/.12 +0/-0.021	24.000 .9449	+0/-.021 +0/-0.0008	49.50 1.949	.80 .031	25.00 .984	80.00 3.150	500 20	N/A	N/A	N/A	41,000 9,218	48,000 10,791
MCFDE 62		22 .04		28 .10												
MCFD 62 X		N/A		N/A		N/A										
MCFDE 62 X		22 .04		28 .10												

1. Standard bearing has a crowned roller outside diameter. For straight cylindrical outside roller diameter, add suffix "X". Example - MCFD-35-X.  
 2. Since load, lubrication method, temperature and other factors affect the maximum operating speed, it is impossible to determine precise limiting speed. The listed limiting speeds are based on lightly loaded bearings having adequate lubrication and are listed only as a design guide. If grease lubricated, frequent relubrication is required. Actual bearing testing in the specific application should be conducted if the anticipated operating speed approaches the listed limiting speed.  
 3. Clamping torque is based on dry threads. If threads are lubricated, use half of value shown.

Inch dimensions for reference only.  
 Not all parts are available from stock. Please contact customer service for availability (800) 626-2120.  
 For more information on bearing capabilities outside of our standard offering, please contact Application Engineering (800) 626-2093.

# Heavy Duty CAMROL Bearings **MCGILL**

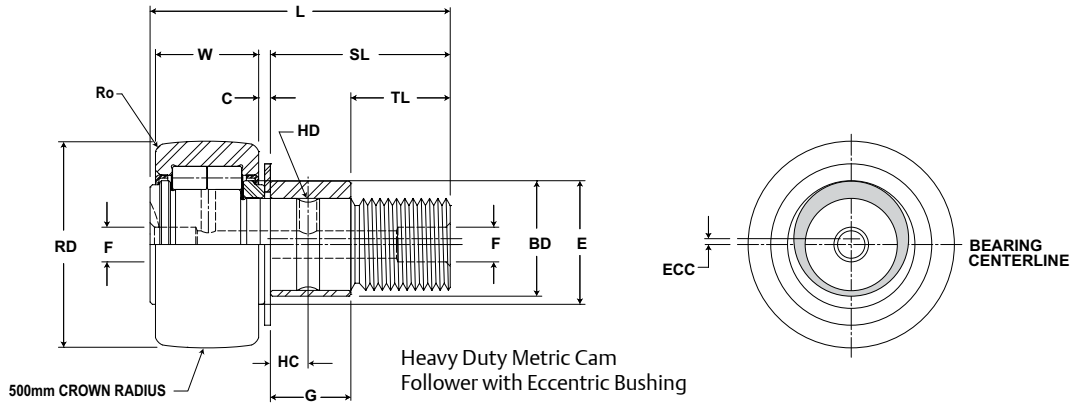

## MCFD, MCFDE

Part No.	HC	HD	D	E	Ro	HBD	sdt	Thread Type	CT	LSD	WT
With Shields	Hole Center	Radial Lub. Hole Diameter	Lub. Hole Dia. / Lub. Fitting	Min. Clamping Diameter	Outer Radius (suffix X)	Housing Bore Diameter		Thread Type	Clamping Torque	Limiting Speed (Grease)	Bearing Weight
	mm inch		mm inch		mm inch		Nm in-lb		RPM	kg lb	
	(Ref)	(Ref)	(Ref)	(Ref)	(Ref)	Nom.					Tol.
MCFD 35	8.00 .315	3.00 .118	6.00 .236	21.00 .827	1.00 .039	16.000 .6299	+0/--.018 +0/--.0007	M16x1.5	85 752	6,500	.16 .36
MCFDE 35											
MCFD 35 X											
MCFDE 35 X											
MCFD 40	8.00 .315	3.00 .118	6.00 .236	23.00 .906	1.50 .059	18.000 .7087	+0/--.018 +0/--.0007	M18x1.5	85 752	5,500	.24 .53
MCFDE 40											
MCFD 40 X											
MCFDE 40 X											
MCFD 47	9.00 .354	4.00 .157	8.00 .315	27.00 1.063	1.50 .059	20.000 .7874	+0/--.021 +0/--.0008	M20x1.5	118 1,044	4,200	.38 .84
MCFDE 47											
MCFD 47 X											
MCFDE 47 X											
MCFD 52	9.00 .354	4.00 .157	8.00 .315	21.00 .827	1.50 .059	20.000 .7874	+0/--.021 +0/--.0008	M20x1.5	118 1,044	3,400	.45 .99
MCFDE 52											
MCFD 52 X											
MCFDE 52 X											
MCFD 62	11.00 .433	4.00 .157	8.00 .315	38.00 1.496	2.00 .079	24.000 .9449	+0/--.021 +0/--.0008	M24x1.5	216 1,912	2,600	.80 1.75
MCFDE 62											
MCFD 62 X											
MCFDE 62 X											



# MCGILL® Heavy Duty CAMROL Bearings



- Basic Construction Type:** Stud Type Crowned / Cylindrical Outside Diameter
- Rolling Elements:** Full Complement Cylindrical Roller
- Bearing Material:** Bearing Quality Steel
- Seal Type:** Metallic Shield
- Lubrication:** Lithium Soap Grease NLGI #2
- System Configuration:** Concentric / Eccentric / Heavy Stud
- Mounting Feature:** Slot / Hex Hole
- Dimensional Interchange:** ISO Standard

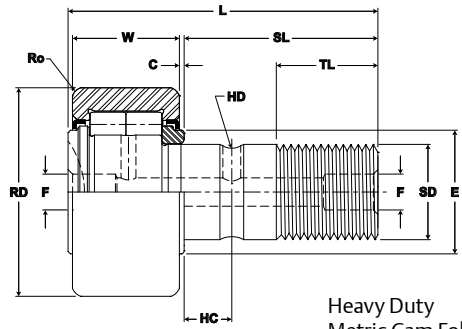

Heavy Duty Metric Cam Follower

## MCFD, MCFDE

Part No.	RD		W		SD		SL	C	TL	L	R	ECC	G	BD	Track Roller Dynamic Rating	Track Roller Static Rating	
With Shields	Roller Diameter		Roller Width		Stud Diameter		Stud Length	Endplate Extension	Minimum Thread Length	Length Overall	Cylindrical Suffix MCFD-xx-X	Eccentric Base Modifier MCFDE-xx					
	mm inch	mm inch	mm inch	mm inch	mm inch	mm inch	mm inch	mm inch	mm inch	mm inch	mm inch	mm inch	mm inch				
Nom.	Tol.	Nom.	Tol.	Nom.	Tol.	(Ref)	(Ref)	(Ref)	(Ref)	(Ref)	(Ref)	(Ref)	(Ref)	(Ref)	N/lb	N/lb	
MCFD 72	72.000 2.8346	+0/- .050 +0/- .002	29.00 1.142	+0/.12 +0/- .025	24.000 .9449	+0/- .021 +0/- .0008	49.50 1.949	.80 .031	25.00 .984	80.00 3.150	500 20	Cylindrical	N/A	N/A	N/A	46,000 10,342	57,000 12,815
MCFDE 72		1 .04											22 0.87	28 .10			
MCFD 72 X		N/A											N/A	N/A			
MCFDE 72 X		1 .04											22 0.87	28 .10			
MCFD 80	80.000 3.1496	+0/- .050 +0/- .002	35.00 1.378	+0/.12 +0/- .029	30.000 1.1811	+0/- .021 +0/- .0008	63.00 2.480	1.00 .039	32.00 1.260	100.00 3.937	500 20	Cylindrical	N/A	N/A	N/A	67,000 15,063	91,000 20,459
MCFDE 80		1.5 .06											29 1.14	35 .38			
MCFD 80 X		N/A											N/A	N/A			
MCFDE 80 X		1.5 .06											29 1.14	35 .38			
MCFD 90	90.000 3.5433	+0/- .050 +0/- .002	35.00 1.378	+0/.12 +0/- .033	30.000 1.1811	+0/- .021 +0/- .0008	63.00 2.480	1.00 .039	32.00 1.260	100.00 3.937	500 20	Cylindrical	N/A	N/A	N/A	67,000 15,063	101,000 22,707
MCFDE 90		1.5 .06											29 1.14	35 .38			
MCFD 90 X		N/A											N/A	N/A			
MCFDE 90 X		1.5 .06											29 1.14	35 .38			

1. Standard bearing has a crowned roller outside diameter. For straight cylindrical outside roller diameter, add suffix "X". Example - MCFD-35-X.  
 2. Since load, lubrication method, temperature and other factors affect the maximum operating speed, it is impossible to determine precise limiting speed. The listed limiting speeds are based on lightly loaded bearings having adequate lubrication and are listed only as a design guide. If grease lubricated, frequent relubrication is required. Actual bearing testing in the specific application should be conducted if the anticipated operating speed approaches the listed limiting speed.  
 3. Clamping torque is based on dry threads. If threads are lubricated, use half of value shown.

Metric dimensions for reference only.  
 Not all parts are available from stock. Please contact customer service for availability (800) 626-2120.  
 For more information on bearing capabilities outside of our standard offering, please contact Application Engineering (800) 626-2093.

# Heavy Duty CAMROL Bearings **MCGILL**

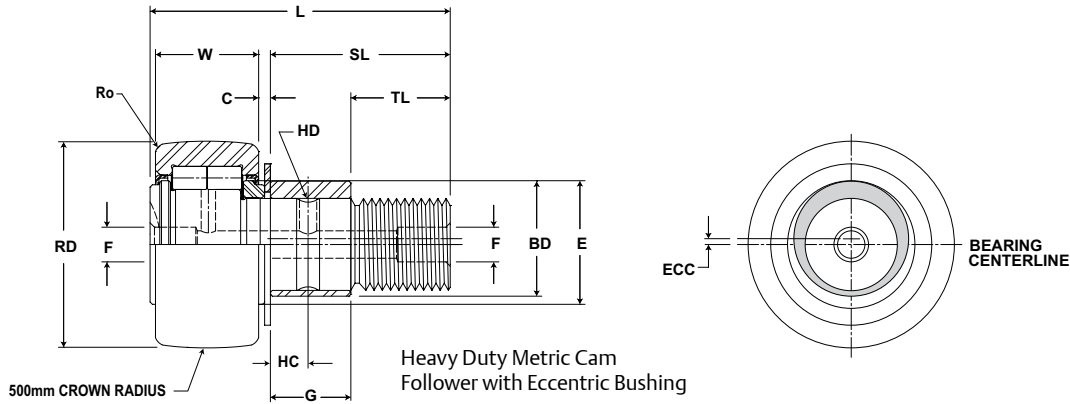

## MCFD, MCFDE

Part No.	HC	HD	D	E	Ro	HBD	sdt	Thread Type	CT	LSD	WT
With Shields	Hole Center	Radial Lub. Hole Diameter	Lub. Hole Dia. / Lub. Fitting	Min. Clamping Diameter	Outer Radius (suffix X)	Housing Bore Diameter		Thread Type	Clamping Torque	Limiting Speed (Grease)	Bearing Weight
	mm inch		mm inch		mm inch		Nm in-lb		RPM	kg lb	
	(Ref)	(Ref)	(Ref)	(Ref)	(Ref)	Nom.					Tol.
MCFD 72	12.00 .472	4.00 .157	8.00 .315	44.00 1.732	2.00 .079	24.000 .9449	+0/- .021 +0/- .0008	M24x1.5	216 1,912	2,100	1.01 2.23
MCFDE 72											
MCFD 72 X											
MCFDE 72 X											
MCFD 80	15.00 .591	4.00 .157	8.00 .315	47.00 1.850	2.00 .079	30.000 1.1811	+0/- .021 +0/- .0008	M30x1.5	441 3,903	1,800	1.54 3.39
MCFDE 80											
MCFD 80 X											
MCFDE 80 X											
MCFD 90	15.00 .591	4.00 .157	8.00 .315	47.00 1.850	2.00 .079	30.000 1.1811	+0/- .021 +0/- .0008	M30x1.5	441 3,903	1,800	1.96 4.32
MCFDE 90											
MCFD 90 X											
MCFDE 90 X											

# MCGILL® Heavy Duty CAMROL Bearings



**Basic Construction Type:** Yoke Type Crowned / Cylindrical Outside Diameter

**Rolling Elements:** Full Complement Cylindrical Roller

**Bearing Material:** Bearing Quality Steel

**Seal Type:** Metallic Shield

**Lubrication:** Lithium Soap Grease NLGI #2

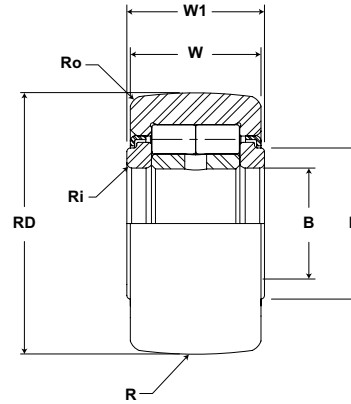

## MCYRD

Part No.	RD		W		B		W1		R	Track Roller Dynamic Rating	Track Roller Static Rating
	Roller Diameter		Roller Width		Bore Diameter		Overall Width		Cylindrical		
	mm inch		mm inch		mm inch		mm inch		Suffix MCF-X		
	Nom.	Tol.	Nom.	Tol.	Nom	Tol	Nom	Tol	mm inch Radius		
MCYRD 15	35.000	+0/- .050 +0/- .002	18.00	+0/.12 +0/- .005	15.000	+0/- .008 +0/- .0003	19.00	+0/-0.21 +0/-0.0008	500 20	16,000	18,000
MCYRD 15 X	1.3780	+0/-0.011 +0/- 0.0004	.709		.5906		.748		Cylindrical	3,597	4,047
MCYRD 17	40.000	+0/- .050 +0/- .002	20.00	+0/.12 +0/- .009	17.000	+0/- .008 +0/- .0003	21.00	+0/-0.21 +0/-0.0008	500 20	18,000	22,000
MCYRD 17 X	1.5748	+0/-0.011 +0/- 0.0004	.787		.6693		.827		Cylindrical	4,047	4,946
MCYRD 20	47.000	+0/- .050 +0/- .002	24.00	+0/.12 +0/- .013	20.000	+0/- .010 +0/- .0004	25.00	+0/-0.21 +0/-0.0008	500 20	27,000	32,000
MCYRD 20 X	1.8504	+0/-0.011 +0/- 0.0004	.945		.7874		.984		Cylindrical	6,070	7,194
MCYRD 25	52.000	+0/- .050 +0/- .002	24.00	+0/.12 +0/- .017	25.000	+0/- .010 +0/- .0004	25.00	+0/-0.21 +0/-0.0008	500 20	30,000	35,000
MCYRD 25 X	2.0472	+0/-0.013 +0/- 0.0005	.945		.9843		.984		Cylindrical	6,745	7,869
MCYRD 30	62.000	+0/- .050 +0/- .002	28.00	+0/.12 +0/- .021	30.000	+0/- .010 +0/- .0004	29.00	+0/-0.21 +0/-0.0008	500 20	41,000	47,000
MCYRD 30 X	2.4409	+0/-0.013 +0/- 0.0005	1.102		1.1811		1.142		Cylindrical	9,218	10,567
MCYRD 35	72.000	+0/- .050 +0/- .002	28.00	+0/.12 +0/- .025	35.000	+0/- .012 +0/- .0005	29.00	+0/-0.21 +0/-0.0008	500 20	46,000	57,000
MCYRD 35 X	2.8346	+0/-0.013 +0/- 0.0005	1.102		1.3780		1.142		Cylindrical	10,342	12,815
MCYRD 40	80.000	+0/- .050 +0/- .002	30.00	+0/.12 +0/- .029	40.000	+0/- .012 +0/- .0005	32.00	+0/-0.25 +0/-0.009	500 20	64,000	71,000
MCYRD 40 X	3.1496	+0/-0.015 +0/- 0.0006	1.181		1.5748		1.260		Cylindrical	14,388	15,962
MCYRD 45	85.000	+0/- .050 +0/- .002	30.00	+0/.12 +0/- .033	45.000	+0/- .012 +0/- .0005	32.00	+0/-0.25 +0/-0.009	500 20	67,000	72,000
MCYRD 45 X	3.3465	+0/-0.015 +0/- 0.0006	1.181		1.7717		1.260		Cylindrical	15,063	16,187
MCYRD 50	90.000	+0/- .050 +0/- .002	30.00	+0/.12 +0/- .037	50.000	+0/- .012 +0/- .0005	32.00	+0/-0.25 +0/-0.009	500 20	71,000	77,000
MCYRD 50 X	3.5433	+0/-0.015 +0/- 0.0006	1.181		1.9685		1.260		Cylindrical	15,962	17,311

1. Standard bearing has a crowned roller outside diameter. For straight cylindrical outside roller diameter, add suffix "X". Example - MCYRD-15-X.

2. Since load, lubrication method, temperature and other factors affect the maximum operating speed, it is impossible to determine precise limiting speed. The listed limiting speeds are based on lightly loaded bearings having adequate lubrication and are listed only as a design guide. If grease lubricated, frequent re-lubrication is required. Actual bearing testing in the specific application should be conducted if the anticipated operating speed approaches the listed limiting speed.

3. Positive clamping across endplates required to ensure proper end play after mounting.

Metric dimensions for reference only.  
 Not all parts are available from stock. Please contact customer service for availability (800) 626-2120.  
 For more information on bearing capabilities outside of our standard offering, please contact Application Engineering (800) 626-2093.



## MCYRD

E	Ro	Ri	LF	LFT	TF	TFT	LSD	WT
	Outer Corner Radius	Inner Corner Radius	Recommended Shaft Diameters				Limiting Speed (Grease)	Bearing Weight
			Loose Fit		Light Fit			
	mm inch	mm inch	mm inch		mm inch		RPM	kg lb
(Ref)	(Ref)	Nom	Tol	Nom	Tol			
20.00 .787	.60 .024	.30 .012	14.994 .5903	+0/-.011 +0/-.0004	15.000 .5906	+0/-.011 +0/-.0004	6,500	.10 .22
22.00 .866	1.00 .039	.30 .012	16.994 .6691	+0/-.011 +0/-.0004	17.000 .6693	+0/-.011 +0/-.0004	5,500	.15 .32
27.00 1.063	1.00 .039	.30 .012	19.993 .7871	+0/-.013 +0/-.0005	20.000 .7874	+0/-.013 +0/-.0005	4,200	.25 .54
31.00 1.220	1.00 .039	.30 .012	24.993 .9840	+0/-.013 +0/-.0005	25.000 .9843	+0/-.013 +0/-.0005	3,400	.28 .62
38.00 1.496	1.00 .039	.30 .012	29.993 1.1808	+0/-.013 +0/-.0005	30.000 1.1811	+0/-.013 +0/-.0005	2,600	.46 1.02
44.00 1.732	1.10 .043	.60 .024	34.991 1.3776	+0/-.016 +0/-.0006	35.000 1.3780	+0/-.016 +0/-.0006	2,100	.63 1.39
51.00 2.008	1.10 .043	.60 .024	39.991 1.5744	+0/-.016 +0/-.0006	40.000 1.5748	+0/-.016 +0/-.0006	1,600	.82 1.80
55.00 2.165	1.10 .043	.60 .024	44.991 1.7713	+0/-.016 +0/-.0006	45.000 1.7717	+0/-.016 +0/-.0006	1,400	.89 1.95
60.00 2.362	1.10 .043	.60 .024	45.991 1.8107	+0/-.016 +0/-.0006	50.000 1.9685	+0/-.016 +0/-.0006	1,300	.95 2.09

## McGill Special Duty Cam Followers

Special-Duty CAMROL bearings are available feature black oxide treated bearing steel in both inch and metric sizes for your motion control needs. Designed for severe applications, bearings thick section outer race, together with a caged (retainer) needle roller set provides the basic foundation for a cam follower suited for severe duty. Integral flange construction, on stud version bearings help maintain bearing integrity throughout the service life. A metallic face plug seal provides a wear resistant seal while the heavy duty seal provides a barrier for contaminate entry to support reduced maintenance applications. Within the following section you can learn more about these feature and how the can be applied to your tough application.

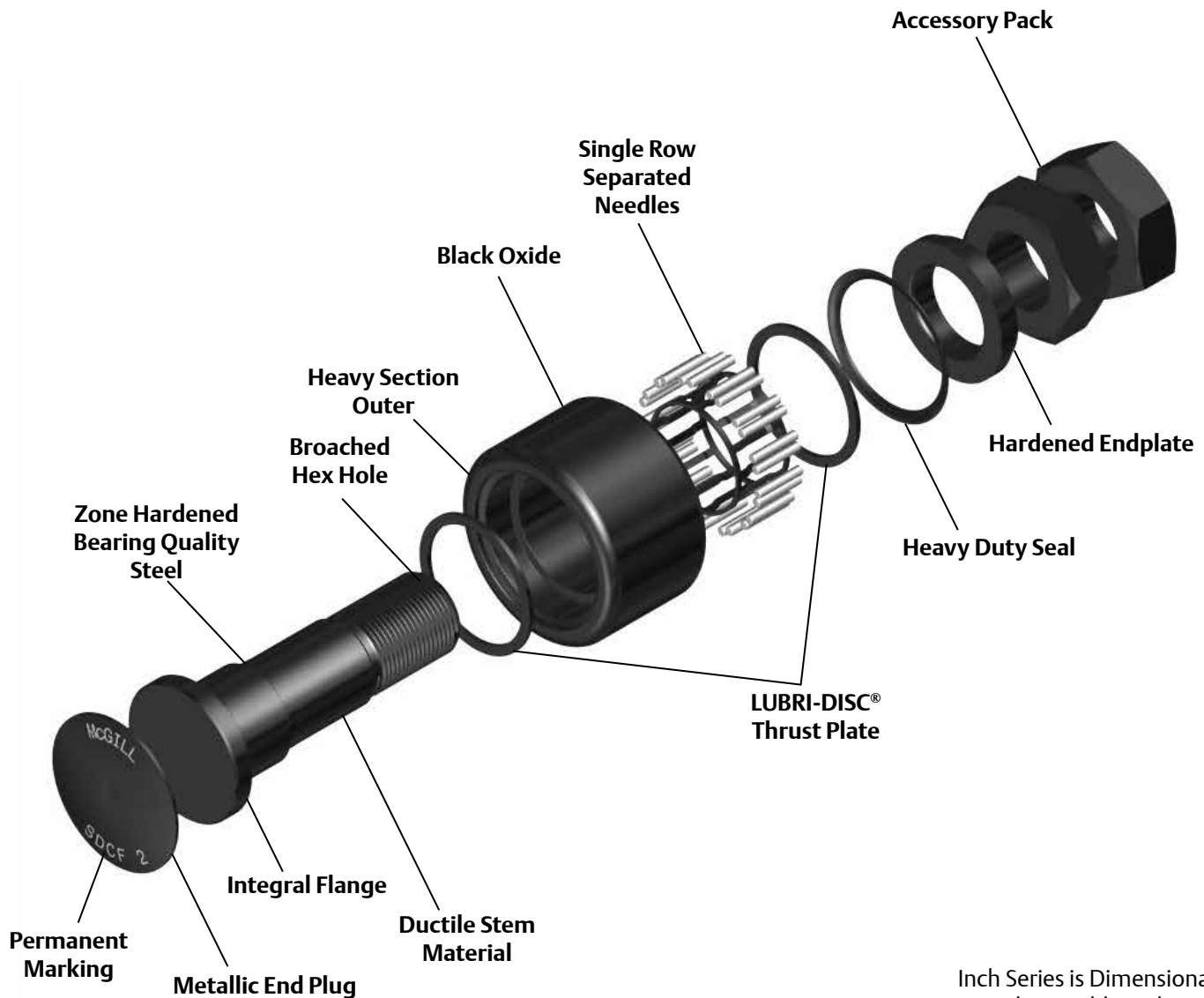

Inch Series is Dimensionally Interchangeable with Standard INCH CAMROL Factory Filled Synthetic Grease.

# Special Duty Cam Follower Nomenclature

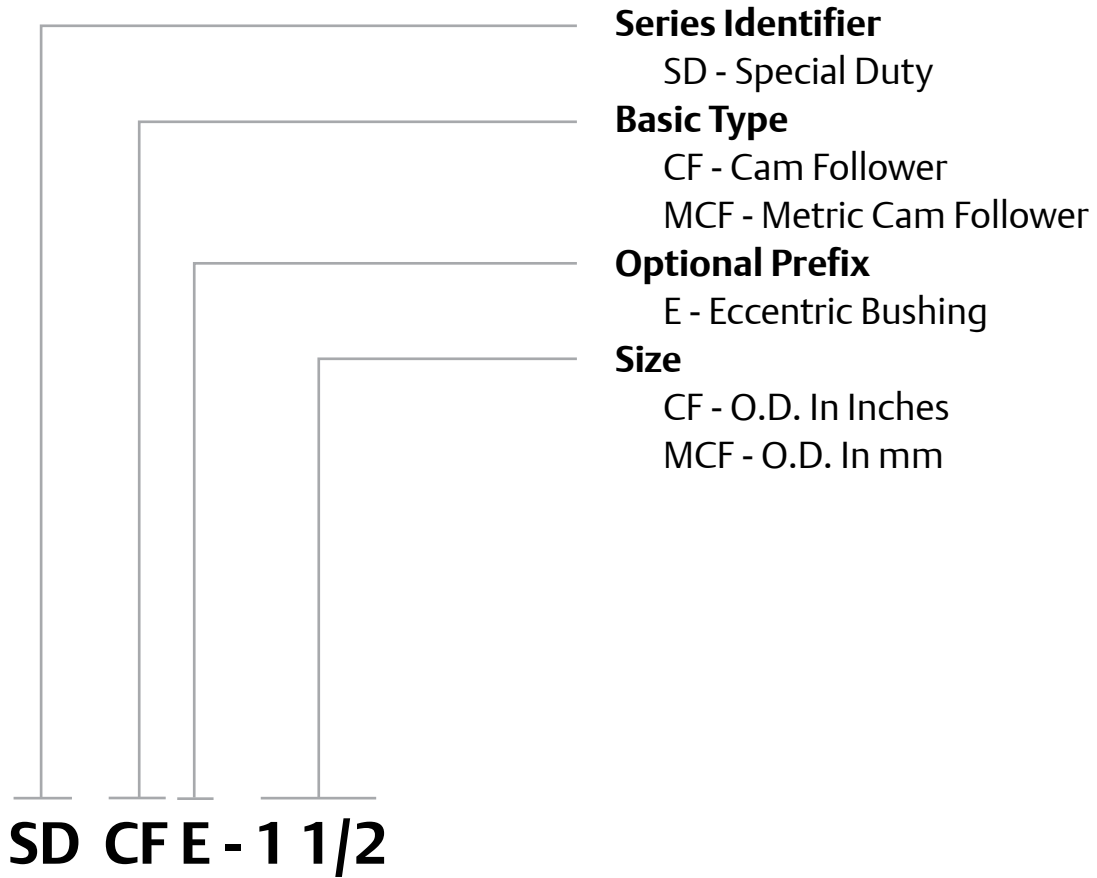

## Features and Benefits



### Retainer Type

The retainer (cage) option provides heat-treated steel cage for improved durability and wear resistance. The needle separation produces larger lubrication reservoir and helps achieve higher bearing speeds. The cages are designed with two rollers per pockets to help improve static and dynamic load ratings.

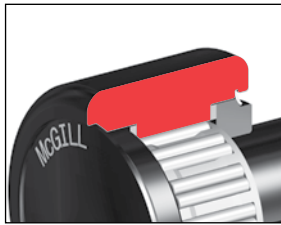

### Heavy Section Outer

The heavy section outer helps support radial loading and provide proper rolling element support.

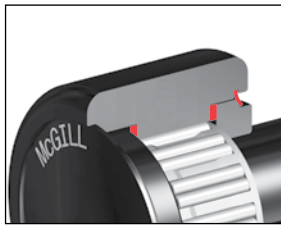

### LUBRI-DISC® Seal

The CAMROL standard for seals, the LUBRI-DISC seal helps keep contaminants out and lubrication in the bearing, with an integral back plate to separate the metal to metal contact between the outer ring and endplate(s) or flange. The back plate feature reduces friction resulting in lower operating temperatures which can extend grease life and allowing for higher operating speeds. The seal also includes vents to help prevent seal blowout during relubrication, while the outer raceway is machined with a reservoir for additional lubricant capacity. The LUBRI-DISC seal option has a good balance of sealing, lubricant capacity, and low drag operation essential to a precision cam follower suited for most industrial applications.

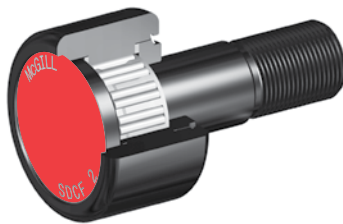

### End Plug Seal

Metallic Plug seal helps keep contamination out of the bearing and resistant to weld spatter, abrasive contaminants and washout. The plug installed into the outer encapsulates the flange side of the bearing resulting in a large grease reservoir and wear resistant bearing seal.



### Cylindrical Outside Diameter (OD)

The cylindrical OD can improve performance in certain applications such as improved track capacity by maximizing the contact area with the track.

## Features and Benefits continued

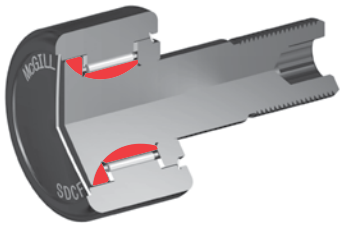

### Zone Hardened Raceways

Heat treatment used to precisely harden working surfaces of the raceway and flange. The hardened surfaces provide support for the rolling element contact stresses, while keeping the core of the inner ductile to help absorb shock loads.



### Hex Hole (Broached)

The hex hole can aid in the installation and removal of stud type cam followers by increasing the holding power over a standard screw driver or milled slot.

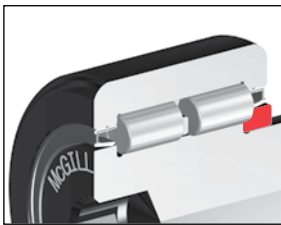

### Hardened Endplate

Similar to the flange, the endplate must provide a seal surface for the LUBRI-DISC seal and resist wear from incidental contact with the outer or rollers. The hardened and ground endplate provides a sealing surface with LUBRI-DISC<sup>®</sup> seal option.



## Features and Benefits

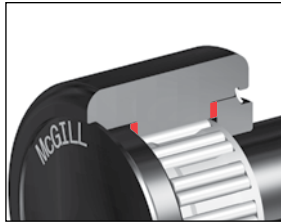

### LUBRI-DISC® Thrust Washer

Utilizing the LUBRI-DISC properties as a back plate to separate the metal to metal contact between the outer ring and endplate(s) or flange. The back plate feature reduces friction resulting in lower operating temperatures which can extend grease life and allowing for higher operating speeds.

### Factory Grease Fill

The cam follower and cam yoke roller bearings are factory lubricated with synthetic grease. Contact Application Engineering when application conditions require special lubricants



### Black Oxide Finish

Bearings have a black oxide finish on all external surfaces.



### Permanent Marking

Part number permanently marked on bearing face, helps bearing identification after years of service.

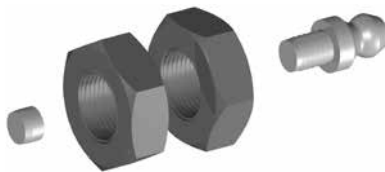

### Installation Accessory Pack

All McGill stud type special duty Cam followers include (2) jam nuts to ensure proper thread type (Metric/ Inch), grease fitting and oil hole plug to help provide proper lubrication path to the rolling elements and prevent contamination from entering the bearing through a unused oil hole.

## Options

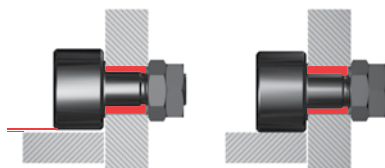

### Eccentric Stud

Eccentric stud option provides a means of adjusting the radial position of the bearing which can improve the load sharing of inline bearing combinations. Cam follower load sharing helps reduce operation costs by reducing premature failures due to overloaded bearings, the need of precise mounting hole location tolerances and providing ability to realign bearing due to track wear.

## **Custom Capabilities**

- *Customer specified factory grease fill*
- *Stud or thread length modifications*
- *Roller diameter variations or tolerances*
- *Cam followers grouped or matched diameter tolerance / run out sets*
- *Custom engineered to order designs*

# McGILL® Special Duty CAMROL Bearings



- Basic Construction Type:** Stud Type Crowned / Cylindrical Outside Diameter
- Rolling Elements:** Retained (Caged) Needle Roller
- Bearing Material:** Bearing Quality Steel
- Seal Type:** Metal Extension Plug and LUBRI-DISC® Seal
- Lubrication:** Synthetic Grease NLGI #2
- System Configuration:** Concentric / Eccentric
- Mounting Feature:** Hex Hole on Thread Face
- Dimensional Interchange:** Standard CAMROL Bearing

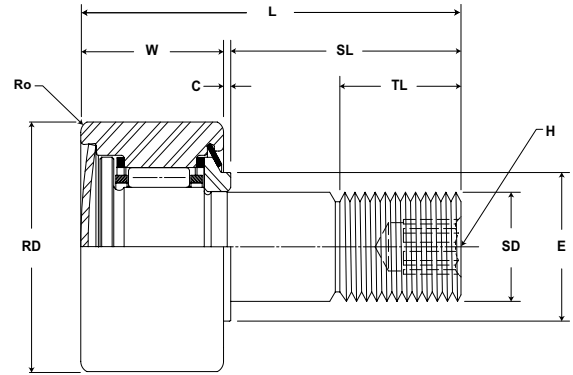

## SDCF

Part No.	RD		W		SD		SL	C	TL	L	Track Roller Dynamic Rating	Track Roller Static Rating
	Roller Diameter		Roller Width		Stud Diameter		Stud Length	Endplate Extension	Minimum Thread Length	Length Overall		
	inch	mm	inch	mm	inch	mm	inch	mm	inch	mm		
	Nom.	Tol.	Nom.	Tol.	Nom.	Tol.	(Ref)	(Ref)	(Ref)	(Ref)	lb/N	lb/N
SDCF 1	1.000 25.40	+0 / -0.001 +0 / - 0.03	.6250 15.875	+0 / -0.010 +0 / - 0.25	.4375 11.113	+0.001 / -0 +0.03 / - 0	1.00 25.4	.03 .8	.50 12.7	1.09 27.8	1,280 5,693	1,450 6,450
SDCF 1 1/4	1.250 31.75	+0 / -0.001 +0 / - 0.03	.7500 19.050	+0 / -0.010 +0 / - 0.25	.5000 12.700	+0.001 / -0 +0.03 / - 0	1.25 31.8	.03 .8	.63 15.9	1.28 32.5	1,630 7,250	2,050 9,118
SDCF 1 1/2	1.500 38.10	+0 / -0.001 +0 / - 0.03	.8750 22.225	+0 / -0.010 +0 / - 0.25	.6250 15.875	+0.001 / -0 +0.03 / - 0	1.50 38.1	.03 .8	.75 19.1	1.53 38.9	2,450 10,898	3,570 15,879
SDCF 1 3/4	1.750 44.45	+0 / -0.001 +0 / - 0.03	1.0000 25.400	+0 / -0.010 +0 / - 0.25	.7500 19.050	+0.001 / -0 +0.03 / - 0	1.75 44.5	.03 .8	.88 22.2	1.78 45.2	3,000 13,344	4,450 19,794
SDCF 2	2.000 50.80	+0 / -0.001 +0 / - 0.03	1.2500 31.750	+0 / -0.010 +0 / - 0.25	.8750 22.225	+0.001 / -0 +0.03 / - 0	2.00 50.8	.03 .8	2.00 50.8	2.16 54.8	4,000 17,792	6,700 29,802
SDCF 2 1/2	2.500 63.50	+0 / -0.001 +0 / - 0.03	1.5000 38.100	+0 / -0.010 +0 / - 0.25	1.0000 25.400	+0.001 / -0 +0.03 / - 0	2.25 57.2	.03 .8	2.25 57.2	2.53 64.3	5,930 26,377	10,400 46,259
SDCF 3	3.000 76.20	+0 / -0.001 +0 / - 0.03	1.7500 44.450	+0 / -0.010 +0 / - 0.25	1.2500 31.750	+0.001 / -0 +0.03 / - 0	2.50 63.5	.03 .8	2.50 63.5	3.03 77.0	10,500 46,704	19,700 87,626
SDCF 4	4.000 101.60	+0 / -0.001 +0 / - 0.03	2.2500 57.150	+0 / -0.010 +0 / - 0.25	1.5000 38.100	+0.001 / -0 +0.03 / - 0	3.50 88.9	.03 .8	3.50 88.9	3.78 96.0	12,700 56,490	23,200 103,194

Clamping torque is based on dry threads. If threads are lubricated, use half of value shown.

Metric dimensions for reference only.

Not all parts are available from stock. Please contact customer service for availability (800) 626-2120.

For more information on bearing capabilities outside of our standard offering, please contact Application Engineering (800) 626-2093.



SDCF

Part No.	H	E	Ro	Housing Bore Diameter		Thread Type	Clamping Torque	Limiting Speed	WT
	Hex Hole	Min. Clamping Diameter	Outer Corner Radius						Bearing Weight
	inch mm		inch mm	inch mm			in-lb	RPM	lb kg
	(Ref)	(Ref)	(Ref)	Nom.	Tol.				
SDCF 1	.25 6.4	.59 15.1	.03 .8	.44 11.1	+0.002/-0.003 +0.0005/-0.0008	7/16-20	250 28	12,500	.16 .07
SDCF 1 1/4	.25 6.4	.83 21.0	.03 .8	.50 12.7	+0.002/-0.003 +0.0005/-0.0008	1/2-20	350 40	8,100	.29 .13
SDCF 1 1/2	.31 7.9	.95 24.2	.06 1.6	.63 15.9	+0.002/-0.003 +0.0005/-0.0008	5/8-18	650 73	6,300	.49 .22
SDCF 1 3/4	.31 7.9	1.11 28.2	.06 1.6	.75 19.1	+0.002/-0.003 +0.0005/-0.0008	3/4-16	1,250 141	5,000	.80 .36
SDCF 2	.44 11.1	1.28 32.5	.09 2.4	.88 22.2	+0.002/-0.003 +0.0005/-0.0008	7/8-14	1,500 170	3,900	1.30 .59
SDCF 2 1/2	.50 12.7	1.56 39.7	.09 2.4	.00 25.4	+0.002/-0.003 +0.0005/-0.0008	1-14	2,250 254	3,100	2.33 1.06
SDCF 3	.75 19.1	2.14 54.4	.13 3.2	.25 31.8	+0.002/-0.003 +0.0005/-0.0008	1 1/4-12	3,450 390	2,200	3.87 1.76
SDCF 4	.75 19.1	2.63 66.7	.13 3.2	.50 38.1	+0.002/-0.003 +0.0005/-0.0008	1 1/2-12	5,000 565	1,900	8.89 4.03

# MCGILL® Special Duty CAMROL Bearings



- Basic Construction Type:** Stud Type Crowned / Cylindrical Outside Diameter
- Rolling Elements:** Retained (Caged) Needle Roller
- Bearing Material:** Bearing Quality Steel
- Seal Type:** Metal Extension Plug and Rubber Lip Seal
- Lubrication:** Synthetic Grease NLGI #2
- System Configuration:** Concentric / Eccentric
- Mounting Feature:** Hex Hole on Thread Face

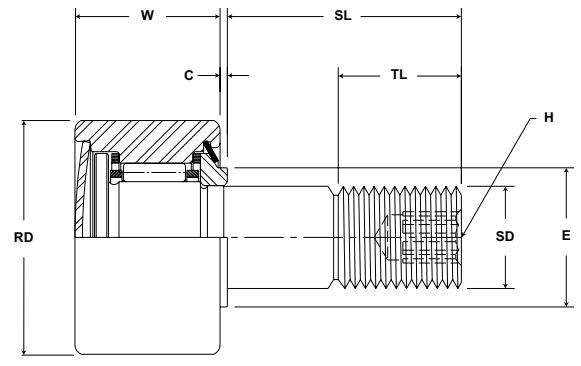

## SDMCF

Part No.	RD		W		SD		SL	C	TL	L	R	ECC	G	BD	Track Roller Dynamic Rating	Track Roller Static Rating
With LUBRI-DISC Seals	Roller Diameter		Roller Width		Stud Diameter		Stud Length	Endplate Extension	Minimum Thread Length	Length Overall	Cylindrical Prefix SDCF-XX	Eccentric Base Modifier SDCF-XX				
	mm inch		mm inch		mm inch		mm inch		mm inch		mm inch	mm inch				
	Nom.	Tol.	Nom.	Tol.	Nom.	Tol.	(Ref)	(Ref)	(Ref)	(Ref)	Radius	(Ref)	+0/- .001 (+0/- .03)	± .001 (± .03)		
SDMCF 25	25.00	+0 / -0.02	16.00	+0 / -0.25	10.00	+0 / -0.02	25	.8	14	27	500 20	N/A	N/A	N/A	5,690 1,279	6,450 1,450
SDMCFE 25	.984	+0 / - 0.001	.630	+0 / - 0.010	.394	+0 / - 0.001	.98	.03	.55	1.1	500 20	.5 .02	10 .39	13 .51		
SDMCF 40	40.00	+0 / -0.02	25.00	+0 / -0.25	16.00	+0 / -0.02	30	.8	17	42	500 20	N/A	N/A	N/A	10,890 2,448	15,900 3,575
SDMCFE 40	1.575	+0 / - 0.001	.984	+0 / - 0.010	.630	+0 / - 0.001	1.18	.03	.67	1.6	500 20	.5 .02	14 .55	20 .79		
SDMCF 50	50.00	+0 / -0.02	30.00	+0 / -0.25	20.00	+0 / -0.02	40	.8	22	51	500 20	N/A	N/A	N/A	17,750 3,991	29,800 6,700
SDMCFE 50	1.969	+0 / - 0.001	1.181	+0 / - 0.010	.787	+0 / - 0.001	1.57	.03	.87	2.0	500 20	1 .04	18 .71	24 .94		
SDMCF 60	60.00	+0 / -0.02	35.00	+0 / -0.25	24.00	+0 / -0.02	50	.8	27	60	500 20	N/A	N/A	N/A	26,380 5,931	46,300 10,409
SDMCFE 60	2.362	+0 / - 0.001	1.378	+0 / - 0.010	.945	+0 / - 0.001	1.97	.03	1.06	2.4	500 20	1 .04	22 .87	28 .10		
SDMCF 80	80.00	+0 / -0.02	45.00	+0 / -0.25	30.00	+0 / -0.02	60	.8	32	76	500 20	N/A	N/A	N/A	4,680 1,052	87,600 19,694
SDMCFE 80	3.150	+0 / - 0.001	1.772	+0 / - 0.010	1.181	+0 / - 0.001	2.36	.03	1.26	3.0	500 20	.5 .06	29 .14	35 .38		
SDMCF 100	100.00	+0 / -0.02	50.00	+0 / -0.25	36.00	+0 / -0.02	80	.8	42	87	800 31	N/A	N/A	N/A	56,500 12,702	103,200 23,201

Clamping torque is based on dry threads. If threads are lubricated, use half of value shown.

Metric dimensions for reference only.  
 Not all parts are available from stock. Please contact customer service for availability (800) 626-2120.  
 For more information on bearing capabilities outside of our standard offering, please contact Application Engineering (800) 626-2093.



SDMCF

Part No.	H	E	Ro	Housing Bore Diameter		Thread Type	Clamping Torque	WT
	Hex Hole	Min. Clamping Diameter	Outer Corner Radius					Bearing Weight
	mm inch		mm inch	mm inch			Nm in-lb	kg lb
	(Ref)	(Ref)	(Ref)	Nom.	Tol.			
SDMCF 25	5	15.1	1	10.00	+0.025/-0.000	M10x1.25	57	.06
SDMCFE 25	.20	.59	.04	.394	+0.001/-0.000		6	.14
SDMCF 40	8	24.1	1	16.00	+0.025/-0.000	M16x1.5	85	.26
SDMCFE 40	.31	.95	.04	.630	+0.001/-0.004		10	.57
SDMCF 50	10	32.5	1	20.00	+0.025/-0.000	M20x1.5	85	.50
SDMCFE 50	.39	1.28	.04	.787	+0.001/-0.008		10	1.10
SDMCF 60	12	39.6	1	24.00	+0.025/-0.000	M24x2	118	.85
SDMCFE 60	.47	1.56	.04	.945	+0.001/-0.012		13	1.86
SDMCF 80	14	54.2	2	30.00	+0.025/-0.000	M30x2	118	1.89
SDMCFE 80	.55	2.13	.08	.181	+0.001/-0.016		13	4.16
SDMCF 100	17	66.5	2	36.00	+0.025/-0.000	M36x3	118	3.36
	.67	2.62	.08	.417	+0.001/-0.020		13	7.40

## McGill TRAKROL Followers

TRAKROL bearings feature black oxide treated bearing steel and utilize either a precision ball or tapered roller bearing insert for longer operating life under combination radial and thrust loads. The capacity for combination loads allow the TRAKROL bearing to be available in plain (cylindrical), V-groove, and flanged O.D. in both stud and yoke styles. Small sizes (<3" OD or point diameter) use sealed ball bearing inserts along with a NYLAPLATE seal for additional protection. Stud type configurations utilize a metal end plug seal on the roller face providing a long lasting seal. Both bearing types provide a large internal grease reservoir along with special sealing makes TRAKROL bearings an excellent choice where reduced maintenance is required.

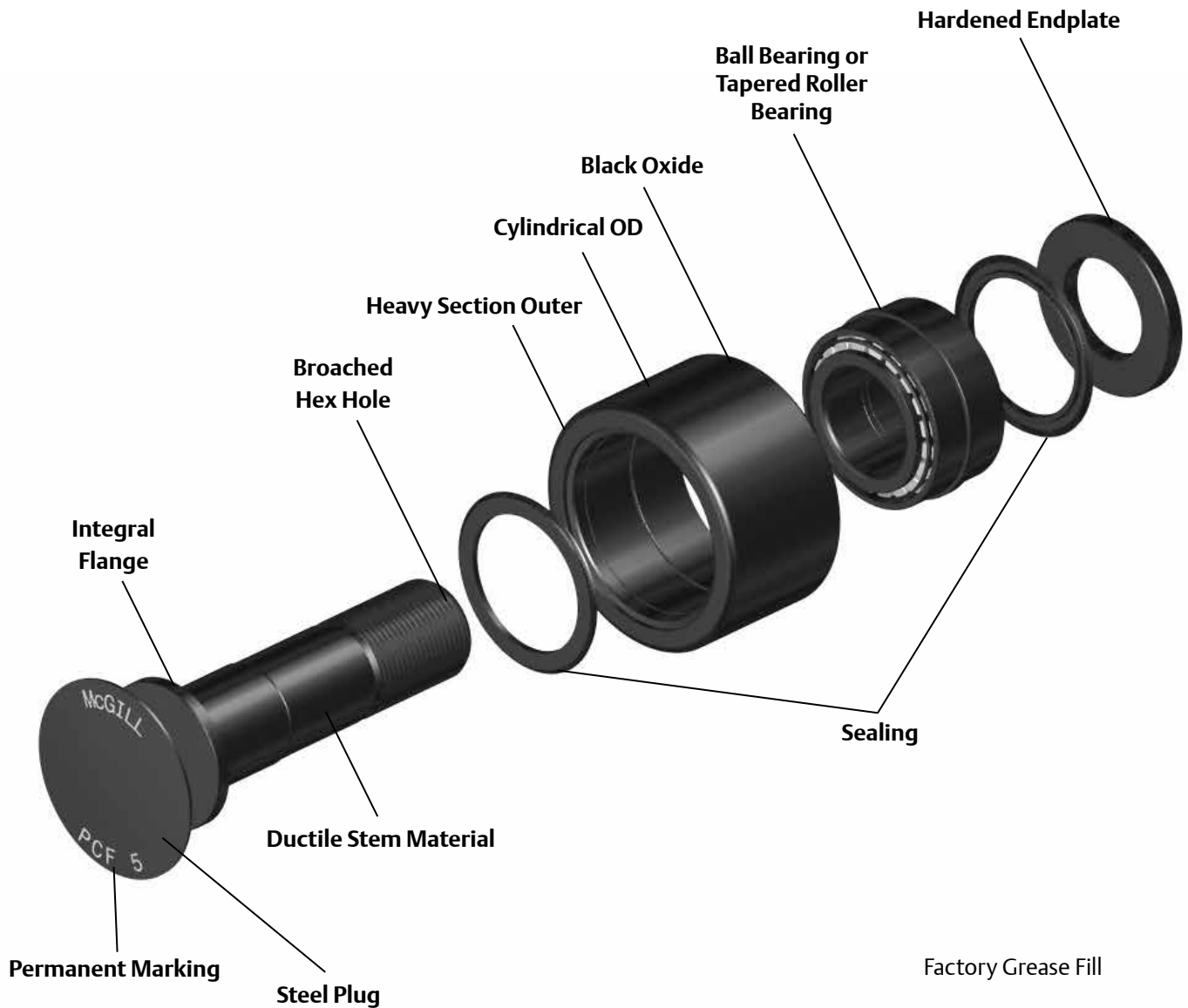

## TRAKROL Nomenclature

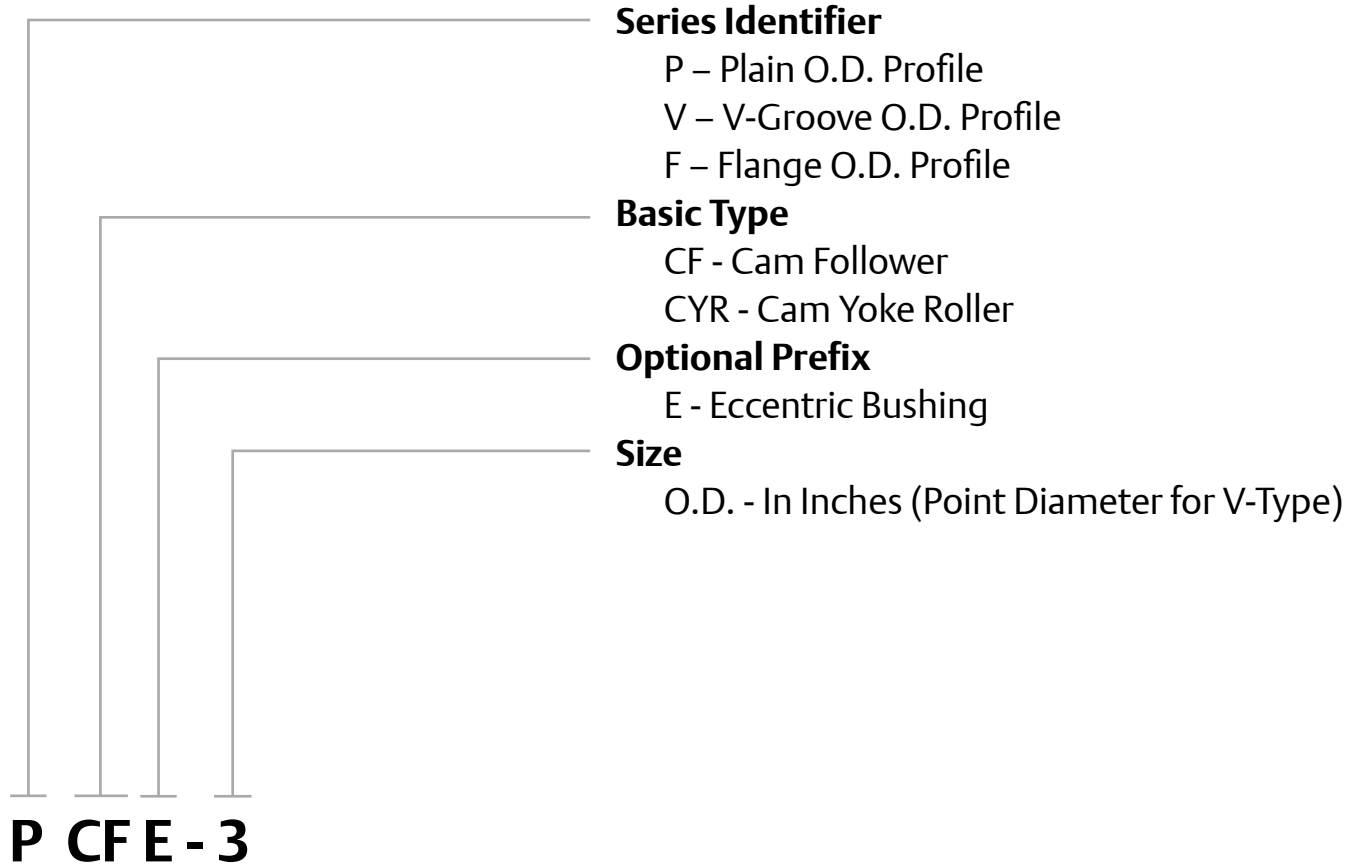



## Features and Benefits

### Configurations

TRAKROL® bearings feature precision ball bearings or tapered roller bearings to help provide longer life when subjected to a combination of radial and thrust loads.



#### Plain Series

Plain OD bearings are generally used to support radial loads. Can also act as a “float” bearing when used in conjunction with a flange or V-Groove type.



#### Flanged Series

Flanged OD bearings are popular in guide rail applications since integral flange help direct the load axially.



#### V-Groove Series

Typically used with “V” shaped tracks for both guidance and radial support. The configuration of the track reduces the amount of sediment build-up on the track.

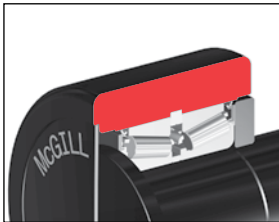

#### Heavy Section Outer

The heavy section outer helps support radial loading and provide proper rolling element support.

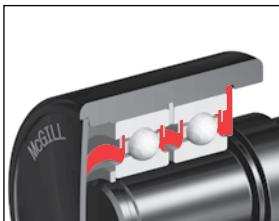

#### Sealing

All TRAKROL bearing utilize rubber lip seals to help improve sealing and grease retention. TRAKROL bearings under 3” feature a ball bearing insert along with a NYLAPLATE wiping seal for addition protection. The NYLAPLATE seal is exclusive to McGill TRAKROL bearings and complements the rubber lip seal provided with the bearing insert.

## Features and Benefits continued



### Steel Plug

Metallic Plug seal helps keep contamination out the bearing and is resistant to weld spatter, abrasive contaminants and washout.



### Cylindrical Outside Diameter (OD)

The cylindrical OD can improve performance in certain applications such as improved track capacity by maximizing the contact area with the track.

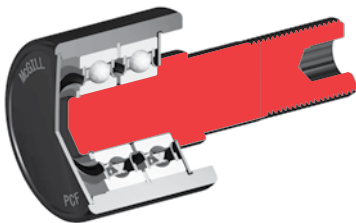

### Ductile Material

Ductile stem helps resist shock loads.

### Factory Grease Fill

The bearings are factory lubricated with medium temperature grease. Contact Application Engineering when application conditions require special lubricants.



### Black Oxide Finish

Bearings have a black oxide finish on all external surfaces.



### Permanent Marking

Part number permanently marked on bearing face, helps bearing identification after years of service.

# MCGILL® TRAKROL Cam Follower Bearings



- Basic Construction Type:** Stud Type Cylindrical Outside Diameter
- Rolling Elements:** Ball or Tapered Roller Bearing Insert
- Bearing Material:** Bearing Quality Steel
- Seal Type:** Metal Extension Plug and Rubber Lip Seal. Ball Bearing has Additional NYLAPLATE Seal
- Lubrication:** Polyurea Thickened Grease NLGI #2
- Stem Configuration:** Concentric / Eccentric
- Mounting Feature:** Hex Hole on Thread Face

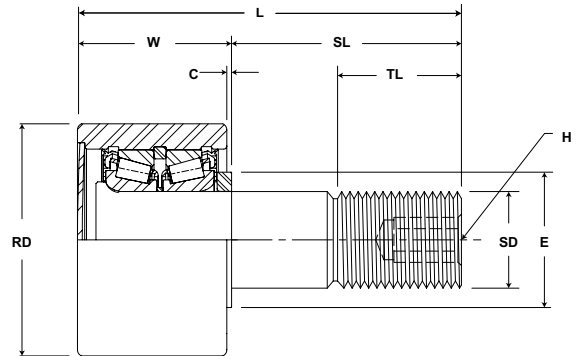

## PCF

Part No.	Insert Type	RD	W	SD		SL	C	TL	L	Track Roller Dynamic Rating	Track Roller Dynamic Thrust Rating*	Track Roller Static Rating
With LUBRI-DISC Seals	Ball or Tapered Roller Bearing	Roller Diameter	Roller Width	Stud Diameter		Stud Length	Endplate Extension	Thread Length	Length Overall	lb/N	lb/N	lb/N
		inch mm	inch mm	inch mm		inch mm	inch mm	inch mm				
		(Ref)	(Ref)	Nom	Tol	(Ref)	(Ref)	Min	(Ref)			
PCF 1 1/2	BB	1.50	1.19	.625	+0 / -0.001	1.500	.06	.75	2.69	2,520	1,320	1,370
PCFE 1 1/2		38.1	30.2	15.9	+0 / - 0.03	38.10	1.6	19.1	68.3	11,209	5,871	6,094
PCF 1 3/4	BB	1.75	1.19	.750	+0 / -0.001	1.750	.06	.88	2.94	2,520	1,320	1,370
PCFE 1 3/4		44.5	30.2	19.1	+0 / - 0.03	44.45	1.6	22.2	74.6	11,209	5,871	6,094
PCF 2	BB	2.00	1.69	.875	+0 / -0.001	2.000	.06	1.13	3.69	3,490	1,830	2,000
PCFE 2		50.8	42.9	22.2	+0 / - 0.03	50.80	1.6	28.6	93.7	15,524	8,140	8,896
PCF 2 1/4	BB	2.25	1.69	.875	+0 / -0.001	2.000	.06	1.13	3.69	3,490	1,830	2,000
PCFE 2 1/4		57.2	42.9	22.2	+0 / - 0.03	50.80	1.6	28.6	93.7	15,524	8,140	8,896
PCF 2 1/2	BB	2.50	1.69	1.00	+0 / -0.001	2.250	.06	1.50	3.94	5,120	2,680	3,120
PCFE 2 1/2		63.5	42.9	25.4	+0 / - 0.03	57.15	1.6	38.1	100.0	22,774	11,921	13,878
PCF 3	TRB	3.00	2.00	1.25	+0 / -0.001	2.500	.06	1.75	4.50	14,300	5,790	16,000
PCFE 3		76.2	50.8	31.8	+0 / - 0.03	63.50	1.6	44.5	114.3	63,606	25,754	71,168
PCF 3 1/4	TRB	3.25	2.00	1.25	+0 / -0.001	2.500	.06	1.75	4.50	14,300	5,790	16,000
PCFE 3 1/4		82.6	50.8	31.8	+0 / - 0.03	63.50	1.6	44.5	114.3	63,606	25,754	71,168
PCF 3 1/2	TRB	3.50	2.00	1.25	+0 / -0.001	2.750	.06	1.75	4.75	14,300	5,790	16,000
PCFE 3 1/2		88.9	50.8	31.8	+0 / - 0.03	69.85	1.6	44.5	120.7	63,606	25,754	71,168
PCF 4	TRB	4.00	2.00	1.25	+0 / -0.001	2.750	.06	1.75	4.75	14,300	5,790	16,000
PCFE 4		101.6	50.8	31.8	+0 / - 0.03	69.85	1.6	44.5	120.7	63,606	25,754	71,168
PCF 4 1/2	TRB	4.50	2.00	1.25	+0 / -0.001	2.750	.06	1.75	4.75	14,300	5,790	16,000
PCF 5		114.3	50.8	31.8	+0 / - 0.03	69.85	1.6	44.5	120.7	63,606	25,754	71,168
PCF 6	TRB	6.00	3.00	2.50	+0 / -0.001	5.500	.06	3.25	8.50	35,800	14,200	62,000
PCF 7		152.4	76.2	63.5	+0 / - 0.03	139.70	1.6	82.6	215.9	159,238	63,162	275,776
PCF 8	TRB	8.00	3.00	2.50	+0 / -0.001	5.500	.06	3.25	8.50	35,800	14,200	62,000
		203.2	76.2	63.5	+0 / - 0.03	139.70	1.6	82.6	215.9	159,238	63,162	275,776

\*Dynamic thrust load rating based on application of a centric, axial load. Fatigue life calculations for combined radial and thrust loading require special considerations and Application Engineering should be contacted.

Metric dimensions for reference only.  
 Not all parts are available from stock. Please contact customer service for availability (800) 626-2120.  
 For more information on bearing capabilities outside of our standard offering, please contact Application Engineering (800) 626-2093.

# TRAKROL Cam Follower Bearings **MCGILL**

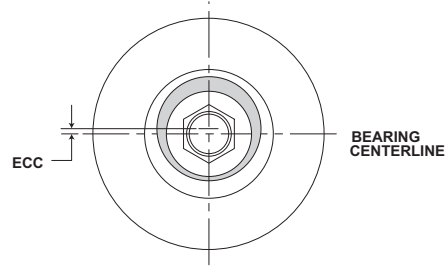
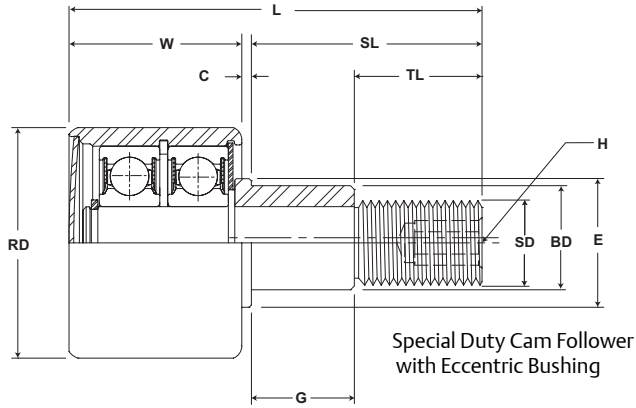

PCF

Part No.	ECC	G	BD	H	E	Housing Bore Diameter		Thread Type	Clamping Torque	WT				
						Hex Hole					Clamping Torque	WT		
						Min. Clamping Diameter							in-lb Nm	lb kg
						in mm								
With LUBRI-DISC Seals	Eccentric Base Modifier PCFE-XX			Hex Hole	Min. Clamping Diameter	Housing Bore Diameter		Thread Type	Clamping Torque	WT				
(Ref)	in mm		(Ref)	(Ref)	Nom.	Tol.								
		+0/-.010	±.001	(Ref)	(Ref)									
PCF 1 1/2	-	-	-	.2500	.75	.6280	±.001 ±.025	5/8-18	650 74	.51 .23				
PCFE 1 1/2	.03 .8	.73 18.5	.875 22.2	6.350	1.13 28.6	.8780 22.301								
PCF 1 3/4	-	-	-	.2500	1.00	.7510	±.001 ±.025	3/4-16	1,250 142	.81 .37				
PCFE 1 3/4	.03 .8	.86 21.7	1.000 25.4	6.350	1.25 31.8	1.0030 25.476								
PCF 2	-	-	-	.3750	1.00	.8760	±.001 ±.025	7/8-14	1,500 170	1.34 .61				
PCFE 2	.03 .8	.98 24.9	1.187 30.1	9.525	1.50 38.1	1.1900 30.226								
PCF 2 1/4	-	-	-	.3750	1.00	.8760	±.001 ±.025	7/8-14	1,500 170	1.72 .78				
PCFE 2 1/4	.03 .8	.98 24.9	1.187 30.1	9.525	1.50 38.1	1.1900 30.226								
PCF 2 1/2	-	-	-	.4375	1.25	1.0010	±.001 ±.025	1-14	2,240 254	2.12 .96				
PCFE 2 1/2	.03 .8	.98 24.9	1.187 30.1	11.113	1.50 38.1	1.1900 30.226								
PCF 3	-	-	-	.4375	1.75	1.2510	±.001 ±.025	1 1/4-12	3,440 388	3.91 1.77				
PCFE 3	.06 1.5	1.23 31.2	1.750 44.5	11.113	2.31 58.7	1.7530 44.526								
PCF 3 1/4	-	-	-	.4375	1.75	1.2510	±.001 ±.025	1 1/4-12	3,440 388	4.60 2.08				
PCFE 3 1/4	.06 1.5	1.23 31.2	1.750 44.5	11.113	2.31 58.7	1.7530 44.526								
PCF 3 1/2	-	-	-	.4375	1.75	1.2510	±.001 ±.025	1 1/4-12	3,440 388	6.25 2.83				
PCFE 3 1/2	.06 1.5	1.36 34.4	1.812 46.0	11.113	2.31 58.7	1.8150 46.101								
PCF 4	-	-	-	.4375	1.75	1.2510	±.001 ±.025	1 1/4-12	3,440 388	7.94 3.60				
PCFE 4	.06 1.5	1.36 34.4	1.812 46.0	11.113	2.31 58.7	1.8150 46.101								
PCF 4 1/2	-	-	-	.4375	1.75	1.2510	±.001 ±.025	1 1/4-12	3,440 388	9.88 4.48				
PCF 5	-	-	-	11.113	3.25 82.6	2.0010 50.825								
PCF 6	-	-	-	.8750	3.25	2.5010	±.001 ±.025	2 1/2-12	5,000 566	30.00 13.61				
PCF 7	-	-	-	22.225	82.6	63.525								
PCF 8	-	-	-	.8750	3.25	2.5010	±.001 ±.025	2 1/2-12	5,000 566	49.00 22.23				
				22.225	82.6	63.525								

Clamping torque is based on dry threads. If threads are lubricated, use half of value shown.

# MCGILL® TRAKROL Cam Follower Bearings



- Basic Construction Type:** Yoke Type Cylindrical Outside Diameter
- Rolling Elements:** Ball or Tapered Roller Bearing Insert
- Bearing Material:** Bearing Quality Steel
- Seal Type:** Rubber Lip
- Lubrication:** Polyurea Thickened Grease NLGI #2

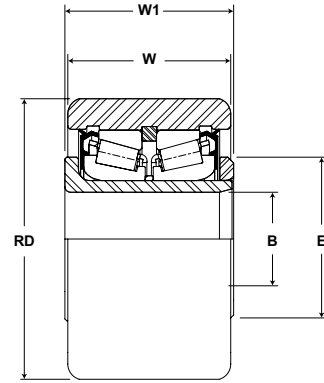

## PCYR

Part No.	Insert Type	RD	W	B		W1	E	Track Roller Dynamic Rating	Thrust Capacity	Track Roller Static Rating	WT				
With LUBRI-DISC Seals	Ball or Tapered Roller Bearing	Roller Diameter	Roller Width	Bore Diameter		Endplate Extension	Min. Clamping Diameter					lb/N	lb/N	lb/N	Bearing Weight
		inch mm	inch mm	inch mm		inch mm	inch mm								
(Ref)	(Ref)	Nom.	Tol.	(Ref)	(Ref)	(Ref)	(Ref)	lb/N	lb/N	lb/N	lb kg				
PCYR 3	TRB	3.00 76.2	1.75 44.5	1.000 25.40	+0.0007 /-0 +0.02 / - 0	1.81 46.0	1.75 44.5	14,300 63,606	5,790 25,754	20,000 88,960	2.57 1.17				
PCYR 3 1/2	TRB	3.50 88.9	2.00 50.8	1.125 28.58	+0.0007 /-0 +0.02 / - 0	2.06 52.4	2.00 50.8	14,300 63,606	5,790 25,754	27,200 120,986	4.41 2.00				
PCYR 4	TRB	4.00 101.6	2.25 57.2	1.250 31.75	+0.0007 /-0 +0.02 / - 0	2.31 58.7	2.25 57.2	14,300 63,606	5,790 25,754	27,200 120,986	6.57 2.98				
PCYR 4 1/2	TRB	4.50 114.3	1.75 44.5	1.000 25.40	+0.0007 /-0 +0.02 / - 0	1.81 46.0	1.75 44.5	14,300 63,606	5,790 25,754	20,000 88,960	9.09 4.12				
PCYR 5	TRB	5.00 127.0	3.75 95.3	1.750 44.45	+0.0007 /-0 +0.02 / - 0	2.85 72.3	3.00 76.2	35,800 159,238	13,300 59,158	58,400 259,763	11.61 5.27				
PCYR 6	TRB	6.00 152.4	3.25 82.6	2.250 57.15	+0.0007 /-0 +0.02 / - 0	3.38 85.7	3.25 82.6	35,800 159,238	14,200 63,162	58,400 259,763	20.47 9.29				

\*Dynamic thrust load rating based on application of a centric, axial load. Fatigue life calculations for combined radial and thrust loading require special considerations and Application Engineering should be contacted.

Metric dimensions for reference only.

Not all parts are available from stock. Please contact customer service for availability (800) 626-2120.

For more information on bearing capabilities outside of our standard offering, please contact Application Engineering (800) 626-2093.



**Cam Follower Engineering see page B-147.**

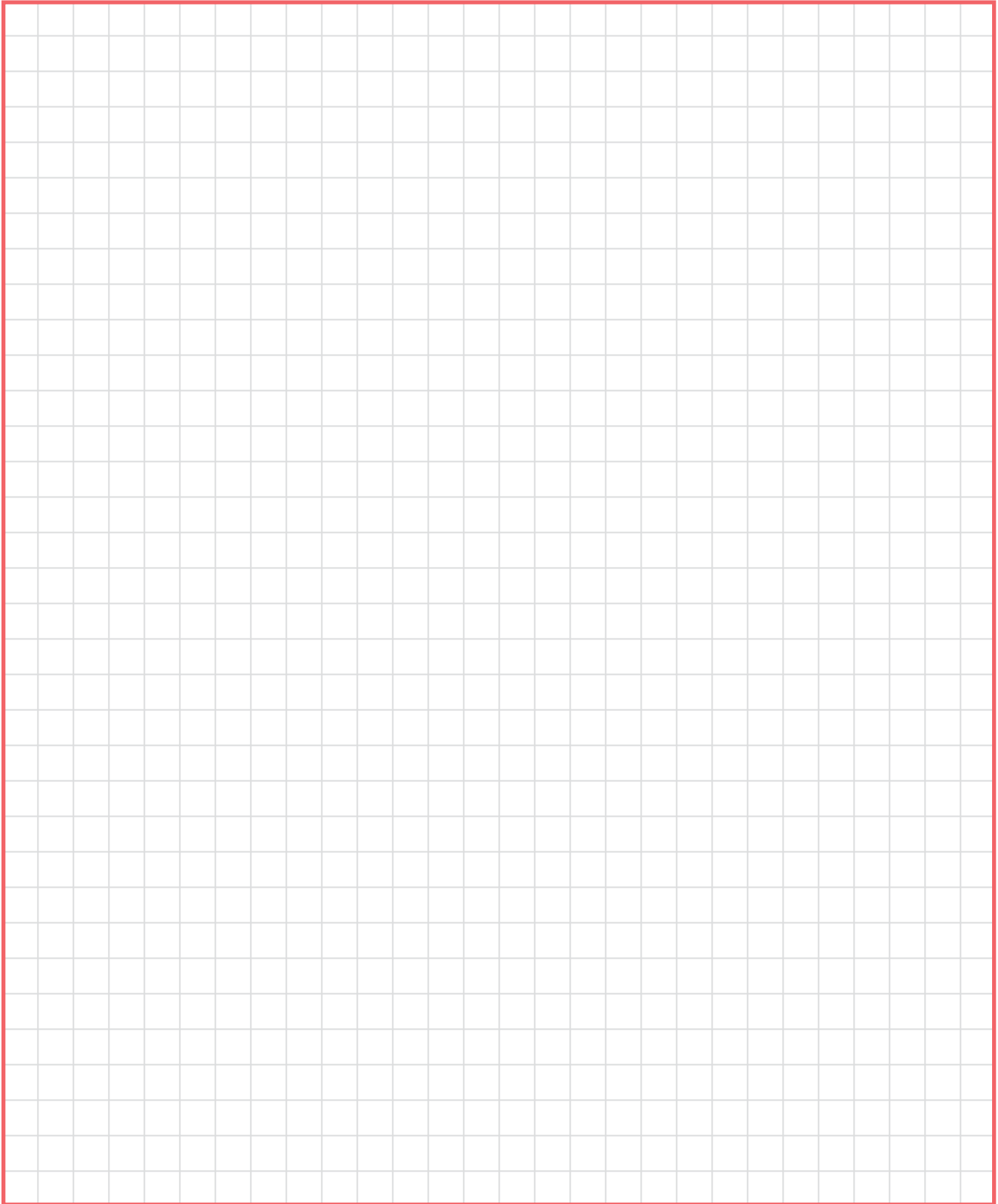

# MCGILL® TRAKROL Cam Follower Bearings



- Basic Construction Type:** Stud Type Flanged Outside Diameter
- Rolling Elements:** Ball or Tapered Roller Bearing Insert
- Bearing Material:** Bearing Quality Steel
- Seal Type:** Metal Extension Plug and Rubber Lip Seal Ball Bearing with Additional NYLAPLATE Seal
- Lubrication:** Polyurea Thickened Grease NLGI #2
- Stem Configuration:** Concentric / Eccentric / Heavy Stud
- Mounting Feature:** Hex Hole on Thread Face

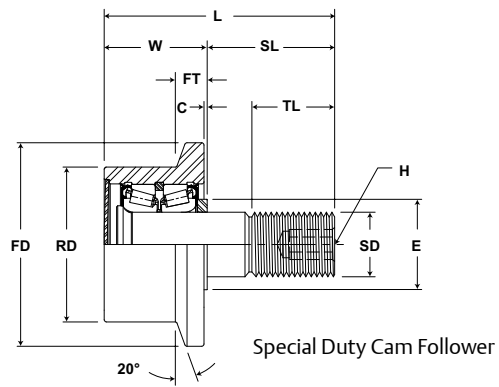

## FCF

Part No.	Insert Type	RD	W	FD	FT	SD		SL	C	TL	L	Track Roller Dynamic Rating	Thrust Capacity	Track Roller Static Rating
With LUBRI-DISC Seals	Ball or Tapered Roller Bearing	Roller Diameter	Roller Width	Flange		Stud Diameter		Stud Length	Endplate Extension	Minimum Thread Length	Length Overall	lb/N	lb/N	lb/N
		inch mm		inch mm		inch mm		inch mm		inch mm				
		(Ref)	(Ref)	(Ref)	(Ref)	Nom	Tol	(Ref)	(Ref)	(Ref)	(Ref)			
FCF 1 1/2 FCFE 1 1/2	BB	1.50 38.1	1.188 30.16	2.19 55.6	.34 8.7	.625 15.9	+0 / -0.001 +0 / - 0.03	1.50 38.1	.06 1.6	.75 19.1	2.69 68.3	2,520 11,209	1,320 5,871	1,370 6,094
FCF 1 3/4 FCFE 1 3/4	BB	1.75 44.5	1.188 30.16	2.44 61.9	.34 8.7	.750 19.1	+0 / -0.001 +0 / - 0.03	1.75 44.5	.06 1.6	.88 22.2	2.94 74.6	2,520 11,209	1,320 5,871	1,370 6,094
FCF 2 1/2 FCFE 2 1/2	BB	2.50 63.5	1.688 42.86	3.19 81.0	.59 15.1	1.00 25.4	+0 / -0.001 +0 / - 0.03	2.25 57.2	.06 1.6	1.50 38.1	3.94 100.0	5,120 22,774	2,680 11,921	3,120 13,878
FCF 2 3/4 FCFE 2 3/4	BB	2.75 69.9	1.688 42.86	3.44 87.3	.59 15.1	1.00 25.4	+0 / -0.001 +0 / - 0.03	2.25 57.2	.06 1.6	1.50 38.1	3.94 100.0	5,120 22,774	2,680 11,921	3,120 13,878
FCF 3 FCFE 3	TRB	3.00 76.2	2.000 50.80	3.94 100.0	.59 15.1	1.25 31.8	+0 / -0.001 +0 / - 0.03	2.50 63.5	.06 1.6	1.75 44.5	4.50 114.3	14,300 63,606	5,790 25,754	16,000 71,168
FCF 3 1/4 FCFE 3 1/4	TRB	3.25 82.6	2.000 50.80	4.19 106.4	.59 15.1	1.25 31.8	+0 / -0.001 +0 / - 0.03	2.50 63.5	.06 1.6	1.75 44.5	4.50 114.3	14,300 63,606	5,790 25,754	16,000 71,168
FCF 3 1/2 FCFE 3 1/2	TRB	3.50 88.9	2.000 50.80	4.44 112.7	.59 15.1	1.25 31.8	+0 / -0.001 +0 / - 0.03	2.75 69.9	.06 1.6	1.75 44.5	4.75 120.7	14,300 63,606	5,790 25,754	16,000 71,168
FCF 4 FCFE 4	TRB	4.00 101.6	2.000 50.80	4.94 125.4	.59 15.1	1.25 31.8	+0 / -0.001 +0 / - 0.03	2.75 69.9	.06 1.6	1.75 44.5	4.75 120.7	14,300 63,606	5,790 25,754	16,000 71,168
FCF 4 1/2	TRB	4.50 114.3	2.000 50.80	5.44 138.1	.59 15.1	1.25 31.8	+0 / -0.001 +0 / - 0.03	2.75 69.9	.06 1.6	1.75 44.5	4.75 120.7	14,300 63,606	5,790 25,754	16,000 71,168
FCF 5	TRB	5.00 127.0	3.000 76.20	5.94 150.8	.72 18.3	1.25 31.8	+0 / -0.001 +0 / - 0.03	4.50 114.3	.06 1.6	2.50 63.5	7.50 190.5	35,800 159,238	13,300 59,158	40,000 177,920
FCF 6	TRB	6.00 152.4	3.000 76.20	6.94 176.2	.72 18.3	2.50 63.5	+0 / -0.001 +0 / - 0.03	5.50 139.7	.06 1.6	3.25 82.6	8.50 215.9	35,800 159,238	14,200 63,162	62,000 275,776
FCF 7	TRB	7.00 177.8	3.000 76.20	7.94 201.6	.72 18.3	2.50 63.5	+0 / -0.001 +0 / - 0.03	5.50 139.7	.06 1.6	3.25 82.6	8.50 215.9	35,800 159,238	14,200 63,162	62,000 275,776
FCF 8	TRB	8.00 203.2	3.000 76.20	8.94 227.0	.72 18.3	2.50 63.5	+0 / -0.001 +0 / - 0.03	5.50 139.7	.06 1.6	3.25 82.6	8.50 215.9	35,800 159,238	14,200 63,162	62,000 275,776

\*Dynamic thrust load rating based on application of a centric, axial load. Fatigue life calculations for combined radial and thrust loading require special considerations and Application Engineering should be contacted.  
 Metric dimensions for reference only.  
 Not all parts are available from stock. Please contact customer service for availability (800) 626-2120.  
 For more information on bearing capabilities outside of our standard offering, please contact Application Engineering (800) 626-2093.

# TRAKROL Cam Follower Bearings **MCGILL**

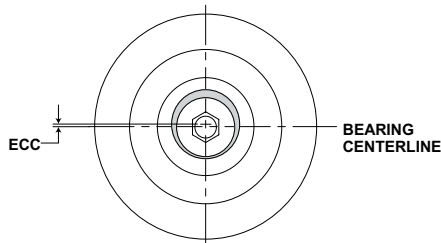
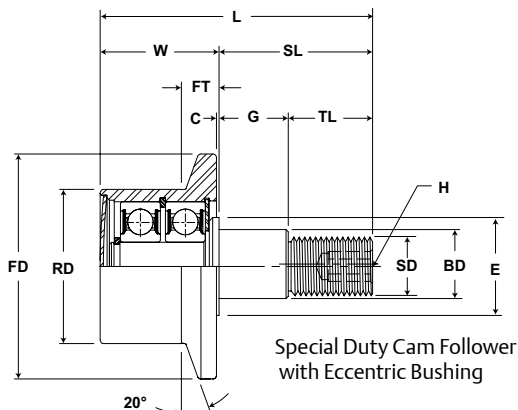

FCF

Part No.	ECC	G	BD	H	E	Housing Bore Diameter		Thread Type	Clamping Torque	WT						
						Base Modifier					Hex Hole	Min. Clamping Diameter	Nom.	Tol.	in-lb Nm	lb kg
						inch mm										
						(Ref)	+0/-.010				±.001	(Ref)	(Ref)	(Ref)	(Ref)	
FCF 1 1/2	-	-	-	.25	.75	.6280	±.0002	5/8-18	650	.63						
FCFE 1 1/2	.03	.730	.875	6.4	19.1	15.900	±.005				74	1.4				
FCF 1 3/4	-	-	-	.25	1.00	.7510	±.0002	3/4-16	1,250	1.00						
FCFE 1 3/4	.03	0.855	1.000	6.4	25.4	19.075	±.005				142	.45				
FCF 2 1/2	-	-	-	.44	1.25	1.0010	±.0002	1-14	2,240	2.75						
FCFE 2 1/2	.03	1.105	1.375	11.1	31.8	25.425	±.005				254	1.25				
FCF 2 3/4	-	-	-	.44	1.25	1.0010	±.0002	1-14	2,240	3.25						
FCFE 2 3/4	.03	1.105	1.375	11.1	31.8	25.425	±.005				254	1.47				
FCF 3	-	-	-	.44	1.75	1.2510	±.0002	1 1/4-12	3,440	4.69						
FCFE 3	.06	1.230	1.750	11.1	44.5	31.775	±.005				388	2.13				
FCF 3 1/4	-	-	-	.44	1.75	1.2510	±.0002	1 1/4-12	3,440	5.42						
FCFE 3 1/4	.06	1.230	1.750	11.1	44.5	31.775	±.005				388	2.46				
FCF 3 1/2	-	-	-	.44	1.75	1.2510	±.0002	1 1/4-12	3,440	6.25						
FCFE 3 1/2	.06	1.355	1.812	11.1	44.5	31.775	±.005				388	2.83				
FCF 4	-	-	-	.44	1.75	1.2510	±.0002	1 1/4-12	3,440	7.94						
FCFE 4	.06	1.355	1.812	11.1	44.5	31.775	±.005				388	3.60				
FCF 4 1/2	-	-	-	.44	1.75	1.2510	±.0002	1 1/4-12	3,440	9.88						
FCF 5	-	-	-	.88	3.25	2.0010	±.0002				2-12	5,000	18.50			
FCF 6	-	-	-	.88	3.25	2.0010	±.0002	2 1/2-12	5,000	30.00						
FCF 7	-	-	-	.88	3.25	2.5010	±.0002				2 1/2-12	5,000	38.00			
FCF 8	-	-	-	.88	3.25	2.5010	±.0002	2 1/2-12	5,000	49.00						
				22.2	82.6	63.525	±.005				566	22.23				

Clamping torque is based on dry threads. If threads are lubricated, use half of value shown.



# MCGILL® TRAKROL Cam Follower Bearings



- Basic Construction Type:** Yoke Type Flanged Outside Diameter
- Rolling Elements:** Tapered Roller Bearing Insert
- Bearing Material:** Bearing Quality Steel
- Seal Type:** Rubber Lip Seal
- Lubrication:** Polyurea Thickened Grease NLGI #2

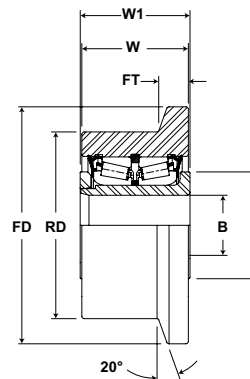

## FCYR

Part No.	Insert Type	RD	W	FD	FT	B		W1	E	Track Roller Dynamic Rating	Thrust Capacity	Track Roller Static Rating	WT	
						Flange								Bore Diameter
						Diameter	Width							
						inch mm	inch mm							inch mm
FCYR 3	TRB	3.00 76.2	1.75 44.5	3.94 100.0	.59 15.1	1.000 25.40	+0.0007 / -0 +0.02 / - 0	1.81 46.0	1.75 44.5	14,300 63,606	5,790 25,754	20,000 88,960	3.28 1.49	
FCYR 3 1/4	TRB	3.25 82.6	1.75 44.5	4.19 106.4	.59 15.1	1.000 25.40	+0.0007 / -0 +0.02 / - 0	1.81 46.0	1.75 44.5	14,300 63,606	5,790 25,754	20,000 88,960	3.93 1.78	
FCYR 3 1/2	TRB	3.50 88.9	2.00 50.8	4.44 112.7	.59 15.1	1.125 28.58	+0.0007 / -0 +0.02 / - 0	2.06 52.4	2.00 50.8	14,300 63,606	5,790 25,754	27,200 120,986	4.97 2.25	
FCYR 4	TRB	4.00 101.6	2.25 57.2	4.94 125.4	.59 15.1	1.250 31.75	+0.0007 / -0 +0.02 / - 0	2.31 58.7	2.25 57.2	14,300 63,606	5,790 25,754	27,200 120,986	7.39 3.35	
FCYR 4 1/2	TRB	4.50 114.3	1.75 44.5	5.44 138.1	.59 15.1	1.000 25.40	+0.0007 / -0 +0.02 / - 0	1.81 46.0	1.75 44.5	14,300 63,606	5,790 25,754	20,000 88,960	10.19 4.62	
FCYR 5	TRB	5.00 127.0	3.75 95.3	5.94 150.8	.72 18.3	1.750 44.45	+0.0007 / -0 +0.02 / - 0	2.85 72.3	3.00 76.2	35,800 159,238	13,300 59,158	58,400 259,763	12.99 5.89	
FCYR 6	TRB	6.00 152.4	3.25 82.6	6.94 176.2	.72 18.3	2.250 57.15	+0.0007 / -0 +0.02 / - 0	3.38 85.7	3.25 82.6	35,800 159,238	14,200 63,162	58,400 259,763	20.04 9.09	

\*Dynamic thrust load rating based on application of a centric, axial load. Fatigue life calculations for combined radial and thrust loading require special considerations and Application Engineering should be contacted.

Metric dimensions for reference only.

Not all parts are available from stock. Please contact customer service for availability (800) 626-2120.

For more information on bearing capabilities outside of our standard offering, please contact Application Engineering (800) 626-2093.



**Cam Follower Engineering see page B-147.**

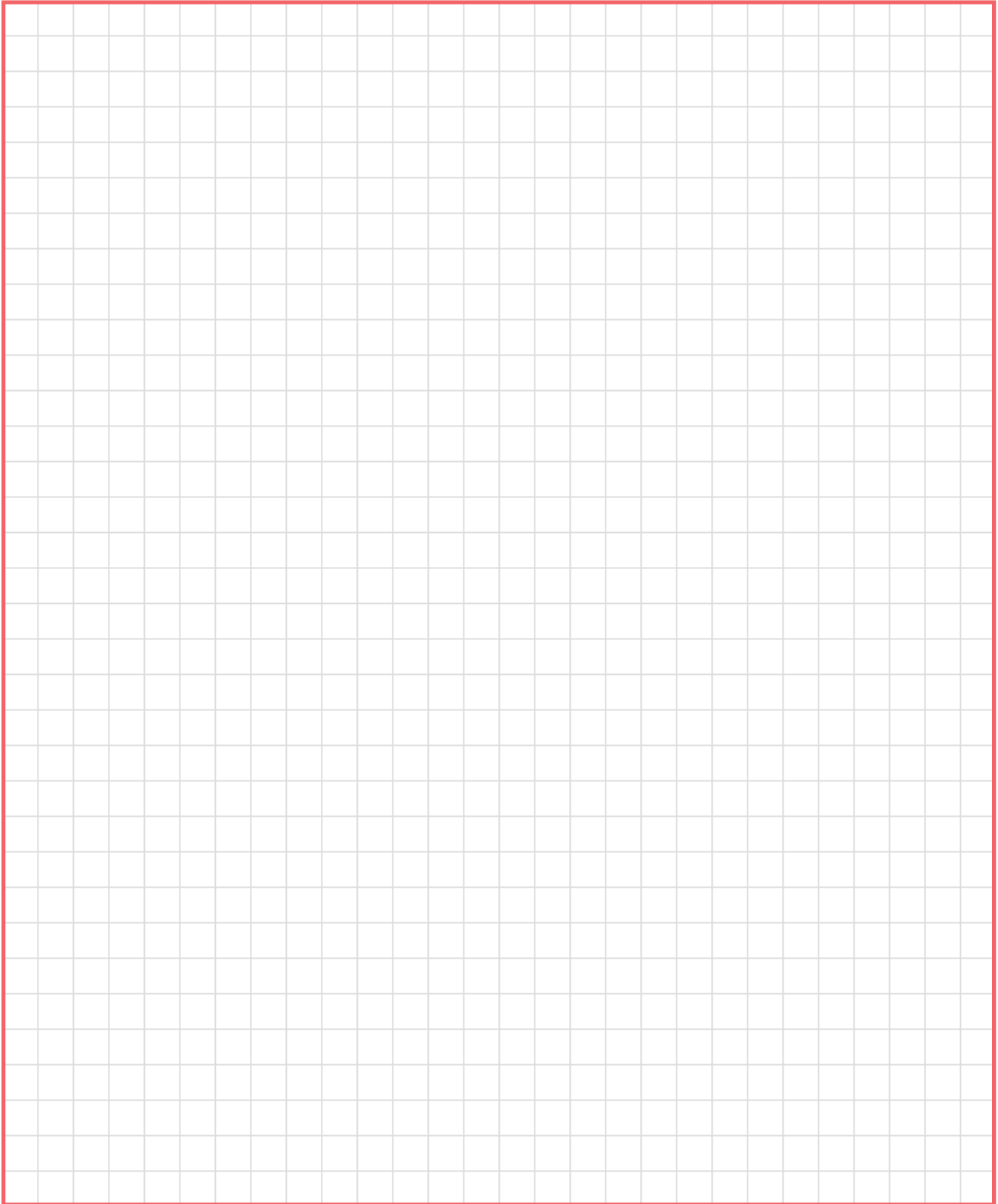

# MCGILL® TRAKROL Cam Follower Bearings



- Basic Construction Type:** Stud Type V-Grooved Outside Diameter
- Rolling Elements:** Ball or Tapered Roller Bearing Insert
- Bearing Material:** Bearing Quality Steel
- Seal Type:** Metal Extension Plug and Rubber Lip Seal Ball
- Lubrication:** Polyurea Thickened Grease NLGI #2
- Stem Configuration:** Concentric / Eccentric
- Mounting Feature:** Hex Hole on Thread Face

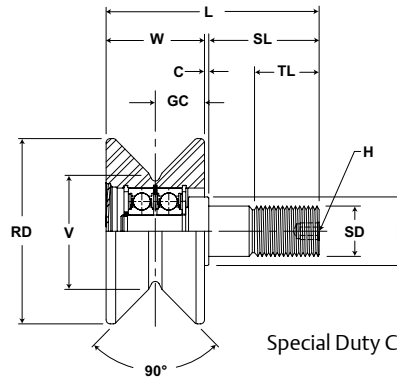

Special Duty Cam Follower

## VCF

Part No.	Insert Type	RD	W	V	GC	SD		SL	C	L		ECC	G	BD
With LUBRI-DISC Seals	Ball or Tapered Roller Bearing	Roller Diameter	Roller Width	Point Diameter	Groove Center	Stud Diameter		Stud Length	Endplate Extension	Length Overall	Thread Length	Eccentric Base Modifier VCFE-XX		
		inch mm	inch mm	inch mm	inch mm	inch mm	inch mm	inch mm	inch mm	inch mm	inch mm	inch mm		
		(Ref)	(Ref)	(Ref)	(Ref)	Nom.	Tol.	(Ref)	(Ref)	(Ref)	(Ref)	(Ref)	+0/- .010	±.001
VCF 2 1/2	BB	2.50 63.5	1.31 33.3	1.50 38.1	.69 17.5	1.00 25.4	+0/-0.001 +0/- 0.03	1.75 44	0.06 2	2.94 75	0.88 22	-	-	-
VCFE 2 1/2												.03 1	.86 22	1.00 25
VCF 3 1/2	BB	3.50 88.9	1.69 42.9	2.25 57.2	.88 22.2	1.25 31.8	+0/-0.001 +0/- 0.03	2.00 51	0.06 2	3.69 94	1.13 29	-	-	-
VCFE 3 1/2													.03 1	.98 25
VCF 4 1/2	TRB	4.50 114.3	2.00 50.8	3.00 76.2	1.00 25.4	1.25 31.8	+0/-0.001 +0/- 0.03	2.50 64	0.06 2	4.50 114	1.75 44	-	-	-
VCFE 4 1/2													.06 2	1.23 31
VCF 5 1/2	TRB	5.50 139.7	2.00 50.8	4.00 101.6	1.00 25.4	1.25 31.8	+0/-0.001 +0/- 0.03	2.75 70	0.06 2	4.75 121	1.75 44	-	-	-
VCFE 5 1/2													.06 2	1.36 34
VCF 6 1/2	TRB	6.50 165.1	3.00 76.2	5.00 127.0	1.50 38.1	2.00 50.8	+0/-0.001 +0/- 0.03	4.50 114	0.06 2	7.50 191	2.50 64	-	-	-
VCF 7 1/2	TRB	7.50 190.5	3.00 76.2	6.00 152.4	1.50 38.1	2.50 63.5	+0/-0.001 +0/- 0.03	5.50 140	0.06 2	8.50 216	3.25 83	-	-	-
VCF 8 1/2	TRB	8.50 215.9	3.00 76.2	7.00 177.8	1.50 38.1	2.50 63.5	+0/-0.001 +0/- 0.03	5.50 140	0.06 2	8.50 216	3.25 83	-	-	-

\*Dynamic thrust load rating based on application of a centric, axial load. Fatigue life calculations for combined radial and thrust loading require special considerations and Application Engineering should be contacted.

Metric dimensions for reference only.

Not all parts are available from stock. Please contact customer service for availability (800) 626-2120.

For more information on bearing capabilities outside of our standard offering, please contact Application Engineering (800) 626-2093.

# TRAKROL Cam Follower Bearings **McGILL**

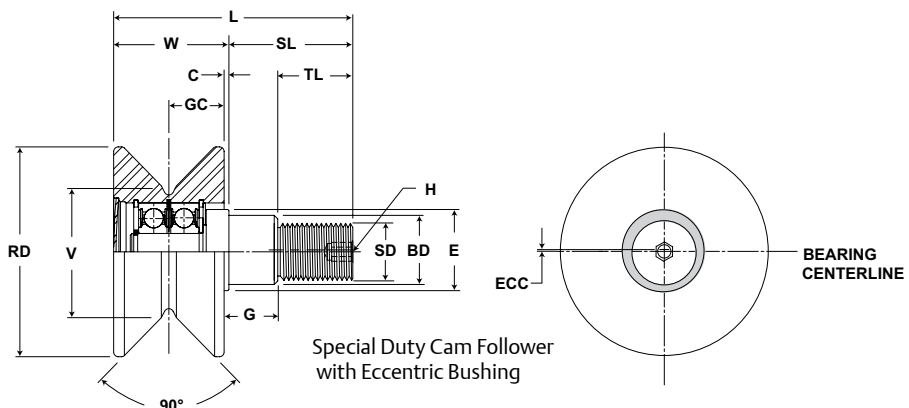

VCF

Track Roller Dynamic Rating	Thrust Capacity	Track Roller Static Rating	H	E	Housing Bore Diameter		Thread Type	Clamping Torque	WT
			Hex Hole	Min. Clamping Diameter					Bearing Weight
			lb/N	lb/N	lb/N	inch mm		inch mm	Nom.
2,520 11,209	1,320 5,871	1,370 6,094	.25 6	1.0 25	.7510 19	+0.002/-0.003 +0.0005/-0.0008	3/4-16	1,250 142	1.3 .59
					1.003 25.47	±.001 ±.025			
3,490 15,524	1,830 8,140	2,000 8,896	.38 10	1.0 25	.8760 22	+0.002/-0.003 +0.0005/-0.0010	7/8-14	1,500 170	3.2 1.45
					1.190 30.23	±.001 ±.025			
14,300 63,606	5,790 25,754	16,000 71,168	.44 11	1.75 44	1.2510 32	+0.002/-0.003 +0.0005/-0.0013	1 1/4-12	3,440 388	6.8 3.08
					1.753 44.52	±.001 ±.025			
14,300 63,606	5,790 25,754	16,000 71,168	.44 11	1.75 44	1.2510 32	+0.002/-0.003 +0.0005/-0.0015	1 1/4-12	3,440 388	10.7 4.85
					1.815 46.10	±.001 ±.025			
35,800 159,238	13,300 59,158	40,000 177,920	.88 22	3.25 83	2.0010 51	+0.002/-0.003 +0.0005/-0.0017	2-12	5,000 566	26.1 11.84
35,800 159,238	14,200 63,162	62,000 275,776	.88 22	3.25 83	2.5010 64	+0.002/-0.003 +0.0005/-0.0018	2 1/2-12	5,000 566	34.0 15.42
35,800 159,238	14,200 63,162	62,000 275,776	.88 22	3.25 83	2.5010 64	+0.002/-0.003 +0.0005/-0.0019	2 1/2-12	5,000 566	45.0 20.41

Clamping torque is based on dry threads. If threads are lubricated, use half of value shown.

# MCGILL® TRAKROL Cam Follower Bearings



- Basic Construction Type:** Yoke Type V-Grooved Outside Diameter
- Rolling Elements:** Tapered Roller Bearing Insert
- Bearing Material:** Bearing Quality Steel
- Seal Type:** Rubber Lip Seal
- Lubrication:** Polyurea Thickened Grease NLGI #2

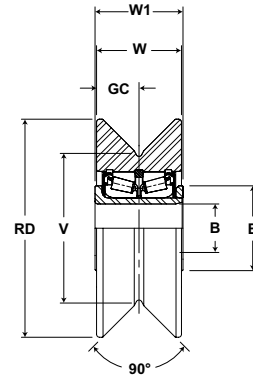

## VCYR

Part No.	Insert Type	RD	W	V	GC	B		W1	E	Track Roller Dynamic Rating	Thrust Capacity	Track Roller Static Rating	WT
With LUBRI-DISC Seals	Ball or Tapered Roller Bearing	Roller Diameter	Roller Width	Point Diameter	Groove Center	Bore Diameter		Endplate Extension	Min. Clamping Diameter	lb/N	lb/N	lb/N	Bearing Weight
		inch mm		inch mm		inch mm		inch mm					
		(Ref)	(Ref)	(Ref)	(Ref)	Nom	Tol	(Ref)	(Ref)				
VCYR 4 1/2	TRB	4.50 114	1.75 44	3.00 76	1.00 25	1.0000 25.40	+0.0007/-0 +0.02/- 0	1.81 46	1.75 44	14,300 63,606	5,790 25,754	20,000 88,960	4.98 2.26
VCYR 5 1/2	TRB	5.50 140	2.25 57	4.00 102	1.00 25	1.2500 31.75	+0.0007/-0 +0.02/- 0	2.31 59	2.25 57	14,300 63,606	5,790 25,754	27,100 120,541	11.11 5.03
VCYR 6 1/2	TRB	6.50 165	2.75 70	5.00 127	1.50 38	1.7500 44.45	+0.0007/-0 +0.02/- 0	2.88 73	3.00 76	35,800 159,238	13,300 59,158	56,200 249,978	24.72 11.21

\*Dynamic thrust load rating based on application of a centric, axial load. Fatigue life calculations for combined radial and thrust loading require special considerations and Application Engineering should be contacted.

Metric dimensions for reference only.

Not all parts are available from stock. Please contact customer service for availability (800) 626-2120.

For more information on bearing capabilities outside of our standard offering, please contact Application Engineering (800) 626-2093.



**Cam Follower Engineering see page B-147.**

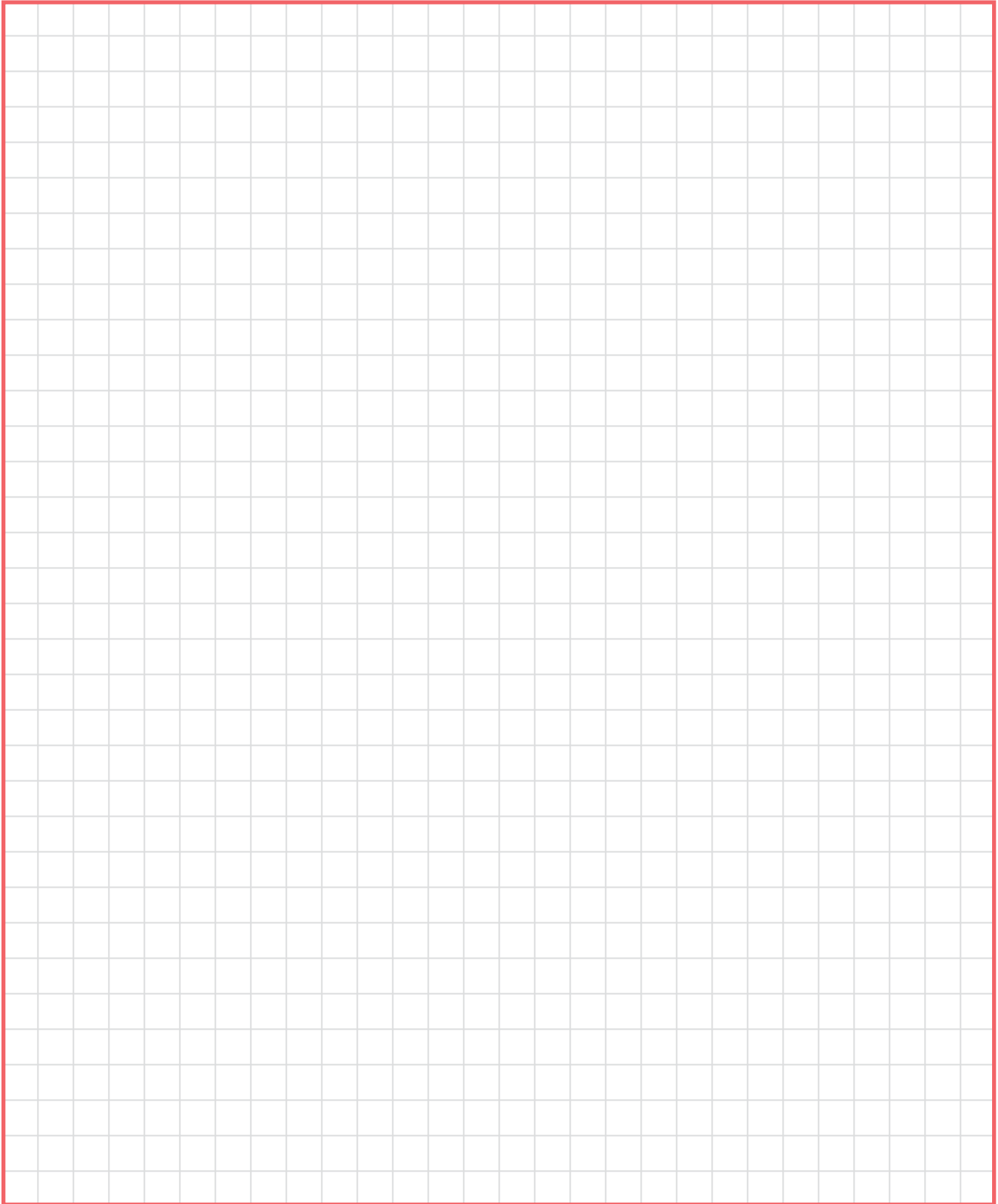

## Load Ratings and Life

### Life Calculations

The L10 (rating) life for any given application and bearing selection can be calculated in terms of millions of revolutions by using the bearing Basic Dynamic Rating and applied radial load (or, equivalent radial load in the case of radial bearing applications having combined radial and thrust loads). The L10 life for any given application can be calculated in terms of hours, using the bearing Basic Dynamic Rating, applied load (or equivalent radial load) and suitable speed factors, by the following equation:

$$L_{10} = \left(\frac{C}{P}\right) \times \frac{1,000,000}{60 \times n} = \left(\frac{C}{P}\right)^{10/3} \times \frac{16667}{n}$$

Where:

$L_{10}$  = The # of hours that 90% of identical bearings under ideal conditions will operate at a specific speed and condition before fatigue is expected to occur.

C = Basic Dynamic Rating (lbs)  
1,000,000 Revolutions

P = Constant Equivalent Radial Load (lbs)

n = Speed (RPM)

Additionally, the ABMA provides application factors for all types of bearings which need to be considered to determine an adjusted Rated Life ( $L_{na}$ ). L10 life rating is based on laboratory conditions yet other factors are encountered in actual bearing application that will reduce bearing life.  $L_{na}$  life rating takes into account reliability factors, material type, and operating conditions.

$$L_{na} = a_1 \times a_2 \times a_3 \times L_{10}$$

Where:

$L_{na}$  = Adjusted Rated Life.

$a_1$  = Reliability Factor. Adjustment factor applied where estimated fatigue life is based on reliability other than 90% (See Table No 1).

Table No. 1 Life Adjustment Factor for Reliability

Reliability %	$L_{na}$	$a_1$
90	L10	1
95	L5	0.62
96	L4	0.53
97	L3	0.44
98	L2	0.33
99	L1	0.21
50	L50	5

$a_2$  = Material Factor. Life adjustment for bearing race material. Power Transmission Solutions bearing races are manufactured from bearing quality steel. Therefore the  $a_2$  factor is 1.0.

$a_3$  = Life Adjustment Factor for Operating Conditions. This factor should take into account the adequacy of lubricant, presence of foreign matter, conditions causing changes in material properties, and unusual loading or mounting conditions. Assuming a properly selected and mounted bearing having adequate seals and lubricant, the  $a_3$  factor should be 1.0.

# Load Ratings and Life Continued

Vibration and shock loading can act as an additional loading to the steady expected applied load. When shock or vibration is present, an a3 Life Adjustment Factor can be applied. Shock loading has many variables which often are not easily determined. Typically, it is best to rely on one's experience with the particular application. Consult Application Engineering for assistance with applications involving shock or vibration loading.

The a3 factor takes into account a wide range of application and mounting conditions as well as bearing features and design. Accurate determination of this factor is normally achieved through testing and in-field experience. Power Transmission Solutions offers a wide range of options which can maximize bearing performance. Consult Application Engineering for more information.

## Variable Load Formula

Root mean load (RML) is to be used when a number of varying loads are applied to a bearing for varying time limits. Maximum loading still must be considered for bearing size selection.

$$RML^* = \sqrt[10/3]{\frac{(L_1^{10/3} N_1) + (L_2^{10/3} N_2) + (L_3^{10/3} N_3)}{100}}$$

Where:

RML = Root Mean Load (lbs.)

L<sub>1</sub>, L<sub>2</sub>, etc. = Load in pounds

N<sub>1</sub>, N<sub>2</sub>, etc. = Percent of total time operated at loads L<sub>1</sub>, L<sub>2</sub>, etc.

\* Apply RML to rating at mean speed to determine resultant life.

## Mean Speed Formula

The following formula is to be used when operating speed varies over time.

$$\text{Mean Speed} = \frac{S_1 N_1 + S_2 N_2 + S_3 N_3}{100}$$

S<sub>1</sub>, S<sub>2</sub>, etc = Speeds in RPM

N<sub>1</sub>, N<sub>2</sub>, etc = Percentage of total time operated at speeds S<sub>1</sub>, S<sub>2</sub>, etc



## Load Ratings and Life Continued

### Bearing Life In Oscillating Applications

The equivalent rotative speed (ERS) is used in life calculations when the bearing does not make complete revolutions during operation. The ERS is then used as the bearing operating speed in the calculation of the L10 (Rating) Life. The formula is based on sufficient angular rotation to have roller paths overlap.

$$\begin{aligned} \text{ERS} &= \text{Equivalent Rotative Speed} \\ \text{N} &= \text{Total number of degrees per minute through} \\ &\quad \text{which the bearing will rotate.} \\ \text{ERS} &= \frac{\text{N}}{360} \end{aligned}$$

In the above formula, allowance is made for the total number of stress applications on the weakest race per unit time, which, in turn, determines fatigue life and the speed factors. The theory behind fretting corrosion is best explained by the fact that the rolling elements in small angles of oscillation retrace a path over an unchanging area of the inner or outer races where the lubricant is prevented by inertia from flowing in behind the roller as the bearing oscillates in one direction. Upon reversal, this small area of rolling contact is traversed by the same roller in the dry state. The friction of the two unlubricated surfaces causes fretting corrosion and produces failures which are unpredictable from a normal life standpoint.

With a given bearing selected for an oscillating application, the best lubrication means is a light mineral oil under positive flow conditions. With a light oil, there is a tendency for all areas in the bearing load zone to be immersed in lubricant at all times. The full flow lubrication dictates that any oxidized material which may form is immediately carried away by the lubricant, and since these oxides are abrasive, further wear tends to be avoided. If grease lubrication must be used, it is best to consult with either the bearing manufacturer or the lubricant manufacturer to determine the best possible type of lubricant. Greases have been compounded to resist the detrimental effect of fretting corrosion for such applications.

### Static Load Rating

The “static load rating” for rolling element bearings is that uniformly distributed static radial load acting on a non-rotating bearing, which produces a contact stress of 580,000 psi (roller bearings) or 607,000 psi (ball bearings) at the center of the most heavily loaded rolling element. At this stress level, plastic deformation begins to be significant. Experience has shown that the plastic deformation at this stress level can be tolerated in most bearing applications without impairment of subsequent bearing operation. In certain applications where subsequent rotation of the bearing is slow and where smoothness and friction requirements are not too exacting, a higher static load limit can be tolerated. Where extreme smoothness is required or friction requirements are critical, a lower static load limit may be necessary.

### Minimum Bearing Load

Skidding, or sliding, of the rolling elements on the raceway instead of a true rolling motion can cause excessive wear. Applications with high speeds and light loading are particularly prone to skidding. As a general guideline, rolling element bearings should be radially loaded at least 2% of Basic Dynamic Rating. For applications where load is light relative to the bearings dynamic load rating, consult Application Engineering for assistance.

# Load Ratings and Life Continued

## Bushing Type Cam Follower/ Yoke Roller

Because bushing type bearings operate with sliding motion instead of rolling motion, they do not follow standard bearing life theory. Instead, life is based on an acceptable wear rate based on operating load and speed for the given bearing size. The following chart and examples are provided to aid in selection of bushing type cam followers

To determine maximum bearing capacity at a given speed, read vertical load scale under basic bearing size under consideration at proper speed.

### Example:

Determine load capacity of BCF-3/4-S at 100 RPM. Read down vertical load scale under basic 3/4 size to intersection of horizontal line for maximum speed of 100 RPM. Load rating would be 100 pounds.

To determine minimum bearing size required for application, draw horizontal line through application speed until application load can be read on one of the vertical load scales. The basic bearing size can then be read at the top of the column.

### Example:

Application speed = 200 RPM

Application load = 50 pounds

Minimum basic bearing size required would be a BCF or BCYR - 1 1/4-S.

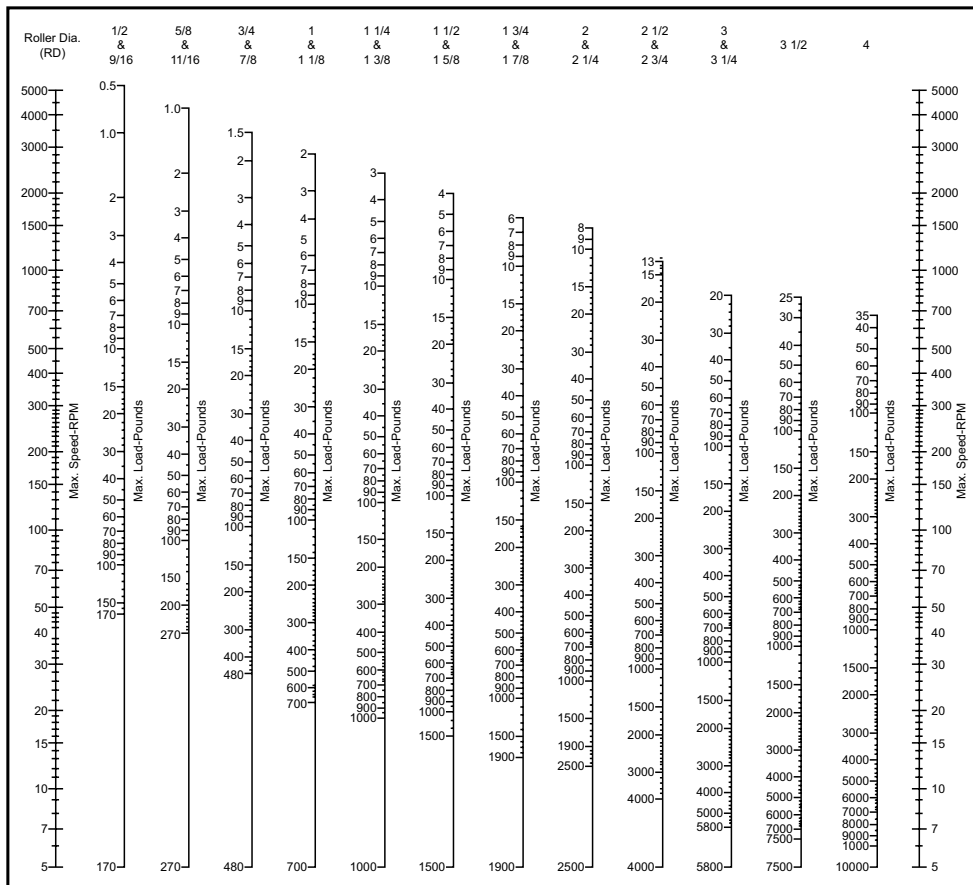

Values based on continuous rotation and no lubrication

## Cam Follower Engineering Section

### Load Ratings

ABMA and ISO Dynamic and Static Load Ratings, when listed, follow standard calculations as accepted by ABMA and ISO. These ratings are based on a bearing that is fully supported within a rigid housing. Cam follower and track roller bearings generally operate with an unsupported outer ring in rolling contact with a cam or track. As such, these standard ratings cannot be applied. ABMA and ISO dynamic and static load ratings when listed in the dimension tables for cam follower and track roller bearings are therefore provided for comparison only.

When listed, Track Roller Dynamic Load Rating is to be used for the purpose of bearing size selection or theoretical bearing life calculation. The track roller rating considers the unsupported outer ring condition of the cam follower or track roller bearing design. The Maximum Permissible Load as listed considers stud strength. Static loads should not exceed the Maximum Permissible Load.

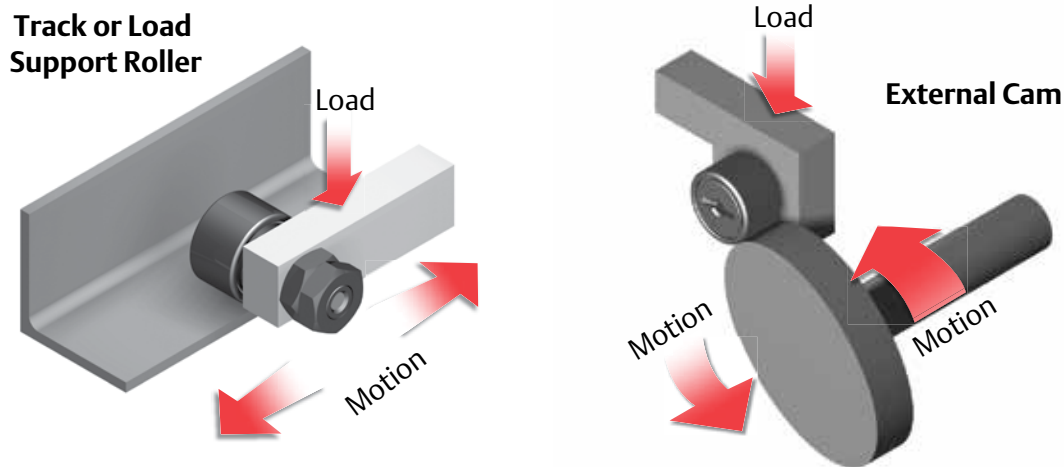

Track Roller Static Load Rating as listed considers internal rolling element contact stress. Static loads greater than the Static Rating may impair subsequent dynamic operations.

### Load Considerations

In any bearing application, radial, shock and thrust loads must be taken into consideration to help assure successful performance.

### Radial Load

Maximum dynamic radial load should not exceed 50% of Basic Dynamic Rating. If radial load and/or root mean load exceed 50% of Basic Dynamic Rating, life calculations must be reviewed by Application Engineering. If dynamic radial loads exceed 25% of Basic Dynamic Rating, consideration should be given to use of heavy stud option (CFH series) or yoke type (CYR, CYR-CR, CYRD, MCYR, MCYRD series). Applications involving reversing radial loads should be reviewed by Application Engineering.

# Cam Follower Engineering Section continued

## Shock Load

The load ratings in this catalog are based on uniform and steady loading. When the loading is of a shock nature and/or vibration is present, or the loading is indeterminate, a bearing of greater rating must be selected. If such conditions exist, it is advisable to use the Load Factor as shown in the table below. The actual bearing load should be multiplied by the appropriate load factor and the resultant value used to calculate the bearing life or to determine the required Basic Dynamic Rating as described in the General Engineering Section.

Type of Load	Load Factor
Uniform and Constant	1.0
Light Shock	1.5
Moderate Shock	2.0
Heavy Shock	3.0

## Thrust Load Series CF, CFH, CYR, BCF, BCYR, CF-CR, CYR-CR, SDCF, SDMCF, MCF, MCYR

Designed for radial loads, these series' bearings do not have design features that help them to support thrust loading. Therefore, these cam followers and track rollers should be mounted to minimize, or preferably eliminate, the possibility of any thrust loading on the outer ring.

## Series CFD, CYRD, MCFD, MCYRD

These series provide improved thrust capability versus the above needle rolling element and bushing type designs. They are designed using a double row of full complement cylindrical rolling elements. Their construction helps to support incidental thrust sometimes associated with cam follower and track roller applications.

## Series PCF, FCF, VCF, PCYR, FCYR, VCYR

These series use radial ball and tapered roller bearing assemblies. These constructions make possible successful bearing operation with various combinations of radial and thrust loads. Refer to dimension tables for specific thrust load ratings.

## Track Design

Since either cam followers or cam yoke rollers are merely one component of a two-piece bearing construction involving (1) the cam follower or cam yoke roller and (2) the track or cam on which it operates, some consideration must be given to selection of track or cam materials, since they must be considered bearing components and have a direct effect upon ultimate life and performance of the cam roll application. From the standpoint of track design where bearings are used as support or guide rollers, it is often difficult to obtain high hardness and tensile strength values for the machine members against which the bearings operate. In most applications, in the interest of economy, relatively soft structural materials can be applied. Where dimensional accuracy is not extremely critical, the work hardening of ferrous, low carbon track materials, accompanied by relatively small amounts of wear-in of the bearing into the track surface generally results in satisfactory bearing performance. It is common, for instance, in the application of cam follower or cam yoke roller bearings as lift truck mast rollers to employ formed structural steel sections as bearing track support members. The wearing-in and work hardening of the track surface generally results in a satisfactory bearing application, providing loads are not excessive.

## Cam Follower Engineering Section continued

### Track Capacity

Track capacity of all cam followers and cam yoke roller bearings is the load which a steel track of a given tensile strength will withstand without plastic deformation or brinelling of the track surface. The following tables list track capacities and track capacity factors for steel tracks, as applied to all cam follower and cam yoke roller bearings except crowned O.D. versions. For the crowned O.D. versions, multiply by 0.8 to obtain the track capacity ratings.

To obtain track capacities for a track hardness other than 40 Rockwell “C” scale (180,000 psi or 1242 Mpa tensile strength), multiply the track capacity by the track capacity factor in Table 1. Regardless of the resulting track capacity, dynamic load should not exceed 50% of the dynamic rating as a track roller and static load should not exceed the static rating as a track roller for that bearing.

**Table 1 - Track Capacity Factor**

Track Tensile Strength, psi	Track Tensile Strength, MPa	Track Hardness Rockwell “C”	Track Capacity Factor
60,000		69	0.111
80,000		85	0.198
100,000		95	0.309
120,000	828	26	0.445
140,000	966	32	0.607
160,000	1104	36	0.792
180,000	1242	40	1.000
200,000	1380	44	1.237
220,000	1518	47	1.495
240,000	1656	50	1.775
260,000	1794	53	2.090
280,000	1932	56	2.420
300,000	2070	58	2.780

**Table 2 - Track Capacity, Inch Series Bearings**

Basic Bearing Number	Track Capacity Lbs.	Basic Bearing Number	Track Capacity Lbs.
1/2-N	485	1 7/8	5,415
1/2	530	2	7,350
5/9	595	2 1/4	8,260
5/8-N	725	2 1/2	11,100
5/8	785	2 3/4	12,250
2/3	865	3	15,050
3/4	1,085	3 1/4	16,300
7/8	1,260	3 1/2	20,200
1	1,835	4	26,200
1 1/8	2,060	5	38,600
1 1/4	2,660	6	55,600
1 3/8	2,920	7	75,600
1 1/2	3,760	8	94,000
1 5/8	4,065	9	118,000
1 3/4	5,060	10	145,000

**Table 3 - Track Capacity, Metric Series Bearings**

Basic Bearing Number	Track Capacity Newtons	Basic Bearing Number	Track Capacity Newtons
M CFR-13-X	2390	M CFR-52-X	24000
M CFR-16-X	3675	M CYRR-25-X	24000
M CYRR-5-X	3675	M CFD-52-X	24000
M CFR-19-X	4360	M CYRD-25-X	24000
M CYRR-16	4360	M CFR-62-X	35500
M CFR-22-X	5340	M CYRR-30-X	34250
M CYRR-8-X	6875	M CFD-62-X	35500
M CFR-26-X	6310	M CYRD-30-X	34250
M CFR-30-X	7940	M CFR-72-X	39750
M CYRR-10-X	7940	M CYRR-35-X	38125
M CFR-32-X	8475	M CFD-72-X	39750
M CYRR-12-X	8475	M CYRD-35-X	38125
M CFR-35-X	12300	M CFR-80-X	54750
M CYRR-15-X	12300	M CYRR-40-X	45875
M CFD-35-X	12300	M CFD-80-X	54750
M CYRD-15-X	12300	M CYRD-40-X	45875
M CFR-40-X	15000	M CFR-85-X	58000
M CYRR-17-X	15000	M CYRR-45-X	48750
M CFD-40-X	15000	M CYRD-45-X	48750
M CYRD-17-X	15000	M CFR-90-X	61500
M CFR-47-X	21750	M CYRR-50-X	51625
M CYRR-20-X	21750	M CFD-90-X	61500
M CFD-47-X	21750	M CYRD-50-X	51625
M CYRD-20-X	21750		



# Cam Follower Engineering Section continued

## Cam Design

Most cam applications are similar in many respects to the track or support roller applications; however, usually bearing speeds are higher due to the multiplication of cam revolutions per minute by the ratio of the cam O.D. to the cam follower O.D. For cam applications, oil lubrication is preferred due to the tendency towards higher speeds noted above. Where such lubrication methods are not possible, frequent replacement of grease should be followed.

In the application of box or drum cams, it is possible to obtain differential rotation of the cam follower outer race as well as associated load reversals. Unless proper cam hardness and materials are employed as well as ample lubrication, excessive cam or cam follower wear may result. In box cams of this nature, the cam rise and cam fall should be watched closely, since the load reversal encountered can cause shock loads in excess of the capacity of the stud or the bearing.

The above precaution would also apply to ordinary circular cams, and instantaneous loads due to rapid cam rise should be carefully calculated and kept below the maximum recommended load or static capacity as listed for the bearing.

In ordinary cam design it is possible to employ the most efficient materials for best resistance to fatigue and brinelling. Attainment of high track surface hardnesses associated with good wear resistance are quite feasible. The same general precautions with regard to tensile strength versus hardness, as listed under track design above, should be followed for cam design; and applications involving high marginal bearing or cam loading should be referred to Application Engineering for review.

## Cam Follower and Track Roller Bearing Lubrication

Standard series cam followers and track rollers as listed are factory filled with an NLGI 2 grease suitable for operating temperatures of -20°F to +250°F. Consult Application Engineering regarding grease compatibility issues.

Series	Type
CF, CFH, CYR, CFD, CYRD, MCF, MCYR, MCFD, MCYRD,	Lithium Soap
SDCF, SDMCF	Lithium Complex Soap
PCF, PCYR, FCF, FCYR, VCF, VCYR (Ball Bearing)	Lithium Soap
PCF, PCYR, FCF, FCYR, VCF, VCYR (Tapered Roller Bearing)	Polyurea
BCF, BCYR	Not grease lubricated, coated with preservative oil.
CF-CR, CYR-CR	Aluminum Complex Soap USDA H-1 Authorized*

\* Authorized by USDA for use in federally inspected meat and poultry plants. USDA H-1 authorized lubricants may be used on equipment as a lubricant or anti-rust film in locations in which there is exposure of the lubricated part to the edible product.

Frequency of lubrication depends primarily upon the speed of rotation of the bearing, the type of lubrication employed and the amount of contamination present in the application. It is possible to achieve extended operating life without lubrication where speeds are low and contamination is not excessive. This is primarily true in track support applications where bearing rotation is intermittent.

For continuously rotating applications, it is necessary to either provide continuous oil lubrication or else frequent grease lubrication, depending upon the severity of service. Automatic lubrication devices are ideal for intermittent lubrication, since accurate metering of grease and consistent relubrication is maintained through the use of these devices. In applications involving paper dust and other similar abrasive contaminants, relubrication must be resorted to at more frequent intervals and Application Engineering should be consulted for these critical applications. In LUBRI-DISC® sealed cam followers and track rollers, small vents or reliefs are provided in each seal to enable relubrication of the bearing. To avoid loss of seal efficiency, these seal vents are kept as small as possible, and for this reason the rate of relubrication should be kept at lower levels to avoid seal displacement.

## Cam Follower Engineering Section continued

### Reduced Maintenance Cam Followers and Track Rollers

Series CFD, CYRD, SDCF, SDMCF, PCF, FCF, VCF cam followers and track rollers are designed for use without relubrication and are not provided as standard with provisions for relubrication. These types of bearings may be limited by the life of the original grease fill and the ability of the seals to protect the bearing from contamination.

### Lubrication of Stud-Type Cam Followers and Track Rollers

Series CF, CFH, CF-CR, MCF and MCFD cam followers and track rollers with integral studs are supplied with potential for 3 alternate means of lubrication; namely, through either end of the stud with an appropriate grease fitting or through the radial hole in the stem of the stud.

- The four smallest sizes in inch series CF, CFH, CF-CR (1/2, 9/16, 5/8 and 11/16) and the three smallest sizes in metric series MCF (13, 16 and 19) are an exception to the above information, since they contain neither the radial oil hole in the stem nor the axial hole at the threaded end of the stud. Therefore, these bearings may only be lubricated from the flange end of the stud in the screwdriver slot type only.
- The radial oil hole is not present in metric series MCF sizes through 26 mm OD.
- Bearings utilizing the hex hole feature, unless noted otherwise on the dimension tables, do not have the axial lubrication hole present at that end.

Since in most cam followers two axial lubrication holes are provided, it is necessary to plug one or both of the holes, depending upon the type of relubrication means employed. For this purpose, oil hole plugs are provided in the bearing wrapping and may be press fitted in the reamed lubrication fitting hole. They are designed to withstand normal relubrication pressures. If the stem radial oil hole is present but not used for relubrication, it should be covered by the housing; therefore, no plug is supplied for this hole.

### Grease Lubrication Fittings

Series CF, CFH, CF-CR

Basic Bearing No. Bearing Size	Drive Fitting Size	Ref. Alemite No.	Fitting Included
1/2 to 11/16 incl.	1/8"	3019	No
3/4 to 2 3/4 incl.	3/16"	1728-B	No
3 to 4 incl.	1/4"	1743-B	Yes*
5 to 10 incl.	1/4" NPT	1627-B	No
* For hex hole option only.			

Series MCF, MCFD

Basic Bearing No. Bearing Size	Drive Fitting Size	Fitting Included mm
13	3.1	Yes
16 to 26 incl.	4	Yes
30 to 40 incl.	6	Yes
47 to 90 incl.	8	Yes

### Lubrication of Yoke-Type Cam Followers and Track Rollers

The relubrication of yoke-type cam follower and track roller bearings is straight forward and is accomplished by means of a radial oil hole and annular lubrication groove found on the inner race of the bearing series. The mounting pin for this bearing series must be drilled axially and radially to properly line up with the groove and hole of the CYR bearing inner race to effect proper lubrication.

# Cam Follower Engineering Section continued

## Mounting Details - Stud Type Cam Followers and Track Rollers

### Series CF, CFH, BCF, CF-CR, CFD, MCF, MCFD

Proper mounting of stud type cam follower and track roller bearings require a close fit between the bearing stud and the housing hole. The endplate must be backed up by the housing member face. Likewise the face of the housing adjacent to the bearing endplate face should be square to the housing bore. The following are some general guidelines and details to bear in mind when installing the above series' bearings.

#### 1. Inspect housing.

- Clean, remove burrs and sharp edges.
- Check housing bore diameter. The stud diameter should have a tight fit in the housing bore. Refer to the recommended housing bore diameters given in the dimensional tables.

#### 2. Press stud into housing.

- For best bearing performance, bearing should be mounted with raceway radial lubrication hole in the unloaded portion of the raceway. Raceway radial hole is oriented in line with stem radial hole.
- Direct pressure against solid end of stud, not against the flanged portion.
- Do not apply pressure against outer ring face.
- Use arbor press whenever possible.
- Do not hammer on bearing faces.

#### 3. Install nut and lock washer.

- Follow recommended clamping torque on dimensional table. Do not over tighten, otherwise undue stress may be set up in stud. Overtightening nut can also cause stretching of the stud diameter with consequent loosening of the stud in the housing member.
- A screwdriver slot is provided at the flanged end of the stud for the purpose of preventing the stud from turning when the nut is tightened. The bottom of the screwdriver slot is rounded and in some cases it may be necessary to use a special screwdriver having a rounded edge to hold the stud securely.
- An optional hexagonal hole is provided in the stud face on selected sizes for use with applications requiring greater than average thread torque or for ease of installation. In this modification, the ability to relubricate through the flange end of the stud, unless otherwise noted in the dimension tables, is eliminated.





## Cam Follower Engineering Section continued

### Blind Hole Mounting

Sometimes a stud type follower must be mounted where a nut and lock-washer cannot be used on the threaded portion. In such blind hole mountings, special care must be given to the fit-up of the stem in the housing.

- The drilling diameter used for tapping will generally result in a loose fit between the stud and housing hole. This can lead to premature fatigue fracture of the stud in applications with varying or reverse radial load. Press fitting the stud into a reamed hole without tapped threads would be better for these applications. The non-hardened stud can be retained by drilling and pinning, or by using a set screw to bear against the stud.
- Certain applications require blind hole mounting into tapped threads. The hex hole option should be used in these cases so that adequate torque can be applied to provide good endplate support.

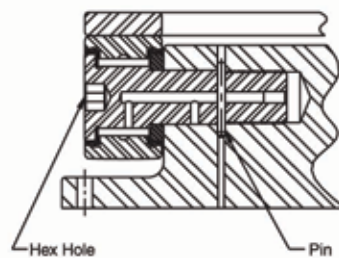

Blind Hole Mounting

### Eccentric Bushing Mounting

**Series CFE, BCFE, CFE-CR, SDCFE, SDMCFE, CFDE, MCFE, MCFDE, PCFE, FCFE, VCFE**

In addition to the mounting details listed above, the following should be considered for proper mounting of stud type followers with the eccentric bushing option.

- The eccentric bushing diameter should have a .001" to .005" loose fit in the housing bore. Refer to dimensional table for specific housing bore diameter.

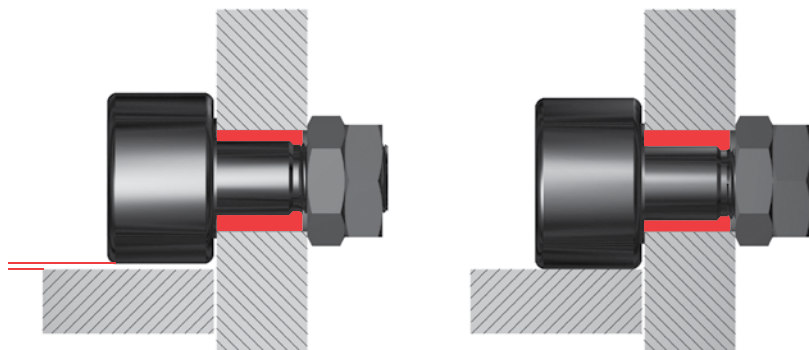

## Cam Follower Engineering Section continued

- For proper end-wise clamping, housing width must be .010" wider than bushing length.
- Lock-nut or lock washer and nut is sufficient to hold the bearing at the desired position for most applications.
- Where a more positive means of holding a given position is required, the bushing and stem can be drilled for pinning. Bushing and exposed stem area is unhardened steel.
- Hex hole option allows more positive grip for adjustment and locking.

### Series PCF, FCF, VCF, SDCF, SDMCF

These series cam followers and track rollers do not have an exposed stud face at the roller end. That face is enclosed by a metal plug assembled into the outer ring face. A loose stud fit in the housing is recommended so that minimal pressure is required to drive stud into the housing bore.

- Recommended housing bore fit for these series is .0005" to .0025" loose. Refer to dimensional table for specific housing bore diameter.
- A hex hole is provided at the threaded end of the stud for the purpose of holding the stud from turning when the nut is tightened.
- These series can not be tightened into a blind drilled and tapped hole.

### Mounting Details - Yoke Type Cam Followers and Track Rollers

#### Series CYR, CYR-CR, CYRD, MCYR, MCYRD

Endplate support is critical when mounting yoke-type series cam followers and track rollers. If the endplates are not properly backed up, they can be displaced from the inner ring. The preferred mounting method is to provide complete axial clamping of the endplates.

If the endplates can not be clamped end-wise, it is essential to have a close fit axially in the yoke in which the bearing is mounted to prevent the bearing endplates displacing axially.

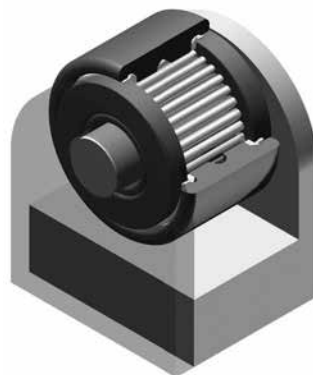

## Cam Follower Engineering Section continued

The following are some general guidelines and details when installing yoke type followers.

- 1. Inspect housing.**
  - Clean, remove burrs and sharp edges.
- 2. Check shaft diameter size.**
  - Follow recommended shaft fits per table below. Refer to dimensional table for specific shaft diameter and tolerance.
- 3. Press shaft through bearing within yoke housing.**
  - For best bearing performance, mount follower with lubrication hole in the unloaded portion of the raceway.
  - Apply pressure towards center or below on endplate face if pressing bearing onto shaft.
  - Do not apply pressure against outer ring face.
  - Use abor press whenever possible.
  - Do not hammer on bearing faces.

### Shaft Fit Selection - Inch Series CYR, CYR-CR, CYRD

Load	End-Wise Clamped	Fit	Shaft Condition
Light	Yes	Push	Not Hardened
Medium	Yes	Push	Hardened
Heavy	Yes	Drive or Press	Hardened
Light	No	Press	Not Hardened
Medium	No	Press	Hardened
Heavy	No	Press	Hardened

### Shaft Fit Selection - Metric Series MCYR, MCYRD

Load	End-Wise Clamped	Fit	Shaft Condition
Light	Yes	g6	Not Hardened
Medium	Yes	g6	Hardened
Heavy	Yes	h6 or j6	Hardened
Light	No	j6	Not Hardened
Medium	No	j6	Hardened
Heavy	No	j6	Hardened

### Special Modified Cam Follower and Track Roller Bearings

McGill offers certain options for the CF, CFH and MCF series cam follower and track roller bearings with low minimum order quantity and short order lead time. Contact customer service for price and delivery information, 1-800-626-2120.

### Threaded Axial Lubrication Holes

Standard reamed axial hole is tapped to accommodate threaded lubrication fitting. This option is popular when using automatic lubrication systems.

# Cam Follower Engineering Section continued

## Specifications - Inch Series

Bearing OD Size	Thread Size
1/2 thru 1 1/16	Not Available
3/4 thru 1 3/8	1/4-28 UNF
1 1/2 thru 4	1/8 NPT

## Specifications - Metric Series

Bearing OD Size	Thread Size
13	Not Available
16 thru 26	M6 X 0.75
35 thru 90	1/8 NPT

## Axial Lubrication Holes Plugged

Options include threaded end, flange end or both ends of stud. Plugs are normally supplied loose in box. If the bearing is not to be lubricated in service, plugging the holes helps prevent entry of contamination. Bearings supplied with plugs installed saves user's time and provides a bearing ready to install.

## Hex Hole or Screwdriver Slot at Threaded End of Stud

These options are typically selected when roller end of stud is not accessible at installation.

## Annular Lubrication Groove at Stem Radial Hole

This option helps entry of lubricant through stud radial hole so that alignment of stem and housing lubrication holes is not critical

## Hex Wrench Sizes

Basic Bearing No.	Hex Wrench Sizes	Basic Bearing No.	Hex Wrench Sizes
1/2	1/8	1 7/8	5/16
9/16	1/8	2	7/16
5/8	1/8	2 1/4	7/16
11/16	1/8	2 1/2	1/2
3/4	3/16	2 3/4	1/2
7/8	3/16	3	3/4
1	1/4	3 1/4	3/4
1 1/8	1/4	3 1/2	3/4
1 1/4	1/4	4	3/4
1 3/8	1/4	5	7/8
1 1/2	5/16	6	1
1 5/8	5/16	7, 8, 9, 10	1 1/4
1 3/4	5/16	-	-